



aerospace
climate control
electromechanical
filtration
fluid & gas handling
hydraulics
pneumatics
process control
sealing & shielding



Mining Hoses, Fittings and Equipment



ENGINEERING YOUR SUCCESS.

Detailed table of Contents

Introduction

2 – 43

MINING HOSE

Mining Hose

B-1 – B-14

Fittings

Parkrimp No-Skive

43 Series

Ca-1 – Ca-12

48 Series

Cb-1 – Cb-29

70 Series

Cc-1 – Cc-14

73 Series

Cd-1 – Cd-13

77 Series

Ce-1 – Ce-24

ParLock

V4 / V6 Series

Cf-1 – Cf-21

Adaptors

Steck0®

D-1 – D-16

SuperSteck0®

D-17 – D-23

Ball Valves

Steck0®

E-1 – E-6

SuperSteck0®

E-7 – E-8

Accessories

Hose Protection

F-1 – F-8

Hose Whip Restraint

F-9

Flange

F-10 – F-11

O-Rings

F-12 – F-13

Machines

Crimping

Parkrimp System

G-1 – G4

Adjustable Crimper

G-5 – G-7

Hose Cutting

G-8 – G-11

Skiving

G-12 – G-13

Marking

G-14

Cleaning

G-15

Testing

G-17

SOLVING THE WORLD'S GREATEST ENGINEERING CHALLENGES.

Our focus on solving some of the world's greatest engineering challenges sparks our passion for innovation and secures our future growth.

The development of more efficient energy sources; the desire to produce and distribute clean water; new drug discovery and medical advances; the building of infrastructure and transportation to support a growing population; the safe cultivation, transportation and preservation of food sources; emerging developments in defense; and the protection of our environment – all of these challenges drive Parker people forward, seeking new ways to innovate, combine technologies, collaborate, develop systems and partner with our customers to solve problems.

ENGINEERING YOUR SUCCESS.

If you view the world as we do, through the lens of our broad range of motion and control technologies, you can see a vast number of engineering challenges that are yet to be solved and can make a meaningful difference in the lives of people everywhere.

Our engineering expertise spans the core motion and control technologies – electromechanical, hydraulic and pneumatic – as well as a full complement of fluid control systems; software and electronic controls; filtration systems; and refrigeration, instrumentation and sealing technologies.

Our focus is on our customers. By improving their productivity and profitability we create a cleaner, more efficient future for everyone.



MINING

INNOVATION AND COMPLIANCE

Parker Hannifin believes that the safety of people and property is of paramount importance. To that end, Parker designs, engineers and manufactures its products to the highest standards. Wherever mandated, Parker complies with all industry standards and regulations. Additionally Parker products are both lab and field tested to ensure product integrity and safety.

Industry Recognized

Our mining program is approved by well known international classification bodies.

These organizations establish standards for safety and performance that given the safe design and construction of mining equipment. Owners, purchasers and miners are assured that approved parts possess the structural and mechanical capability for safe performance.



British organisation for safety in the mining industry



US organisation for safety in the mining industry



MDG41 Mechanical Design Guide-line for Fluid power system safety and Mines by NSW Department



Mining Products Safety Approval and Certification Center (MA Center approves and certifies safety of certain mining products.



The OBAC (Ośrodek Badań Atestacji i Certyfikacji - Institute for Research and Certification Ltd). is a private certification body authorised to test and certify equipment and components for use in Polish underground mines.

ENGINEERED SOLUTIONS

focusing safety, downtime and throughput



Photo: Atlas Copco

Safety, reducing downtime and increasing your throughput are the most important keys to your success. Corresponding to your priorities, we at Parker Hannifin can offer you a wide array of solutions and services aligning with your needs – whether you're working in a drag line or high wall surface mine, conventional underground or long wall mine.

Let Parker become part of your design team. Whether you need to develop new products, redesign existing applications, or design completely new systems, Parker offers unparalleled engineering expertise. These relationships are cultivated by listening closely to our customers and repeatedly providing them with value measured in real dollars: saved time, reduced waste,

gained efficiency, expanded output and increased profitability. The following pages provide a complete overview of the hydraulic hose and fittings solutions and services that Parker provides the mining industry.



SAFETY & RELIABILITY

APPLICATION AREAS

of mining hoses, fittings, adaptors and accessories

Parker's mining hoses, fittings and adaptors provide a complete, reliable hydraulic package to connect and support the mining equipment. All Parker mining hose products combine international approvals with total system integrity and long service life in hostile conditions. Special coatings and carefully selected materials ensure reliability in corrosive environments.



Longwall

When it comes to building the safest, most complete mining packages at the lowest cost, no company can beat Parker. Our mining product solutions featuring System SteckO® connections reliably provide for cutters as well as roof-support cylinders, cutter-feed systems, sump functions and conveyers. Parker provides robust products and matched systems for your most arduous applications.

SteckO® product typically utilized to Longwall roof supports, Monorail, Shearer (drum cutter) & Boom Stage Loader and Main Gate.

Product	Feature	Major Benefits
COALMASTER Hose	Abrasion resistant MSHA cover	Long service life; Compact hose routing
Parker Compact Spiral™ Hose	1/2 bend radius, 1,000,000 cycle life	Increased routing flexibility and longer service life
SteckO® Swivel	Robust 360° rotation	Extended hose life and reduced cost by elimination of hose twist
System SteckO® + 'D' section staple	Staple style connection; Ductile +300,000 cycle life, fully traceable	Quick wrenchless assembly and disassembly; Safety & installed life
Air Water hose	MSHA & FRAS approved	Long service life

Staple Pressure Rating Table

SteckO®			SteckO® with 'D' Staple				Super SteckO®				SUPER SteckO® with 'D' Staple			
DIN	Dash Size	Pressure Rating (bar)	DIN	Dash Size	Pressure Rating (bar)	Impulse Cycles	DIN	Dash Size	Pressure Rating (bar)	Impulse Cycles	DIN	Dash Size	Pressure Rating (bar)	Impulse Cycles
6	4	450	6	4	450		6				6			
10	6	400	10	6	420	200	10				10			
12	8	362	12	8	420	250	12	8	518		12	8	518	
20	12	280	20	12	350	1,000,000	20	12	420		20	12	420	
25	16	280	25	16	350		25	16	380		25	16	420	1,000,000
32	20	210	32	20	350		32	20	350	1,000,000	32	20	420	1,000,000
40	24	210	40	24	350		40	24	350	750	40	24	420	1,000,000
50	32	170	50	32	210		50	32	350	500	50	32	420	1,000,000
65			65				65				65			



Continuous Miners

Parker offers innovative mining solutions to meet the growing demand for compact machines. Continuous miners historically used for a/ Bord & Pillar extraction (thin & thick seams). Typically modern continuous miners are being used for 'development' of longwall set-up. Continuous miners also used in Potash and salt extraction (underground) - typically Bord & pillar extraction.

Parker hoses with tight bending radii and the dedicated fittings are designed to meet the industry's highest standards.



Product	Feature	Major Benefits
COALMASTER Hose	Abrasion resistant MSHA cover	Extended service life; Eliminates the need for spiral wraps/guards
Parker Compact Spiral™ Hose	1/2 bend radius, 1,000,000 cycle life	Increased routing flexibility + installed life
Threaded Adapters	Forged shapes, robust port connection	Greater strength and reliability

High degree of automation (safety & productivity oriented)
 – Parker opportunities in Intrinsicly safe valves, pumps, actuators, filters & cartridge / manifolds

Tunnel Boring

Parker's mining solutions offer the most complete, highest quality, most leak-free hydraulic and fluid connector packages for Tunnel Boring, where high impulse vibrations are commonplace. Parker's types of abrasion resistant hoses fit any though application and offer bend radii to meet Tunnel Boring's tight routing requirements. Durable Parker products mean low warranty expenses for hydraulic systems.



Product	Feature	Major Benefits
Parker Compact Spiral™ Hose	Abrasion resistant MSHA cover; 1/2 bend radius, 1,000,000 cycle life	Increased routing flexibility + installed life
Threaded Adapters	Forged shapes, robust port connection	Greater strength and reliability

High degree of automation (safety & productivity oriented)
 – Parker opportunities in Intrinsicly safe valves, pumps, actuators, filters & cartridge / manifolds



Rock Driller (Underground)

Parker's mining solutions offer the most complete, highest quality, most leak-free hydraulic and fluid connector packages for rock drilling, where high impulse vibrations are commonplace. Parker's types of abrasion resistant hoses fit any though application and offer bend radii to meet rock drilling's tight routing requirements. Durable Parker products mean low warranty expenses for hydraulic systems.

Product	Feature	Major Benefits
Parker Compact Spiral™ Hose	Abrasion resistant; 1/2 bend radius, 1,000,000 cycle life	Increased routing flexibility + installed life
Threaded Adpaters	Forged shapes, robust port connection	Greater strength and reliability

High degree of automation (safety & productivity oriented)

– Parker opportunities in Intrinsically safe valves, pumps, actuators, filters & cartridge / manifolds

Load Haul Dump – LHD's

Parker's mining solutions offer the most complete, highest quality, most leak-free hydraulic and fluid connector packages for LHD's, where high impulse vibrations are commonplace. Parker's types of abrasion resistant hoses fit any though application and offer bend radii to meet LHD tight routing requirements. Durable Parker products mean low warranty expenses for hydraulic systems.



Product	Feature	Major Benefits
Parker Compact Spiral™ Hose	Abrasion resistant MSHA cover; 1/2 bend radius, 1,000,000 cycle life	Increased routing flexibility + installed life
Threaded Adpaters	Forged shapes, robust port connection	Greater strength and reliability

High degree of automation (safety & productivity oriented)

– Parker opportunities in Intrinsically safe valves, pumps, actuators, filters & cartridge / manifolds

Surface Mining

Machinery used in surface mining varies widely from the equipment used in underground mining. The types of machinery used in strip, contour, open pit and mountain top removal mining are similar to those used on typical construction sites around the world. Parker solutions include all to keep surface miners working around the clock, eliminating downtime and delivering the lowest total cost of ownership to customers. Wherever the mine is, Parker is there with the people, products and services needed to address your concerns and keep you up and running.



Product	Feature	Major Benefits
Parker Compact Spiral™ Hose	Abrasion resistant MSHA cover; 1/2 bend radius, 1,000,000 cycle life	Increased routing flexibility + installed life
Threaded Adapters	Forged shapes, robust port connection	Greater strength and reliability
Hydraulic Fittings	Monoblok construction	Extended hose life in articulating joints

High degree of automation (safety & productivity oriented)

– Parker opportunities in Intrinsically safe valves, pumps, actuators, filters & cartridge / manifolds



Rock Driller (Surface)

Parker's mining solutions offer the most complete, highest quality, most leak-free hydraulic and fluid connector packages for exploration & blast drilling, where high impulse vibrations are commonplace. Parker's types of abrasion resistant hoses fit any tough application and offer bend radii to meet rock drilling's tight routing requirements. Durable Parker products mean low warranty expenses for hydraulic systems.

Product	Feature	Major Benefits
Parker Hose	Abrasion resistant tight bend radius	Extended service life; Eliminates the need for spiral wraps/guards, compact installation
Threaded Adapters	Forged shapes, robust port connection	Greater strength and reliability
Bull hose / Air Water hose	MSHA & FRAS approved	Long service life

High degree of automation (safety & productivity oriented)

– Parker opportunities in Intrinsically safe valves, pumps, actuators, filters & cartridge / manifolds

MINING HOSE AND FITTINGS

Systems you can trust

COALMASTER® Hose & SteckO® Fittings and Adaptors

Parker COALMASTER® and System SteckO® mining products provide complete, reliable hydraulic packages to connect and support underground mining equipment. System SteckO® adaptors are compatible with a range of COALMASTER mining hoses, ball valves and forged adaptors and manifolds. All COALMASTER products combine international approvals with total system integrity and long service life in hostile conditions. Special platings, coatings and carefully selected materials ensure reliability in corrosive environments.

Coalmaster mining hose with 2- wire braid, 4- and 6- wire spiral constructions is the most comprehensive range available to the mining industry. All hoses have been specially designed to meet requirements of a hazardous and harsh environment. Every hose is built and thoroughly tested to ensure they meet or exceed recognized international mining standards. Along with the well known SteckO® fittings and adaptors serving all your underground mining requirements.

The range includes:

- Coalmaster Hoses from 1/4" to 3" I. D., MSHA approved (complete mining hose range up to 3")
- Pressures up to 45.0 MPa
- Temperatures from -40 °C to +100 °C
- Fittings in steel and stainless steel

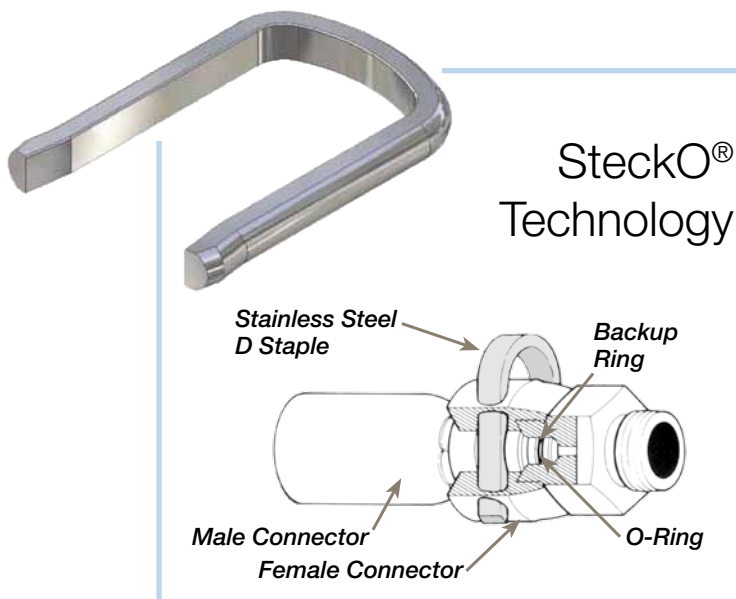
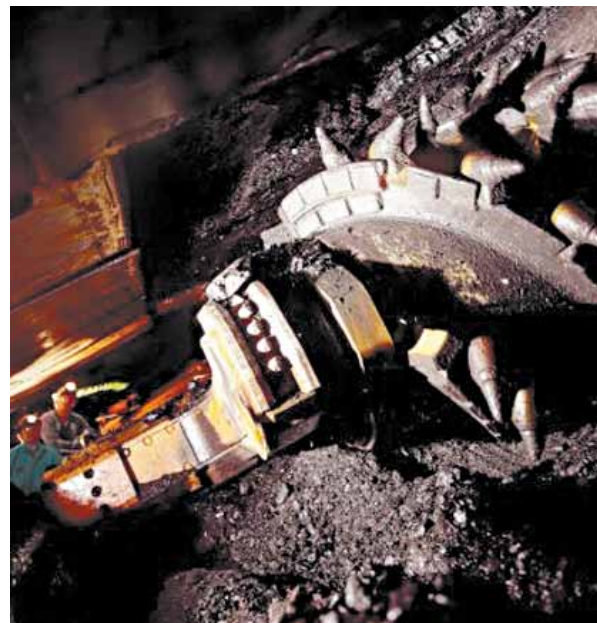

The original SteckO® staple connection system was introduced into the mining industry. The unique design enables the connection of hydraulic components, replacing threads or flange type fittings. Further development of SteckO® into the Super SteckO® range enabled higher working pressures and higher flow rates capabilities. The simple to install SteckO® system allows male and female end terminations to be held together by a U-shaped staple. The male connection part has a groove and a seal. The SteckO® male connection part is then located into the female connection part and is secured by staple in the male groove. The result is a safe connection which is suitable for heavy duty applications and can be (de)mounted easy and quick. The SteckO® system reduces the torsion in the hose to a minimum.

Parkrimp® and ParLock Hose and Fittings

Largest range of MSHA approved 2-wire braided hoses in standard and compact design, as well as 4-and 6 spiral hose with unique crimping technologies, such as No-Skive, Compact Spiral™ and ParLock. Combined with a complete fitting offer along with all international recognized connections in steel and stainless steel.

Endless combinations of customised hose fittings like jump sizes, specific end configurations, specific drop lengths, fittings-tube combinations, customised prototypes and any batch size upwards from a single piece can be realized.

The range includes:

- Hoses from 1/4" to 3" I. D., MSHA approved
- Pressures up to 42.0 MPa
- Temperatures from -40 °C to +125 °C
- Fittings in Cr6 free steel plating, stainless steel and/or zinc nickel



Parkrimp *No-Skive*

The easy to operate crimp system from textile to 6 spiral high tensile steel wire

Parkrimp No-Skive hose and fittings the system for fast and leak-free assemblies

- For crimping
Parkrimp No-Skive fittings only
- No skiving tool needed
- No need to remove the cover
- Quick and easy:
no gauges to set on the machine
- Portable machines for field repair
- Meets EN safety regulations

Parkrimp No-Skive is synonymous with the best solution for assembling hydraulic and related hose and fittings from both the technical and the manufacturing points of view!

Throughout the progressive rubber and metal compression during the crimping process the reinforcement always remains intact. The meticulous design, testing and manufacturing processes of Parkrimp No-Skive hose and fittings, combined with the approved crimping diameters provide an excellent mechanical connection between the hose and the fitting. This absolutely leak-free connection gives long service life even with the highest pressures associated with 4- and 6-spiral hose assemblies.

The smartly designed and time-tested Parkrimp No-Skive assembling equipment combined with Parker's assembling know how allow the safest, most efficient and mistake-proof assembly process. The Parkrimp equipment allows cost and time savings to the assembler and guarantees a defect-free, reliable and durable final product to the end-user.

No-Skive

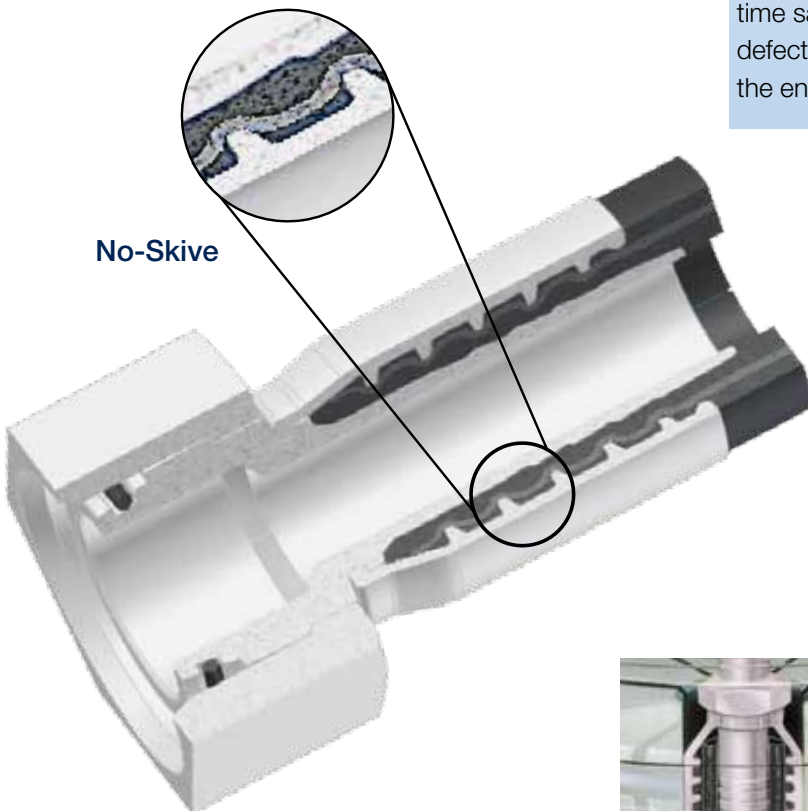

The perfect match

The complete system from one source. No-Skive hose, No-Skive fitting and crimping machine with world-wide guarantee and availability.



Parkalign

Parker's exclusive Parkalign positions the fitting in the dies perfectly every time.



Parker's colour-coded die sets

No loose parts to mismatch or misplace – die set segments linked together. Die sets provide 360° evenly applied crimping forces for an ideal crimp result.

ParLock

The system for extremely dynamic pressure applications

For manufacturing the ParLock hose assemblies Parker Hannifin offers

- Skiving machines for external and internal skiving
- Universal crimping machines with adjustable crimping diameter
- Detailed assembling instructions (see further in this catalogue)

For applications with extremely dynamic pressure profiles, pressure surges and peaks, as well as applications with intense vibrations and hose flexing (bending), especially when close to the fitting, a strong mechanical grip by the fitting onto the hose is paramount.

A popular method accepted by the market of achieving this mechanical grip in such applications is to use hose fittings that „lock“ the metal reinforcement of the hose directly between the metal shell and nipple – for which the rubber of the hose has to be removed both externally and up to a certain length also internally (a concept generally called „Interlock“).

As a response to the market requirement for an „Interlock“ hose fitting system, Parker has developed the Parlock program. This range consists of a specific range of hose, fittings and assembly equipment combined with Parker crimping know-how.

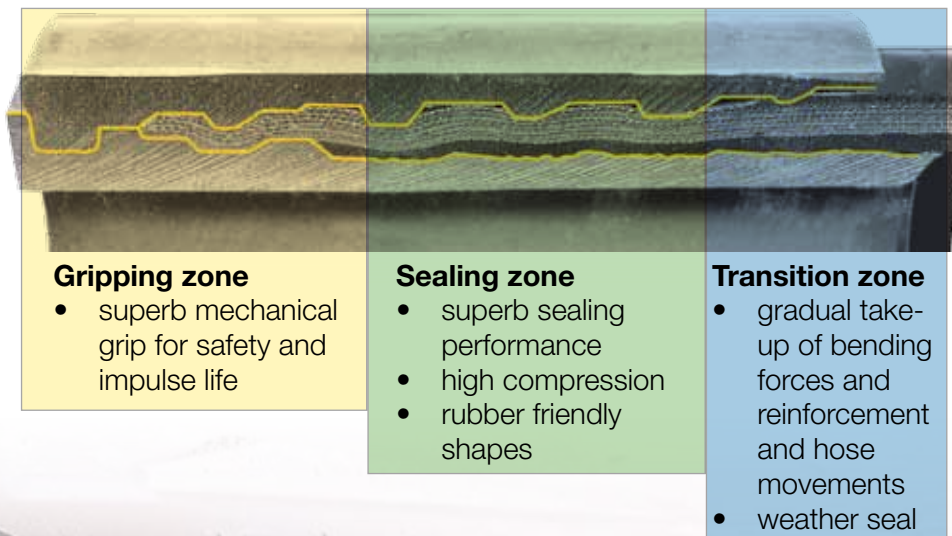

HOSE BASICS

Everything you need to know about Hydraulic Hose



It's all in the family

At Parker, we believe the best hose for your operation is the one that gets the job done right — no more, no less. That's why we offer you a comprehensive line of hoses, as well as all the options that go with it. Worried about price? We've got rubber hoses that are an exceptional value. Need hose that can take the heat? We've designed hoses for that. Looking for hose to handle the most demanding conditions? No problem. We have hoses made specifically for high temperatures, tight bending, abrasive environments, and more. Not sure what hose you need? Talk to our experts. They're trained to know, and they're happy to help.

Abrasion? We've got you covered

Our expanded line of abrasion-resistant hose offers you a world of protection, not to mention a choice of covers: Tough Cover (TC) for tough environments; and Coalmaster hoses for the really rough stuff. Our TC covered and Coalmaster hoses can simplify your assemblies by eliminating the need for any additional protective sleeving. From the superior flexibility and tighter bend radius of our wire-braided hoses... to the wide fluid compatibility and high pressure performance of our No-Skive spiral hoses... our expanded family of abrasion-resistant hoses gets the job done right, giving you the results you need in the construction, forestry, mining, injection molding, refuse and recycling, and energy industries.



Braided vs. spiral hose

Hydraulic hose can be referred to by construction style, of which there are two main types: braided and spiral. The majority of “low- pressure hoses” have a textile braided construction. They’re commonly used to transmit petroleum-based fluids, diesel fuel, hot lubricating oil, air, ethylene glycol anti-freeze, and water.

“Medium-pressure hoses” typically feature one- and two-wire braided construction. These hoses are frequently found on construction equipment, heavy-duty trucks, and fleet vehicle applications. In general, braided hose is selected for its flexibility.

At one time in the industry, two-wire braided hose was most commonly used in many applications. But the advent of larger, off-road specialty equipment drove the creation of spiral hose, which is very well suited for applications where extremely high impulse pressure is encountered.

Today, hydrostatic drives using four and six-wire spiral hoses

can be found on everything from lawn tractors to earth movers. Because today’s world demands faster, more powerful equipment requiring increased working pressures, Parker is responding with an expansive offering of spiral products.

Contact your local Parker distributor to see the full range of hose choices, and to discuss their various applications.

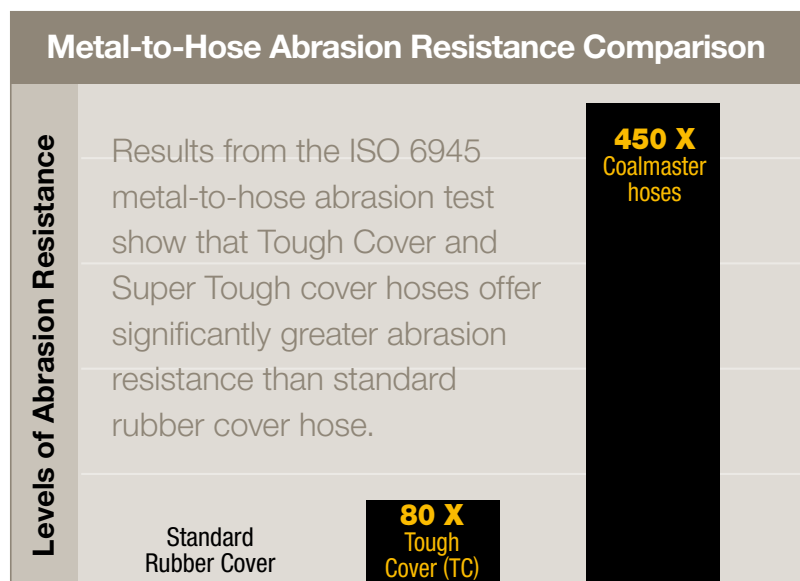

Compact Spiral™ Hose

The next evolution
in hydraulic hose

Unprecedented 35.0 and 42.0 MPa
hose performance in a compact design

Compared with conventional spiral hose, Parker's Compact Spiral™ 787TC/797TC hose offers measurably greater advantages in routing and installation, product size and weight, inventory savings and much more. A world first, this development is the most significant advance in hydraulic hose since the introduction of Parker's No-Skive™ technology more than 25 years ago.

Compact Spiral™ was developed in concurrence with the industry trend toward high-pressure hose manufactured to ISO specifications. Its many innovative and proprietary features set new standards in value and deliver hose characteristics deemed.

Most important by
OEM and aftermarket
customers.



up to size -32 (2")



Just one series of hose ends, Parker's 77 series, covers all sizes of both 787TC and 797TC Compact Spiral™ hoses, simplifying fitting selection and reducing hose-end inventory.

Looking for flexible hose that can be routed in tight spaces?

Parker has a full line of hoses designed for one-half SAE bend radius at full SAE pressure. These hoses plumb and bend tighter than other SAE 100R1, 100R2, 100R4, 100R12 and 100R13 type hoses, reducing hose length requirements by up to 47%. The tighter bend radius means fewer bent tube fittings, and longer life in applications where machinery movement causes hoses to bend sharply. It also means reduced inventory requirements for you.

- 1/2 the bend radius of SAE 100R13/SAE 100R15
- 1/3 less effort to bend
- Nearly 30 % smaller O.D.
- Tested to 2,000,000 cycles
- High abrasion resistance
- Constant pressure
- Simplified fitting selection with 77 series in Interlock No-Skive design
- 25 % less hose weight



Bend Radius

Compact Spiral™ hose has half the bend radius of its SAE counterpart and a significantly smaller bend radius than the corresponding size of a Parker conventional spiral hose.

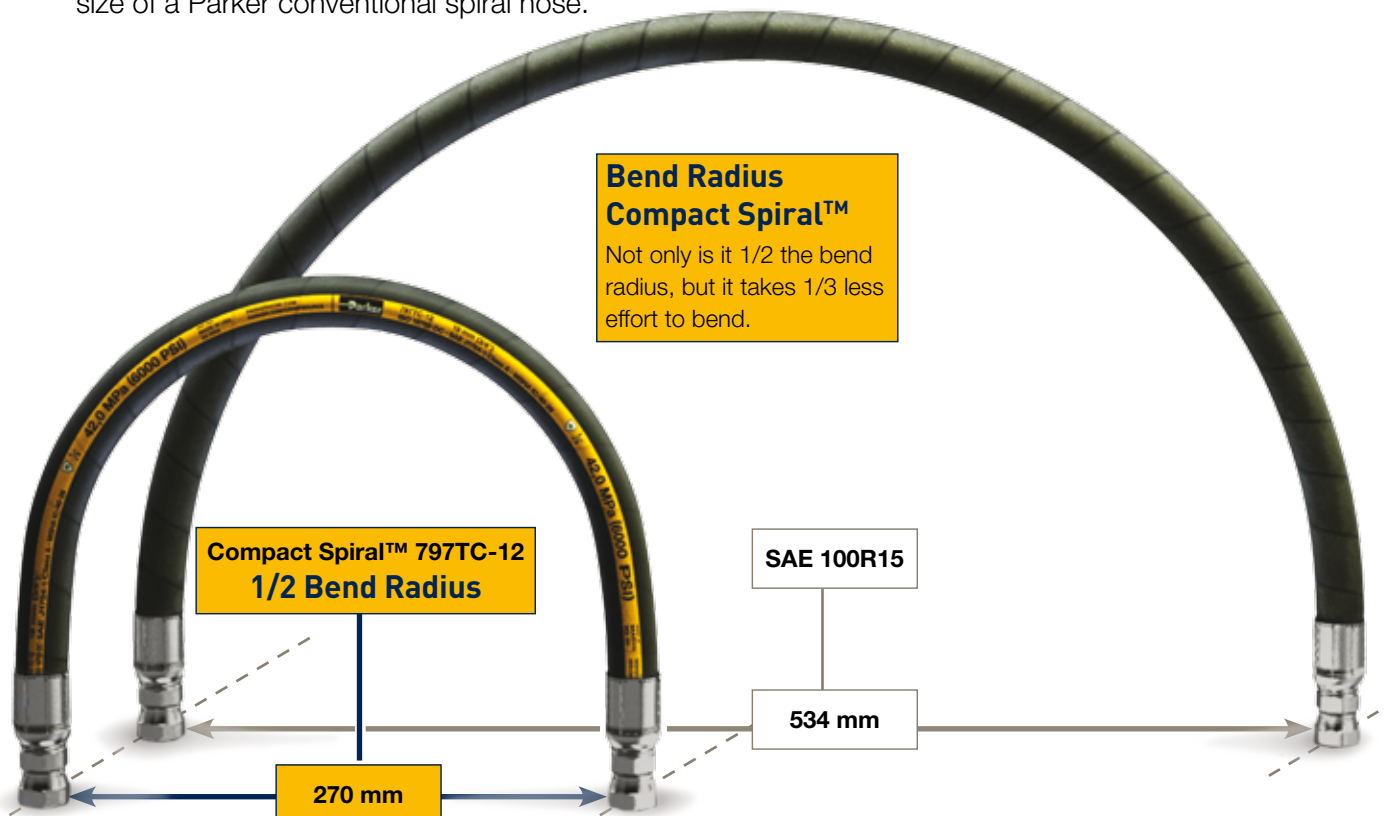

HOSE FITTINGS

The products of choice for custom and standard applications



Crimpable fittings

Parker Parkrimp assemblies consist of No-Skive hose and fittings, permanently joined by any one of our Parkrimp crimpers. The teeth in Parker's crimped fittings bite down to the hose wire for a metal-to-metal grip with maximum integrity. Our one-piece fittings can be combined with many No-Skive hose types to cover low-, medium- and high-pressure applications, as well as special application categories that can also be used with permanent crimped fittings.

We offer steel, brass, and stainless steel fittings from 3/16" to 3", with our steel fittings featuring a corrosion-resistant plating that exceeds SAE standards. Styles include o-ring face seal, flare, male pipe, metric designs and many more. All are compatible with the easy-to-use Parkrimp system of crimping machines.

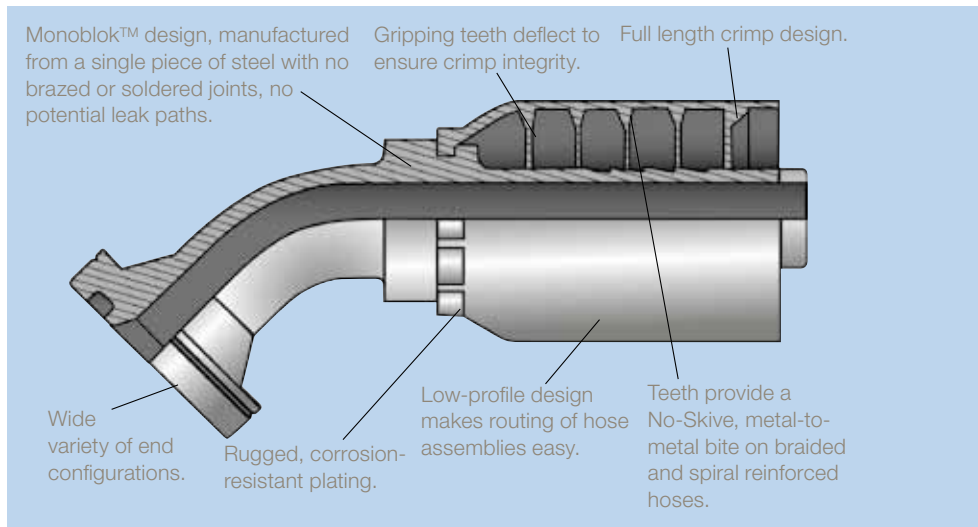

When combined with our No-Skive hose, Parker Parkrimp fittings provide factory-quality hose assemblies quickly and cost effectively.

Monoblok™ fittings

Monoblok™ fittings are manufactured from a single piece of steel. First introduced in ultra-high-pressure hydraulic ap-

plications, their lack of brazed or soldered joints provides the utmost in leak protection, eliminating any potential leak paths. Parker Monoblok fittings are available in a wide variety of end configurations and fitting series. These fittings also feature: No-Skive, bite-the-wire, full-length crimp, corrosion-resistant plating, weather seal, and a low-profile design.



Non Standard and Customised Hose Fittings

Short runs or special applications are met by Parker's Rapid Service Unit (RSU)

The Rapid Service Unit (RSU) can provide:

- Jump sizes
- Specific end configurations
- Specific drop lengths
- Fitting/tube combinations
- Customised prototypes
- Any batch size upwards from a single piece

Material options include steel, stainless steel, brass and special materials on request.



The Rapid Service Unit (RSU) is part of the Manufacturing Unit Fittings of Hose Products Division Europe and is a dedicated unit for the manufacture of customised and prototype hose fittings.

The unit is responsible for both checking the technical possibilities of the customer request from an engineering perspective as well as establishing the most economic production process. Because of close cooperation between Parker's Manufacturing Units and the Parker Sales Companies (PSC) the Rapid Service Unit (RSU) can live up to its name by reacting, quoting and supplying rapidly. After receiving the order, the RSU team will promptly and carefully process the order – from its receipt to the shipping of the fittings. For the production of such fittings, we have dedicated resources in a state-of-the-art manufacturing cell with CNC machinery and tools.

Hose Hint

How tight is tight enough? Differences in platings and other variables can affect the amount of torque required to ensure a proper connection. Always refer to this catalog or go to www.parkerhose.com for proper assembly procedures.

Hose End Type	Pressure	Seal Reliability	Vibration Resistance	Ease of Installation	Reusability	Temperature
Seal-Lok – O-Ring Face Seal	Excellent	Excellent	Very Good	Excellent	Excellent	Limited by Seal
37° Flare	Very Good	Good	Good	Good	Good	Excellent
Tapered – (NPT, NPTF, BSPT and Metric Taper)	Good*	Poor	Poor	Good	Poor	Excellent
Four-Bolt Flange	Excellent	Good	Excellent	Very Good	Excellent	Limited by Seal

*Rated 'Poor' for dynamic pressure systems.

Hose Hint

Never mix and match one manufacturer's fittings with hose from another manufacturer. Parker hose, fittings, and crimpers are designed to work together as a system. This ensures optimum product performance, reliability, and safety.

CRIMPERS

Make your own hose assemblies whenever YOU need them

Parkrimp® *No-Skive*

The system for fast and leak-free hose assemblies with No-Skive one-piece fittings

Hose fittings have an impact on the overall efficiency and safety of a hydraulic system. The No-Skive concept was launched by Parker Hannifin some 30 years ago but continuous development and the use of modern materials and production techniques have resulted in a state-of-the-art hose to fitting connection. Much easier handling and a high level of safety are available with No-Skive crimp fittings. Parker offers No-Skive fittings in one and two pieces as part of a package consisting of quality hose, No-Skive fittings, hose crimpers and tooling.

- No skiving tool needed
- No need to remove the cover
- Crimps one-piece fittings
- Parkalign positions the fittings in the dies perfectly every time
- Quick and easy: no gauges to set on the machine
- Portable machines for field repair
- Meets EN safety regulations



KarryKrimp® 2
85CE-061L



Parkrimp® 2
83CE-083U

Modular crimpers with Bench Power Unit for workshops

The modular design enables the customer to choose between the portability that Parker KarryKrimp crimpers have always offered, and the option to make these same crimpers bench mount units.

In addition to the portable versions, the sole crimping units can be used with the Bench Power Unit for workshop versions for faster cycle times, increased productivity and increased height for longer elbows or bent tube fittings.



KarryKrimp® 2 Bench Mount
85CE-061L + 85CE-1PE

Parker Crimpsource™

Crimpsource is the industry's most complete resource for crimper technical information. It contains all of the crimp specifications approved for Parker's hose:

- Crimp specs
- PDFs of technical manuals
- Parts lists
- Troubleshooting advice
- PDFs of crimper decals

ParLock Hose and Fittings

The high-performance skiving system with two-piece skive fittings



Certain customers and applications stipulate the usage of multispiral hose assemblies with external/internal skive-type fittings. With the ParLock hose and fitting range, Parker meets this demanding market requirement. Parker adjustable crimpers for two-piece fittings ensure precise, leak-free and tear-proof assembly of hose and fitting.

- A full range of multispiral hoses to ISO 3862 (4SP to R15)
- Field-tested, proven reliability
- Hose and fitting combinations giving performance that exceeds ISO/EN requirements
- Approved hose and fitting compatibility “one manufacturer, one source”
- High flex-impulse applications
- High vibration applications
- The ParLock design is approved by the German Accident Prevention & Insurance Association (Berufsgenossenschaft) conforming to EN 201 (approved for injection-moulding machine applications)



Hose skiving machine
TH2-13-3PH



Adjustable crimper
TH8E-530



Adjustable crimper
TH8E-380-BM



Adjustable crimper
TH8-800-BM

Crimpsource provides easy access to all the specifications necessary to correctly fabricate a factory quality hose assembly.

You can also print a simple-to-follow data specification sheet or crimper decal. Crimpsource is available at www.parker.com/crimpsource



HOW TO ORDER

Hose and Hose Fittings

To make ordering Parker products easier, we have itemized the order numbers on this page. This will be especially helpful when you order hose assemblies.

Hose

Example:

462TC-6

462TC-6 → Hose type

462**TC**-**6** → Hose inside diameter in size



Hose Fittings

Example:

1CA48-12-6

1CA48-12-6 → Fitting

1**CA**48-12-6 → End configuration

1CA**48**-12-6 → Parker Fitting series

1CA48-**12**-6 → Thread or tube size

1CA48-12-**6** → Hose / fitting size

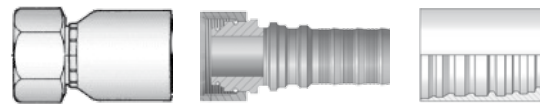

1 = Crimp fitting

K = ParLock Nipple

100 = Shell



End configuration nomenclature

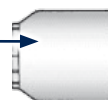

Fitting series

I.D. = size -6

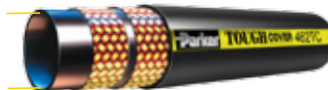

Material and specification:

Without suffix: steel, zinc plated, Cr6-free
 B: brass
 C: stainless steel
 K: without a plastic ring
 SM: metric hexagon dimension

The content of the hose crimping tables shows the standard part numbers. For the availability of non standard parts and materials please contact your local Parker service centre.

Hose Assemblies



Hose Assemblies

Example:

P462TCCACF12106-1000-0-SG900

P462TCCACF12106-1000-0-SG900

P**462TC**CACF12106-1000-0-SG900

P462TC**CACF**12106-1000-0-SG900

P462TCC**ACF**12106-1000-0-SG900

P462TCCACF**12**106-1000-0-SG900

P462TCCACF12**106**-1000-0-SG900

P462TCCACF1210**6**-1000-0-SG900

P462TCCACF12106-**1000**-0-SG900

P462TCCACF12106-1000-**0**-SG900

P462TCCACF12106-1000-0-**SG900**

- P** → Parkrimp No-Skive Fittings Series 26, 48
- D** → Parkrimp No-Skive Fittings Series 46
- F** → Parkrimp No-Skive Fittings Series 70, 71, 73, 76, 77
- E** → Parlock Skive Fittings Series VS
- V** → Parlock Skive Fittings Series V4
- S** → Parlock Skive Fittings Series V6

Hose type

Fitting 1 end configuration

Fitting 2 end configuration

Fitting 1 thread or tube size

Fitting 1 thread or tube size

Hose / fitting size

Hose assembly length in mm

Displacement angle is relevant when the hose assembly has bent fittings

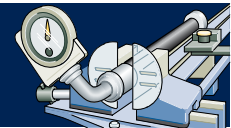

Accessory (e.g. spring guard 900 mm length)

- SG** → Spring Guard
- AG** → Armour Guard
- AS/PS** → Partek Nylon protective sleeve
- FS** → Fire Sleeves
- HG** → PolyGuard-Hose Protector
- PG** → ParKoil-Hose Protector
- DM** → Minesleeve

Explanation of the example

Hose assembly with hose 462TC in size -6 and fitting series 48.

Hose assembly length 1000 mm.

Fitting 1: end configuration CA has a 12 mm pipe diameter and has a size -6 hose nipple

Fitting 2: end configuration CF has a 10 mm pipe diameter and has a size -6 hose nipple

The displacement angle for this combination is 0 degrees. On request a displacement angle can be specified for the bent fitting in relation with the hose curvature. A protection sleeve as a spring guard in length 900 mm is on the hose assembly.

Ball Valves

with extensive underground experience meet high performance requirements, whilst providing trouble-free service.

Available in 2-way, 3-way and 4-way designs utilizing SteckO® or threaded connections.

This comprehensive range satisfies a variety of mining system control functions.



COALMASTER Ball valves are manufactured in various materials to suit different mediums and environmental conditions.

HOW TO ORDER

Ball Valves

Standad Valve

Example:

CMV10-04-1

CMV10-04-1

CMV10-**04**-1

CMV10-04-**1**

→ Ball Valve Body

→ Connection size

→ Handle Type

Handle Type 1 to 5

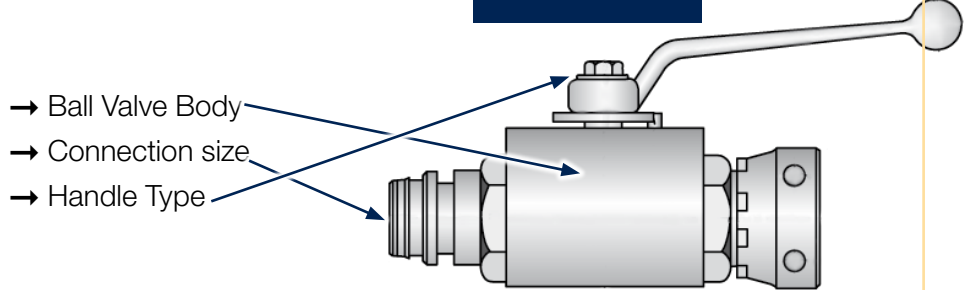

Customized Ball Valve

Example:

CMV10-04-1GN

CMV10-04-1GN

CMV10-**04**-1GN

CMV10-04-**1**GN

CMV10-04-1**GN**

→ Ball Valve Body

→ Connection size

→ Handle Type

→ Colour

Handle Type 1 to 5

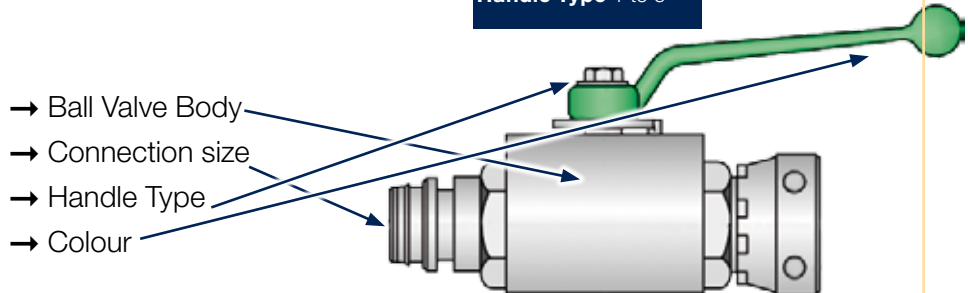

Handle Type

- 1** → Single handle
- 2** → Double handle
- 3** → Hexagon handle
- 4** → Butterfly handle
- 5** → Safety handle

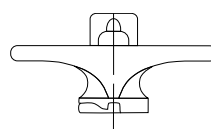
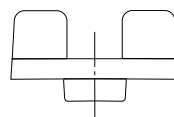
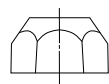
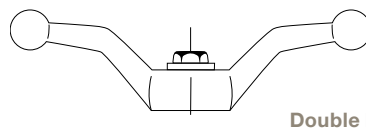
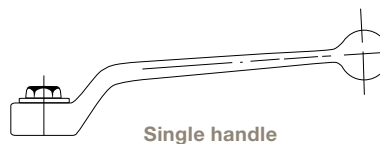

Colour

- (blank) → self / natural
- WT** → white
- GN** → green
- OR** → orange
- RD** → red
- BL** → blue
- YL** → yellow

STAMP

Before you spec it, STAMP it.

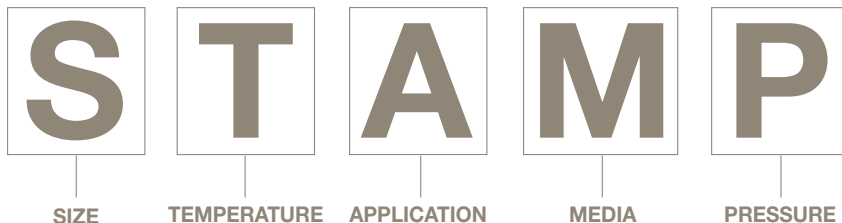

SIZE

Parker uses a system of measurement called Dash Numbers to indicate hose and fitting size. The dash number, or dash size, is the measure of a hose's Inner Diameter (I.D.) in sixteenths of an inch.

This measuring system of the inside diameter of the hose is universally used by the fluid power industry today. Don't know the hose size? Check the layline. If the original printing has worn off, the original hose must be cut and the inside diameter measured. Be sure to measure

the overall assembly length and fitting orientation before cutting the hose.

The hose I.D. must be sized accurately to obtain the proper flow velocity. A flow that's too slow results in sluggish system performance, while a flow that's too high causes excessive pressure drops, system damage, and leaks.

Use the Flow Capacity Nomogram in Section E to determine the proper hose I.D. for an application's flow rate requirements.

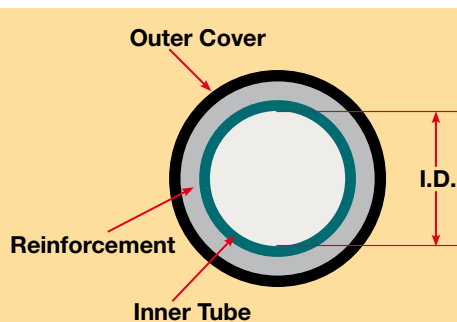

The hose size is determined by the inside diameter which can be measured or found on the layline.

TEMPERATURE

When specifying hose, there are two temperatures you need to identify. One is the **ambient temperature**, which is the temperature that exists outside the hose where it is being used; the other is the **media temperature**, which is the temperature of the media conveyed through the hose.

Very high or low ambient temperatures can have adverse effects on the hose cover and reinforcement materials, resulting in reduced service life.

Media temperatures can have a much greater impact on hose life. For example, rubber loses flexibility if operated at high tem-

peratures for extended periods. Parker hoses carry different temperature ratings for different fluids. For example, 811HT hose has a temperature range of -40°F to +257°F (-40°C to +125°C) for petroleum-based hydraulic fluids. However for water, water/glycol, and water/oil emulsion hydraulic fluids, the range drops to a rating of up to +185°F (+85°C). Air is rated even lower at up to 158°F (+70°C).

Some media can increase or decrease the effects of temperature on the hose. The maximum rated temperature of a hose is specific to the media.



When you order hose and fittings from Parker, remember the word “STAMP.”
That way you won’t forget important information!



APPLICATION

Before selecting a hose, it is important to consider how the hose assembly will be used. Answering the following questions may help:

- **What type of equipment is involved?**
- **What are the environmental factors?**
- **Are mechanical loads applied to the assembly?**
- **Will the routing be confined?**
- **What about hose fittings – No-Skive or ParLock?**
- **Will the assembly be subjected to abrasion?**

Sometimes specific applications require specific hoses. For example, applications where hoses will encounter rubbing or abrasive surfaces, would be best handled by our family of abrasion-resistant hose with both Tough and Super Tough covers.

When application space is tight, bend radius is another important consideration. Parker offers a full line of hoses designed for one-half SAE bend radius at full SAE-rated pressures. We offer hoses with increased flexibility and smaller outer diameters enabling faster, easier routing in small spaces, reducing both hose length and

inventory requirements.

Industry standards set specific requirements concerning construction type, size, tolerances, burst pressure, and impulse cycles of hoses. Parker hydraulic hoses meet or exceed standards such as:

- **SAE (Society of Automotive Engineers)**
- **EN (European Norm)**
- **DIN (Deutsches Institut für Normung)**
- **ISO (International Organization for Standardization)**

Governmental agencies control additional standards for particular industries such as U.S.C.G. and ABS. You must select a hose that meets the legal requirements as well as the functional requirements of the application.



STAMP

When you order hose and fittings from Parker, remember the word “STAMP.” That way you won’t forget important information!

MEDIA

What will the hose convey? Some applications require the use of specialized oils or chemicals. The hose you order must be compatible with the medium being conveyed. Compatibility must cover the inner tube, the cover, hose fit-

tings, and o-rings as well. Use a Chemical Resistance Chart to select the correct components of the hose assembly that will be compatible with your system’s media. The chart contains the chemical resistance rating of a variety of fluids.

PRESSURE

When considering hose pressure, it’s important to know both the system working pressure and any surge pressures and spikes.

Hose selection must be made so that the published maximum working pressure of the hose is equal to or greater than the maximum system pressure. Surge pressures or peak transient pressures in the system must be below the published maximum working pressure for the hose.

Each Parker hose has a pressure rating which can be found on the hose table.

All Parker hydraulic hoses have passed the industry rated speci-

fications for burst pressure and carry a 4:1 design factor unless otherwise noted. Burst pressure ratings for hose are for manufacturing test purposes only.

They are not an indication that the product can be used above the published maximum working pressure.

Care must also be taken when looking at the “weakest link” of the hose assembly. A hose assembly is rated at the maximum working pressure of the hose and the fitting component. Therefore the maximum working pressure of the hose assembly is the lesser of the rated working pressure of the hose and the end connections used.



MAINTENANCE

Preventive Maintenance Programme

Hydraulic hose assemblies are essential components in hydraulic systems and each hose assembly will eventually fail: it's just a matter of when!

Broken hose assemblies often cause loss of earning, downtime and serious personal injuries.

Avoiding failures, losses and risks is definitely your first priority.

Preventive maintenance is needed whenever your hose assemblies show:

- Damaged, cracked, cut or abraded cover
- Exposed reinforcement
- Cracked, damaged or corroded fittings
- Leaks in fitting, sweating hose cover close to fitting
- Kinked, crushed, flattened or twisted hose
- Hard, stiff, cracked or burnt hose
- Blistered, soft, degraded or loose cover
- Fitting slippage on hose

Despite that, hose assemblies are generally underrated overlooked during machine servicing and the need of their preventive maintenance and timely replacement is ignored. This is simple a fact which we can hardly change. But what we can do, however is to help you to provide a hose assembly in the right place and at the right time whenever and wherever you'll need it.

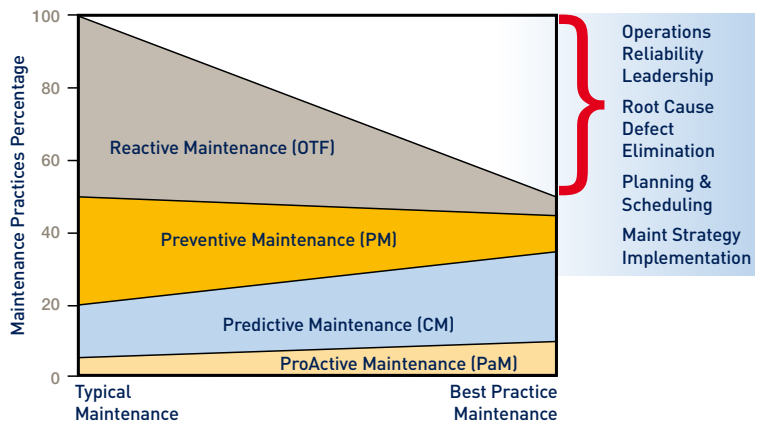

Hint

A good analogy is automobile tyres.

Just like hose, tyres are made of rubber, age with time and experience a lot of strain from the conditions they work in. Most drivers are cautious to replace tyres once they show signs of wear, not leaving it to destiny when they break on the road! So why don't they do it with hydraulic hoses?

As there are countless factors influencing the hose life, there cannot be and are not any exact guidelines to determine when a hose assembly has to be replaced or to judge how long it will work. Yet, we do have a tool to influence and determine the hose life:

**Visual Inspections + Preventive Replacement
= Preventive Maintenance Program!**

Save valuable time



**Parker
Tracking
System**

www.Parker.com/PTS

The Parker Fluid Connectors Group

Take advantage of our connections.

Need help with the big picture? Turn to Parker. As part of the Fluid Connectors Group, we have everything to keep the ideas flowing.

More products

Nobody offers you more than Parker. We have the largest selection of hose, more fitting sizes and configurations than any other manufacturer. Our products deliver the exceptional quality and reliability you've come to expect from us, meeting or exceeding market standards. Plus they're available in a wide choice of materials, designs, shapes, sizes, covers, and capabilities for your specific leak-free performance requirements.

But more parts are only part of what we offer you.

Save valuable time



**Parker
Tracking
System**

www.Parker.com/PTS

More people

Our 2,100 worldwide distributors give you more places to go for more help, faster. Which means when your equipment is down, we're there for you, right near the job site.

Nobody else can equal that kind of convenient service.



Mobile services

Parker is your best bet for on-the-job help. Our mobile services operate 24 hours a day, 7 days a week, to arrive at your plant or job site fast. Complete with factory-trained professionals to troubleshoot your problem. Our mobile vans carry a full complement of hose, all major fitting configurations, and a complete set of metrics — everything that's needed to create a replacement. It's like having your Parker distributor come to you! Find out more at parker.com/distributors.



WE OFFER MORE than innovative products and solutions

We're constantly updating our customer service options to help you work smarter, faster, and better.

Certain customers and applications stipulate the usage of multispiral hose assemblies with external/internal skive-type fittings. With the ParLock hose and fitting range, Parker meets this demanding market requirement. Parker adjustable crimpers for two-piece fittings ensure precise, leak-free and tear-proof assembly of hose and fitting.

Need the Latest? Check Out Our Web site.

From complete product information on hose, to 3D-CAD models of our complete fitting line, you'll find everything you need at www.parkerhose.com. We've redesigned our web site around you. Whether you take advantage of our new product announcements ...or search our site by part number ... you'll find our site easy to navigate and understand.

Our site also provides:

- A listing of government and industry-related approvals.
- Contact technical support. Find out about our custom manufactured products, including customized leakfree tube assemblies.
- Download a wealth of product literature ranging from bulletins and equipment manuals to reference guides and wall charts.

Whatever you do, be sure to visit our site often. It's the fastest and easiest way to keep up with changing technology.

Also Online ... Parker Crimp- source™

Crimpsource enables you to choose your crimper and select the hose, fittings, and current crimping specifications needed to make hose assemblies. You can even print a simple-to-follow data specification sheet. Crimpsource includes hydraulic rubber hose, industrial hose, and thermoplastic hose products, and contains all the crimp specifications approved for Parker crimpers.

Crimpsource is available at www.parker.com/crimpsource.

Training in Hose Products

The extensive training programme of the Hose Products Division Europe contains theoretical and practical training sessions. Training takes place on a regular basis in the different Parker locations. Beside standard training Parker offers the possibility for customized in-house training. The main goal of Parker's product training is to acquire special knowledge about hose products, fittings, connectors and catalogues and will enable you to select efficiently and handle safely all Parker hose products.

HOSE FINDER

The benefits of working with Parker Hose

Bring the power of Parker to the palm of your hand.



- 1 Browse it.** It's easy to use.
- 2 STAMP it.** Use the STAMP search or browse the catalog to find the product you are looking for.
- 3 Search it.** Results include all the details you need to make an informed decision.
- 4 Find it.** Choose the "Find It" link and you'll be directed to one of Parker's 12,000 worldwide distributor locations.

Parker is committed to delivering customer service options to help you work smarter, faster, and better.

Need the latest? Go online. From complete product information on hose, to 3D-CAD models of our complete fitting line, you'll find everything you need at www.parkerhose.com.

And HoseFinder, our mobile app, makes it fast and convenient to search for hydraulic hose products and information on the go. The app features an abbreviated STAMP selection process to help you find what you need quickly and easily. Download yours today at www.hosefinder.com.

Whatever you do, visit our site often. It's the fastest and easiest way to keep up with changing technology and our ever expanding product offering.

Save valuable time



HoseFinder
Parker Hose Selection Guide

HoseFinder is currently available for iPhone®, BlackBerry® and Android™ mobile phones... and at no charge.

Parker Tracking System

Global asset tagging and identification system

The Parker® Tracking System Enterprise (PTS) is designed to help customers reduce vehicle or asset downtime through increases in the speed, timing and accuracy of necessary repairs. PTS provides a unique 8 digit identification code and bar code printed on a durable label for each hose assembly. PTS labels are specifically engineered to withstand harsh chemicals, temperatures, UV exposure and other challenging conditions.

- PTS captures, records and recalls unique hose assembly information – on demand
- Provides fast and accurate product identification to speed up replacement regardless of where the original assembly was made.
- Assembly can be replaced with only the 8 digit PTS ID number/bar code eliminating the need to remove hoses prior to replacement. This can provide critical machine uptime and enable more conveniently scheduled repair.
- PTS includes additional reporting tools to assist in continuous improvement programmes and preventative maintenance initiatives.



Save valuable time

Parker Tracking System

www.Parker.com/PTS



PTS ID: 8 Digit "Unique" Code

PTS ID: Barcode

Assembly Creation Date

Customer Part Number

Customer Defined Text

Customer Part Number: Barcode

TRACKING SYSTEM
Parker.com/PTS 006002725374
PTS ID: PBD3DJUS
Assembly Date: 14/03/2011
Part: 123644S/TS
Customer freeform text here.....
Customer freeform text here.....
Customer freeform text here.....

VALUE ADDED SERVICES

ParkerStore™

At Parker Hannifin, we're continually looking for ways to deliver more products, more efficiently.

The Global ParkerStore™ network enables Parker to provide:

- Prompt, efficient, professional in-store services while you wait
- Expert local services and support
- A safe, friendly and convenient shopping environment
- A greater range of parts options so you get exactly what you're looking for

Customers trust ParkerStores to provide OEM and MRO customers with direct access to:

- Custom-made hydraulic hose assemblies and complementary products to support their applications and decrease their downtime
- Expert technical support
- Professional, personalized services, including 24/7/365 support
- The convenience, comfort and amenities of a local service provider.



ParkerStore™ Container Service



The ParkerStore container is a transportable workshop, providing on-site maintenance and product support for large construction projects such as roadworks, tunnels, railways, underground systems, etc. Provides an on-site product and hose replacement service.

With this service on your site, you can reduce your downtime keeping your project on time and on budget!



Cargo Doors



Storage Racks and Cabinets



Full Electrical Service



Security Doors



Heating/Cooling



Rugged Lighting Service

HOSE DOCTOR®

Parker HOSE DOCTORS® are a network of independently-owned, mobile service technicians built around the commitment to identify and replace hose assemblies wherever their customers need them, with the fastest response times possible.

HOSE DOCTORS® are an extension of the worldwide Parker distribution network, coupling their service commitment with Parker products – the highest quality hoses and fittings available in the market today.



VALUE ADDED SERVICES

Kitting

Multiple components are supplied under a single part number

- Reduced number of suppliers
- Reduced stocks and no obsolete items
- Optimized management (stock and supplies)
- Simplified and optimised order handling
- Reduced assembly costs
- Greater productivity



Tech Services

Optimises the performance of your hydraulic and pneumatic circuits

- With Parker Tech Services involved, your time to market is shorter, which saves on development costs
- The 3 year no-leak guarantee enhances your reputation and lowers your warranty costs
- More reliable operation lowers your customer's operating costs
- More efficient performance and no-leak guarantee is beneficial to the environment
- Parker worldwide coverage ensures you can use the service and save costs wherever you are



Breadman Vendor Managed Inventory

Lean logistics and delivery of Parker products and kits directly to the customer's assembly line, work stations or warehouse

- 100 % parts availability minimises downtime, increases production and reduces costs
- Elimination of stock checking reduces manpower and maintains production levels
- Daily delivery reduces inventory and overheads
- Electronic order processing eliminates paperwork and reduces administration costs
- Enjoy a customized program where Parker personal can manage your inventory in person or remotely
- Reduce overall inventory, increase your inventory turns and increase your efficiency



Improving the Work Place and Saving Energy

Parker is fully engaged in finding ways for the mining industry to increase productivity and profitability and also totally committed to improving the work environment and reducing energy costs.

Parker products are designed and manufactured to prevent fluid leaks, reduce noise and heat, improve fluid cleanliness and condition and remove inert dangerous mine gases.

Parker's fan drive technology consistently delivers increased engine performance with significant reductions in fuel usage. When you need a partner to supply machine productivity and safety along with products that enhance work environments and save energy, Parker should be your first and only choice.



ABRASIVE INFLUENCES

of hose assemblies

right

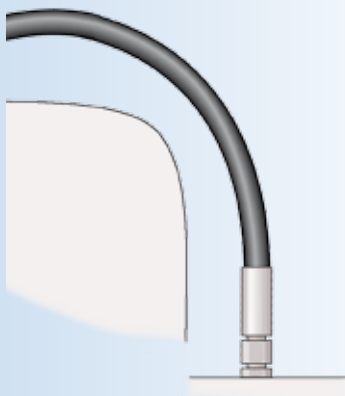

In general care should be taken that the hose is not exposed to direct surface contact that will cause abrasive wearing of the outer cover (either hose to object or hose to hose contact). If however, the application is such that this cannot be avoided, either a hose with a higher abrasion resistant hose cover or a protective sleeve need to be used.

Parker **TOUGH COVER** (TC) and Coalmaster hoses offer 80 times or respectively 450 times the abrasion resistance of standard rubber covers.

wrong

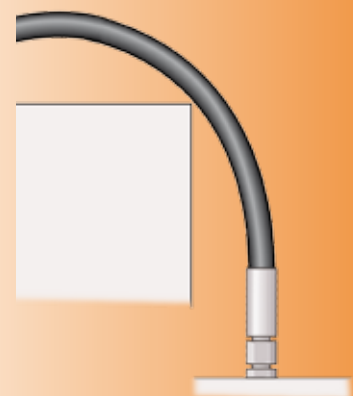

Abrasion? We've got you covered

Our expanded line of abrasion-resistant hose offers you a world of protection, not to mention a choice of covers: Tough Cover (TC) for tough environments; and Coalmaster hoses for the really rough stuff. Our TC covered and Coalmaster hoses can simplify your assemblies by eliminating the need for any additional protective sleeving. From the superior flexibility and tighter bend radius of our wire-braided hoses... to the wide fluid compatibility and high pressure performance of our No-Skive spiral hoses... our expanded family of abrasion-resistant hoses gets the job done right, giving you the results you need in the construction, forestry, mining, injection molding, refuse and recycling, and energy industries.

Metal-to-Hose Abrasion Resistance Comparison

Levels of Abrasion Resistance	Results from the ISO 6945 metal-to-hose abrasion test show that Tough Cover and Super Tough cover hoses offer significantly greater abrasion resistance than standard rubber cover hose.	450 X Coalmaster hoses
	Standard Rubber Cover	

ROUTING

of hose assemblies

right



The routing of the hose assembly and the environment in which the hose assembly operates directly influence the service life of the hose assembly. The following diagrams indicate the correct routing of hose assemblies that will maximise its service life and assure a safe working functionality.

When hose installation is straight, it must be assured that there is enough slack in the hose to allow for changes in length that occur when pressure is applied. When pressurized, hose that is too short may pull loose from its hose fittings or stress the hose fitting connections, causing premature metallic or seal failures.

The hose length must be determined so that the hose assembly has enough slack to allow the system components to move or vibrate without creating tension in the hose.

However, care needs to be taken not to allow too much slack and therefore introduce the risk of the hose snagging on other equipment or rubbing on other components.

Mechanical straining of the hoses needs to be avoided, so the hose must not be bent below its minimum bend radius or twisted during installation. The minimum bending radii for each hose is stated in the hose tables in the catalogue.

The plane of movement must also be considered and the hose routing selected accordingly.

Hose routing also plays an important role on the selection of the hose fittings, as the correct fittings can avoid straining the hoses, unnecessary hose length or multiple threaded joints.

wrong



INSTALLATION

of hose assemblies

right

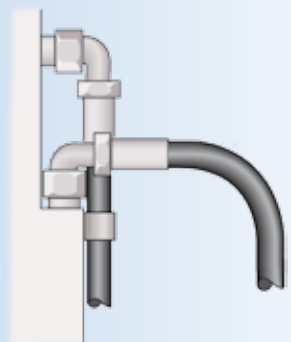
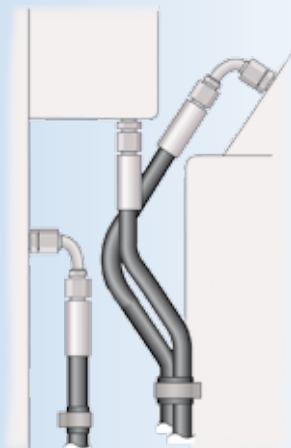
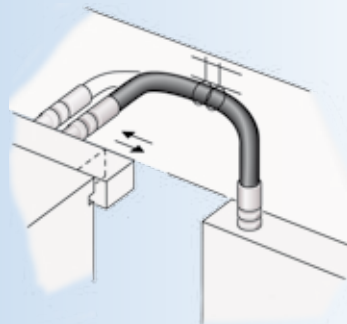
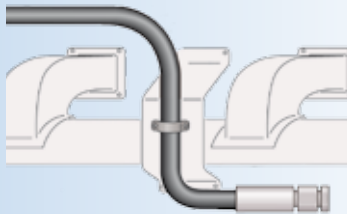

Correct clamping (holding/supporting) of the hose should be exercised to securely route the hose or to avoid the hose contacting surfaces that will cause the hose damage.

It is however, vital that the hose be allowed to keep its functionality as a “flexible-pipe” and not be restricted from changing in length when under pressure.

It should also be noted that hoses for high- and low-pressure lines shall not be crossed or clamped together, as the difference in changes in length could wear the hose covers.

Hose should not be bent in more than one plane. If hose follows a compound bend, it shall be coupled into separate segments or clamped into segments that each flex in only one plane.

Hoses should be kept away from hot parts as high ambient temperatures shorten hose life.

Protective insulation may need to be used in unusually high ambient temperature areas.

Whilst the importance of the functionality is prime the aesthetics and practicality of the installation should also be considered in the design.

It should be considered that maintenance might be necessary at some stage in the future, so prohibitive design routings should be avoided.

wrong

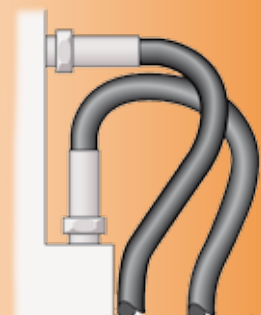
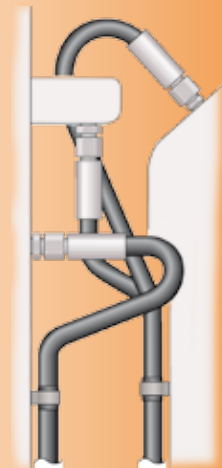
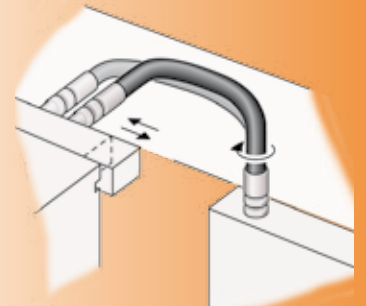

SAFETY FIRST!

A hydraulic hose assembly is a power component and may cause property damage, personal injury or death!

WARNING: Injuries in which hydraulic or other liquid is involved must be treated without delay and not the same way as an ordinary injury!

1. High pressure fluid injection can be almost invisible, leaking from a pinhole, but it can pierce the skin deep into the muscle!
2. If a fluid-injection accident occurs, search immediately for a medical treatment by a doctor!
3. Don't touch pressurized hydraulic hose assemblies and don't look at them from a short distance
– especially not close to fittings!
4. Secure ends of hydraulic assemblies with high pulsing pressure and all high pressure air hose assemblies against blow-off of the hose from the fitting with appropriate whip restraints!
5. Stay out of hazardous areas while testing hose assemblies under pressure and wear proper protective clothing and goggles!

- **READ CAREFULLY AND OBSERVE**

- **Parker Safety Guide** for Selecting and Using Hose, Tubing, Fittings and Related Accessories

- **INVESTIGATE, STUDY AND OBSERVE all relevant international and national standards and directives** of your local trade, technical and work safety associations, such as:

- **ISO 17165-1** *Hydraulic Fluid Power – Hose Assemblies*
- **ISO 17165-2** *Hydraulic Fluid Power – Hose Assemblies*
- **ISO 4413** *Hydraulic Fluid Power – General rules and safety requirements (systems/ components)*
- **SAE J1273** *Recommended Practices for Hydraulic Hose Assemblies*

- in Germany**

- **BGR 237** *Hydraulik-Schlauchleitungen – Regeln für den sicheren Einsatz*
- **FA 015** *Hydraulik-Schlauchleitungen Prüfen und Auswechseln*
- **BGI 5100** *Sicherheit bei der Hydraulik-Instandhaltung*

- in UK**

- **BFPDA D8** *Quality Control Procedures and Requirements for BFPDA Distributors*
- **BFPDA D14** *A Simple Rule for Re-ending Hydraulic Hose Assemblies – Don't*
- **BFPDA P47** *Guidelines for the Use of Hydraulic Fluid Power Hose and Hose Assemblies*
- **BritishCoal** *British organisation for safety in the mining industry*

- in Poland**

- **GIG** *The Central Mining Institute (in Polish: Główny Instytut Górnictwa, acronym: GIG) is a scientific and development organization, subordinated to the Minister of Economy, GIG is in possession of a broad offer with respect to: risk assessment, safety reports, industrial safety management system, measurements and work environment hazard control regarding industrial installations, informatic programmes supporting actions in the field of industrial safety.*

- in Asia**

- **MDG41** *Mechanical Design Guideline for Fluid power system safety and Mines by NSW Department*

- in China**

- **MA** *Mining Products Safety Approval and Certification Center (MA Center) is independent legal entity organization authorized by State Administration of Work Safety (SAWS). MA Center approves and certifies safety of certain mining products.*

We in Parker are making all efforts to develop, manufacture and deliver defect-free, durable and safe products and services – starting from integrated design and testing of all components through sharing our know-how with our customers and providing them with comprehensive support and training

Please also make all efforts on your side to provide reliable and safe hose assemblies to your customers and forward to them the know-how you acquired, whether from us or due to your own unique experience, especially as regards the proper use and maintenance of hose assemblies.

Hose and Fittings Storage

It is a well-known fact that rubber properties deteriorate during the time of storage and service. A system of hose age control should be maintained to ensure that hose is used as long as it retains full capabilities for rendering the intended service.

However, it is impossible to advise the ideal storage period and service life of rubber hose as it is subject to a variety of factors which may affect the rubber characteristics and the suitability for use.

That is also why various standardization committees take very different approaches to rubber hose storage period and service life. The main national and international standards defining rules for rubber hose storage are the following:

DIN 20066

Fluid power systems – Hose assemblies – Dimensions, requirements

Specifies bulk hose shelf life and hose assembly storage period and service life:

- The shelf life of bulk hose before assembling must not exceed 4 years.
- The service life of a hose assembly, incl. any period of storage, must not exceed 6 years.
- The period of storage of a hose assembly must not exceed 2 years.

Bulk Hose

Shelf life
– max. 4 years

Hose Assembly

Service life – max. 6 years
Storage
max. 2 years

BS 5244

Recommendations for application, storage and life expiry of hydraulic rubber hoses and hose assemblies

Specifies tests needed for various storage periods of hose (in bulk or hose assembly):

- Storage period does not exceed 3 years – no tests needed.
- Storage period is between 3 and 5 years – proof pressure test needed.
- Storage period is between 5 and 8 years – proof pressure, burst, impulse, cold flexibility and electrical tests needed.
- Bulk hose or a hose assembly older than 8 years – must be scrapped.

For hose assembly service life no explicit limits are specified, whereas it is recommended to establish rules for each particular equipment and application on the basis of records taken from the real service.

ISO 17165-2 / SAE J1273

Hydraulic fluid power – Hose assemblies – Recommended practices for hydraulic hose assemblies

The specified max. shelf life of bulk hose or a hose assembly is 10 years (40 quarters) from the date of manufacture (vulcanization) of the hose, provided it has been stored in accordance with ISO 2230 (Rubber products - Guidelines for storage) and passes visual inspection and if need be also a proof pressure test.

If visual inspection gives rise to any doubts as to the functionality of the hose (cracks in the cover or tube after hose flexing, excessive stiffness, reinforcement rust etc.), a proof pressure test should be carried out before use or the hose should be scrapped.

MDG41

**Mechanical Design Guide-
line for Fluid power system
safety at Mines. Nominates
industry best practises for
risk management design,
cradle to grave.**



ISO 8331

Rubber and plastic hoses and hose assemblies – Guide to selection, storage, use and maintenance

Specifies storage periods similar to DIN 20066 – bulk hose max. 4 years, a hose assembly max. 2 years. If the storage exceeds these limits the hose must be inspected and tested (tests are not specified). Hose assembly service life is not specified.

OEM regulations

In addition to these national and international standards, also some Original Equipment Manufacturers (OEMs) have their own regulations for age of hose used for production of hose assemblies. We recommend generally observe the regulations relevant for your country or ISO 17165-2 (if there is no domestic regulation), plus the regulation of your customer's country or of your OEM customer in the extent in which they are more demanding.

Hoses storage – best practices

Store hoses and hose assemblies in a cool, dark and dry room with capped ends in closed boxes (preferably in the original Parker packaging) and in the manner facilitating inspection of the hose condition and the first-in first-out (FIFO) inventory control system. The main factors determining the hose storage are:

Temperature Preferably between 15 °C and 25 °C, without rapid and frequent fluctuation.

Humidity Preferably not higher than 65 %, protect hose against moisture and avoid atmospheric humidity condensation.

Heat Store hose away from heat sources.

Light Protect hose against direct sun light, light of discharge lamps and other ultra-violet sources.

Corrosive liquids and fumes Do not store in the same room with corrosive chemicals.

Ozone Avoid using high power electrical equipment and electrical spark sources in the storage room.

Oils and greases Avoid direct contact.

Space and bends Keep hose in stress-free shape never bent below the min. bend radius.

Electrical and magnetic fields Store hose away from powerful electric transformers, motors and generators that could induce current in the hose metal reinforcement.

Rodents and insects Protect against rodents and insects.

Fittings storage – best practices

For storing fittings the same rules as for hose are applicable (especially for fittings with rubber sealing), in addition:

Mismatching and confusing Avoid unnecessary repacking and store fittings in clearly marked closed containers (preferably in the original Parker packaging).

Damage of threads and sealing surfaces Avoid unnecessary reloading and handling.

Fittings with O-rings Assure that storage period of fittings with O-rings or other rubber sealing does not exceed 2 years (remember: first in-first out).

Caps Hose assemblies fittings should be capped against damage and contamination.





MINING HOSE

Parker Hannifin offers a complete range of mining hydraulic hoses for high pressure, medium pressure and return line applications.

Well known hose brand names like COALMASTER, Elite Compact Tough Cover, Compact Spiral™, Parkrimp No-Skive and ParLock Multispiral are specially designed for the heavy duty mining applications, Longwall, Continuous Miners, Tunnel boring, Rock Driller (Underground), Load Haul Dump – LHD's, Surface Mining and Rock Driller. All hose types feature important characteristics like high abrasion, ozone and ageing, oil weather and flame resistance.

The offered hose types are approved by the most important world wide mining safety institutes.

Product	Feature	Major Benefits	Certification
COALMASTER Hose	Abrasion resistant MSHA cover	Long service life, Compact hose routing	MSHA, BritishCoal
Elite Compact Tough Cover Hose	Exceeds European specifications, highly flexible, tight bending radii, compact thin cover, temperature range up to +125°C and down to -50 °C, extreme abrasion resistance	Higher abrasion resistance, higher pressure ratings	MSHA
Compact Spiral™ Hose	1/2 bend radius, 1,000,000 cycle life evolutionary flexibility, smaller physical size constant pressure across all sizes	Ease of installation, 1/2 SAE bend, tighter routing, better flexibility, longer performance life	MSHA
Parkrimp No-Skive Hose	Complete system from one source for fast and leak-free assemblies, No-Skive hose, fittings and crimping machine with world-wide guarantee and availability.	No skiving tool needed, no need to remove the hose cover, Parkalign positions the one-piece fitting in the dies perfectly every time, meets EN safety regulations	MSHA, OBAC
ParLock Hose	ParLock: the high performance skive system for extremely dynamic pressure applications	ParLock hose and fittings combination giving high performance and safety through design	MSHA, OBAC



Mining Hoses Overview

Medium Pressure

COALMASTER

CM2H



Coalmaster Style

CM2HP



Coalmaster Style

Standard MSHA approved

301TC



No-Skive Tough Cover
EN 853 2SN – ISO 1436 Type 2

462TC



Elite No-Skive Compact Tough Cover
Exceeds EN 857-2SC – ISO 11237 Type 2SC

436



No-Skive Compact
SAE 100R16 high temperature

High Pressure

COALMASTER

CM4SPP



No-Skive Multispiral
ISO 3862 Type 4SP –
DIN EN 856 Type 4SP

CM4SHP



No-Skive Multispiral
ISO 3862 Type 4SH – DIN
EN 856 Type 4SH

CM4R42P



ParLock Multispiral
Exceeds ISO 3862 Type R15 –
Parker Specifications

Standard MSHA approved

722TC



No-Skive Tough Cover
SAE 100R12 – EN 856 Type R12 –
ISO 3862 Type R12

731TC



No-Skive Multispiral
ISO 3862 Type 4SH – EN 856 Type 4SH

787TC



No-Skive Compact Spiral™
Exceeds ISO 18752-DC

797TC



No-Skive Compact Spiral™
Sizes -8 to -20 exceed ISO 18752-DC
Sizes -24 and -32 exceed ISO 18752-CC

R35TC/RS35TC-48



ParLock Multispiral
Exceeds ISO 3862 Type R13 –
Parker Specifications

Suction & Return

881



No-Skive Suction and Return Line
SAE 100R4

Hose Pressure Ratings

		Hose	Fitting Series	Working Pressure (MPa) in Size												Temp.	Construction	Standard	Page	
				-4	-5	-6	-8	-10	-12	-16	-20	-24	-32	-40	-48					
Medium Pressure	COALMASTER	2-wire standard	CM2H	43	42.5	35.0	31.0		28.0	21.0	17.0	14.6	11.2	7.0	7.0	-40 / +100	2 braids wire		B-1	
		2-wire Super Tough	CM2HP	43	42.5	35.0	31.0		28.0	21.0	17.0	14.6	11.2	7.0	7.0	-40 / +100	2 braids wire		B-2	
	Standard MSHA approved	2-wire SN Tough cover	301TC	48	40.0	35.0	33.0	27.5	25.0	21.5	18.5	12.5	9.0	8.0			-40 / +100	2 braids wire	EN 853 2SN ISO 1436 Type 2 SAE 100R2AT	B-3
		2-wire SC Tough cover	462TC	48	42.5	40.0	35.0	31.0	28.0	28.0	21.0	17.0	14.6	11.2	7.0	7.0	-40 / +100	2 braids wire	Exceeds EN 857 2SC ISO 11237 Type 2SC	B-4
		2-wire No Skive Compact SAE 100R16	436	48			27.5	24.0	19.0	15.5	13.8						-48 / +150	2 braids wire	SAE 100R16	B-5
High Pressure	COALMASTER	4-spiral 4SP	CM4SPP	70		45.0	41.5		35.0							-40 / +100	4 spiral wire	ISO 3862 Type 4SP EN 856 Type 4SP	B-6	
		4-spiral 4SH	CM4SHP	73						43.4	40.3	35.4	31.3	28.1			-40 / +100	4 spiral wire	ISO 3862 Type 4SH EN 856 Type 4SH	B-7
		4/6 spiral R15	CM4R42P	V4 V6							42.0	42.0	42.0	42.0			-40 / +125	4/6 spiral wire	Exceeds ISO 3862 Type R15 Parker Specifications	B-8
	Standard MSHA approved	4-wire R12 Tough cover	722TC	43			28.0	28.0	28.0	28.0	28.0						-40 / +125	4 spiral wire	SAE 100R12 EN 856 Type R12 ISO 3862 Type R12	B-9
		4-wire 4SH	731TC	73						42.0	38.0	32.0	29.0	25.0			-40 / +100	4 spiral wire	3862 Type 4SH EN 856 Type 4SH	B-10
		4-/6-wire R13 Tough cover	787TC	77			35.0	35.0	35.0	35.0	35.0	35.0	35.0				-40 / +125	4/6 spiral wire	SAE 100R13 ISO 3862 Type R13 ISO 18752-DC	B-11
		6-wire R13 Tough cover Big bore Parlock Compact Spiral™	R35TC/ RS35TC-48	V6											35.0	35.0 21.0	-40 / +125	4/6 spiral wire	Exceeds ISO 3862 Type R13 Parker Specifications	B-13
		4-/6-wire R15 Tough cover	797TC	77			42.0	42.0	42.0	42.0	42.0	42.0	42.0				-40 / +125	4/6 spiral wire	SAE 100R15 ISO 3862 Type R15 ISO 18752-DC	B-12
		100R4 High Temp textile braided	881	43 48						2.1	1.7	1.4	1.0	0.7	0.4		-40 / +121	2 fibre spiral, 1 helical wire	SAE 100R4	B-14



CM2H

Coalmaster Style



- *No-Sliver* hose construction
- MSHA approved
- High flexible 2-wire construction

Primary Applications

Mining

Applicable Specifications

MSHA, British Coal

Construction

Tube: Synthetic seamless oil resistant
Reinforcement: Two braids of high tensile steel wire
Cover: Oil, weather, flame resistant

Recommended Fluids

Petroleum and water-glycol based fluids, lubricating oils, air and water. For air above 1.7 MPa, the hose cover must be pin-pricked.

Temperature Range -40 °C up to +100 °C

Fitting Series

Size -4 up to -32

Size -40 & -48



2piece series 48

Part Number	Hose I.D.				Hose O.D. mm	Pressure Rating				min. bend radius mm	weight kg
	DN	Inch	Size	mm		max. working pressure		min. burst pressure			
						MPa	psi	MPa	psi		
CM2H-4	6	1/4	-4	6.4	15.2	45.0	6525	180.0	26100	100	0.42
CM2H-6	10	3/8	-6	9.5	19.2	37.9	5500	151.7	22000	130	0.62
CM2H-8	12	1/2	-8	12.7	21.8	36.2	5250	144.8	21000	150	0.73
CM2H-12	19	3/4	-12	19.1	29.0	27.6	4000	110.3	16000	230	1.06
CM2H-16	25	1	-16	25.4	37.7	21.4	3110	85.8	12440	300	1.61
CM2H-20	31	1 1/4	-20	31.8	44.5	17.2	2495	68.8	9980	335	1.80
CM2H-24	38	1 1/2	-24	38.1	52.0	14.6	2118	58.4	8472	400	2.20
CM2H-32	51	2	-32	50.8	64.0	11.2	1624	44.8	6496	500	2.90
CM2H-40	63	2 1/2	-40	63.5	76.0	7.0	1015	28.0	4060	760	3.00
CM2H-48	76	3	-48	76.2	87.5	7.0	1015	28.0	4060	760	3.30

Replace the hose when any deformation or damage on the hose cover are visible.
The combination of high temperature and high pressure could reduce the hose life.

CM2HP

Coalmaster Style



- *No-Skive* hose construction
 - MSHA approved
 - High flexible 2-wire construction
 - Extreme abrasion resistant
- SUPER TOUGH** cover

Primary Applications

Mining

Type Approvals

MSHA, British Coal

Construction

Tube: Synthetic seamless oil resistant
 Reinforcement: Two braids of high tensile steel wire
 Cover: Oil, weather, flame resistant, with a polyethelene abrasion resistant MSHA approved cover

Recommended Fluids

Petroleum and water-glycol based fluids, lubricating oils, air and water. For air above 1.7 MPa, the hose cover must be pin-pricked.

Temperature Range -40 °C up to +100 °C

Fitting Series

Size -4 up to -32

Size -40 & -48



2piece series 48

Part Number	Hose I.D.				Hose O.D. mm	Pressure Rating				min. bend radius mm	weight kg
	DN	Inch	Size	mm		max. working pressure		min. burst pressure			
						MPa	psi	MPa	psi		
CM2HP-4	6	1/4	-4	6.4	15.2	45.0	6525	180.0	26100	100	0.42
CM2HP-6	10	3/8	-6	9.5	19.2	37.9	5500	151.7	22000	130	0.62
CM2HP-8	12	1/2	-8	12.7	21.8	36.2	5250	144.8	21000	150	0.73
CM2HP-12	19	3/4	-12	19.1	29.0	27.6	4000	110.3	16000	230	1.06
CM2HP-16	25	1	-16	25.4	37.7	21.4	3110	85.8	12440	300	1.61
CM2HP-20	31	1 1/4	-20	31.8	47.0	17.2	2500	69.0	10000	380	2.10
CM2HP-24	38	1 1/2	-24	38.1	54.0	14.5	2100	57.9	8400	450	2.65
CM2HP-32	51	2	-32	50.8	66.8	11.2	1625	44.8	6500	600	3.25
CM2HP-40	63	2 1/2	-40	63.5	76.0	7.0	1015	28.0	4060	760	3.00
CM2HP-48	76	3	-48	76.2	87.5	7.0	1015	28.0	4060	760	3.30

Replace the hose when any deformation or damage on the hose cover are visible.
 The combination of high temperature and high pressure could reduce the hose life.

301TC

No-Skive Tough Cover

EN 853 2SN – ISO 1436 Type 2

Primary Applications

General medium pressure hydraulic applications where high abrasion is required

Type Approvals

MSHA, OBAC

Applicable Specifications

EN 853 2SN – ISO 1436 Type 2 – SAE 100R2AT

Construction

Tube: Nitrile (NBR)
Reinforcement: Two high-tensile steel wire braids
Cover: MSHA approved synthetic rubber

Temperature Range -40 °C up to +100 °C

Exception: Air max. +70 °C
Water max. +85 °C



- *No-Skive* thin cover hose construction
- Nitrile (NBR) inner tube – extended fluid compatibility
- Highly abrasion resistant **TOUGH COVER**
- MSHA approved
- Hose is suitable for temporary immersion in mineral oil up to 70 °C with frequent inspections

Recommended Fluids

Petroleum and water-glycol based fluids, lubricating oils, air and water. For air above 1.7 MPa, the hose cover must be pin-pricked.

Fitting Series



Part Number	Hose I.D.				Hose O.D. mm	Pressure Rating				min. bend radius mm	weight kg
	DN	Inch	Size	mm		max. working pressure		min. burst pressure			
						MPa	psi	MPa	psi		
301TC-4	6	1/4	-4	6.4	15.0	40.0	5800	160.0	23200	100	0.39
301TC-5	8	5/16	-5	7.9	16.6	35.0	5075	140.0	20300	115	0.42
301TC-6	10	3/8	-6	9.5	19.0	33.0	4775	132.0	19100	130	0.55
301TC-8	12	1/2	-8	12.7	22.2	27.5	4000	110.0	16000	180	0.67
301TC-10	16	5/8	-10	15.9	25.4	25.0	3600	100.0	14500	200	0.77
301TC-12	19	3/4	-12	19.1	29.3	21.5	3100	86.0	12400	240	1.00
301TC-16	25	1	-16	25.4	38.1	16.5	2400	66.0	9600	300	1.49
301TC-20	31	1 1/4	-20	31.8	47.5	12.5	1800	50.0	7200	420	1.73
301TC-24	38	1 1/2	-24	38.1	55.0	9.0	1300	36.0	5200	500	2.14
301TC-32	51	2	-32	50.8	67.0	8.0	1150	32.0	4600	630	2.96

Replace the hose when any deformation or damage on the hose cover are visible. The combination of high temperature and high pressure could reduce the hose life.

462TC

Elite *No-Skive* Compact Tough Cover

Exceeds EN 857-2SC – ISO 11237 Type 2SC

Primary Applications

Demanding medium pressure hydraulic applications in all markets

Type Approvals

MSHA, OBAC (for size -40, -48 only)

Applicable Specifications

Exceeds EN 857-2SC – ISO 11237 Type 2SC

Construction

Tube: Nitrile (NBR)
Reinforcement: Two high-tensile steel wire braids
Cover: MSHA approved synthetic rubber

Temperature Range -40 °C up to +100 °C

Exception: Air max. +70 °C

Water max. +85 °C



- *No-Skive* hose construction – Compact design
- Nitrile (NBR) inner tube – extended fluid compatibility
- Exceeding EN/ISO specifications for pressure, bend radius and abrasion resistance
- Highly abrasion resistant **TOUGH COVER**
- MSHA approved

Recommended Fluids

Petroleum and water-glycol based fluids, lubricating oils, air and water. For air above 1.7 MPa, the hose cover must be pin-pricked.

Fitting Series

Size -4 up to -32



Size -40 & -48

2piece series 48

Part Number	Hose I.D.				Hose O.D. mm	Pressure Rating				min. bend radius mm	weight kg
	DN	Inch	Size	mm		max. working pressure		min. burst pressure			
						MPa	psi	MPa	psi		
462TC-4	6	1/4	-4	6.4	13.4	42.5	6160	170.0	24640	75	0.30
462TC-5	8	5/16	-5	7.9	15.0	40.0	5800	160.0	23200	85	0.35
462TC-6	10	3/8	-6	9.5	17.2	35.0	5075	140.0	20300	90	0.42
462TC-8	12	1/2	-8	12.7	20.4	31.0	4495	124.0	17980	130	0.52
462TC-10	16	5/8	-10	15.9	23.9	28.0	4060	112.0	16240	160	0.66
462TC-12	19	3/4	-12	19.1	27.7	28.0	4060	112.0	16240	195	0.86
462TC-16	25	1	-16	25.4	35.4	21.0	3045	84.0	12180	250	1.17
462TC-20	31	1 1/4	-20	31.8	45.1	17.2	2495	68.8	9980	335	1.80
462TC-24	38	1 1/2	-24	38.1	52.0	14.6	2118	58.4	8472	400	2.20
462TC-32	51	2	-32	50.8	64.0	11.2	1624	44.8	6496	500	2.90
462TC-40	63	2 1/2	-40	63.5	76.0	7.0	1015	28.0	4060	760	3.00
462TC-48	76	3	-48	76.2	87.5	7.0	1015	28.0	4060	760	3.30

Part Number without a suffix: the hose cover has a smooth appearance. Part Number with a suffix (WR): the hose cover has a wrapped appearance. The combination of high temperature and high pressure could reduce the hose life.

436

No-Skive Compact

SAE 100R16 high temperature

Primary Applications

Medium pressure hydraulic applications at high temperature

Type Approvals

MSHA

Applicable Specifications

SAE 100R16

Construction

Tube: PKR synthetic rubber
Reinforcement: Two high-tensile steel wire braids
Cover: MSHA approved blue synthetic rubber

Temperature Range -48 °C up to +150 °C

Exception: Air max. +70 °C
Water, water glycol fluids .. max. +85 °C



- *No-Skive* thin cover hose construction
- Compact hose construction with tight bend radius
- MSHA approved
- Ideal for high temperature applications

Recommended Fluids

Petroleum hydraulic fluids, lubricating oils, water-glycol based fluids, air and water.

Fitting Series



Part Number	Hose I.D.				Hose O.D. mm	Pressure Rating				min. bend radius mm	weight kg
	DN	Inch	Size	mm		max. working pressure		min. burst pressure			
						MPa	psi	MPa	psi		
436-6-BLU-RL	10	3/8	-6	9.5	17.0	27.5	4000	110.0	16000	65	0.42
436-8-BLU-RL	12	1/2	-8	12.7	20.0	24.0	3500	96.0	14000	90	0.51
436-10-BLU-RL	16	5/8	-10	15.9	24.0	19.0	2750	76.0	11000	100	0.66
436-12-BLU-RL	19	3/4	-12	19.1	28.0	15.5	2250	62.0	9000	120	0.80
436-16-BLU-RL	25	1	-16	25.4	36.0	13.8	2000	55.0	8000	150	1.22

The combination of high temperature and high pressure could reduce the hose life.
RL = only available on reels.

CM4SPP

No-Skive Multispiral

ISO 3862 Type 4SP – EN 856 Type 4SP

Primary Applications

General high pressure hydraulic applications

Type Approvals

MSHA, British Coal

Applicable Specifications

ISO 3862 Type 4SP – EN 856 Type 4SP

Construction

Tube: Synthetic rubber
Reinforcement: Four spirals high-tensile steel wire
Cover: Synthetic rubber with special polyethylene coating

Temperature Range -40 °C up to +100 °C

Exception: Air max. +70 °C

Water max. +85 °C



- *No-Skive* hose construction
- Extreme abrasion resistant **SUPER TOUGH** cover
- Reinforcement of four high tensile steel wires

Recommended Fluids

Petroleum and water-glycol based fluids, lubricating oils, air and water. For air above 1.7 MPa, the hose cover must be pin-pricked.

Fitting Series



Part Number	Hose I.D.				Hose O.D. mm	Pressure Rating				min. bend radius mm	weight kg
	DN	Inch	Size	mm		max. working pressure		min. burst pressure			
						MPa	psi	MPa	psi		
CM4SPP-6	10	3/8	-6	9.5	21.4	45.0	6500	180.0	26000	180	0.78
CM4SPP-8	12	1/2	-8	12.7	24.6	41.5	6000	166.0	24000	230	0.93
CM4SPP-12	19	3/4	-12	19.1	32.2	35.0	5000	140.0	20000	300	1.58

The combination of high temperature and high pressure could reduce the hose life.

CM4SHP

No-Skive Multispiral

ISO 3862 Type 4SH – EN 856 Type 4SH

Primary Applications

General high pressure hydraulic applications

Type Approvals

MSHA, British Coal

Applicable Specifications

ISO 3862 Type 4SH – EN 856 Type 4SH

Construction

Tube: Synthetic rubber
Reinforcement: Four spirals high-tensile steel wire
Cover: Synthetic rubber with special polyethylene coating

Temperature Range -40 °C up to +100 °C

Exception: Air max. +70 °C

Water max. +85 °C



- *No-Skive* hose construction
- Extreme abrasion resistant **SUPER TOUGH** cover
- Reinforcement of four high tensile steel wires

Recommended Fluids

Petroleum hydraulic fluids, lubricating oils, water-glycol based fluids, air and water.

Fitting Series



Part Number	Hose I.D.				Hose O.D. mm	Pressure Rating				min. bend radius mm	weight kg
	DN	Inch	Size	mm		max. working pressure		min. burst pressure			
						MPa	psi	MPa	psi		
CM4SHP-12	19	3/4	-12	19.1	31.6	43.4	6250	172.4	25000	280	1.70
CM4SHP-16	25	1	-16	25.4	37.8	40.3	5800	160.0	23200	340	2.20
CM4SHP-20	31	1 1/4	-20	31.8	44.6	35.4	5100	140.7	20400	460	2.55
CM4SHP-24	38	1 1/2	-24	38.1	53.1	31.3	4500	124.1	18000	560	3.40
CM4SHP-32	51	2	-32	50.8	67.6	28.1	4050	111.7	16200	700	4.80

The combination of high temperature and high pressure could reduce the hose life.

CM4R42P

ParLock Multispiral

Exceeds ISO 3862 Type R15 –
Parker Specifications

Primary Applications

General high pressure hydraulic applications

Type Approvals

MSHA, British Coal

Applicable Specifications

Exceeds ISO 3862 Type R15 – Parker Specifications

Construction

Tube: Synthetic rubber
Reinforcement: Four or six spirals high-tensile steel wire
Cover: Synthetic rubber with special polyethylene coating

Temperature Range -40 °C up to +125 °C

Exception: Air max. +70 °C
Water max. +85 °C



- Interlock technology
- Extreme abrasion resistant **SUPER TOUGH** cover
- Reinforcement of four or six high tensile steel wires
- Constant working pressure of 42.0 MPa

Recommended Fluids

Petroleum and water-glycol based fluids, lubricating oils, air and water. For air above 1.7 MPa, the hose cover must be pin-pricked.

Fitting Series

Internal and external skiving (size -16)



Internal and external skiving (size -20, -24, -32)



Part Number	Hose I.D.				Hose O.D. mm	Pressure Rating				min. bend radius mm	weight kg
	DN	Inch	Size	mm		max. working pressure MPa	psi	min. burst pressure MPa	psi		
CM4R42P-16	25	1	-16	25.4	39.00	42.0	6000	168.0	24000	300	2.30
CM4R42P-20	31	1 1/4	-20	31.8	50.75	42.0	6000	168.0	24000	400	3.80
CM4R42P-24	38	1 1/2	-24	38.1	57.00	42.0	6000	168.0	24000	500	4.80
CM4R42P-32	51	2	-32	50.8	71.50	42.0	6000	168.0	24000	700	7.00

The combination of high temperature and high pressure could reduce the hose life.

722TC

No-Skive Tough Cover

SAE 100R12 - EN 856 Type R12 - ISO 3862 Type R12

Primary Applications

Transportation, construction, forestry

Type Approvals

MSHA

Applicable Specifications

SAE 100R12 - EN 856 Type R12 - ISO 3862 Type R12

Construction

Tube: Synthetic rubber
Reinforcement: Four spirals high-tensile steel wire
Cover: High abrasion resistance
MSHA approved synthetic rubber

Temperature Range -40 °C up to +125 °C

Exception: Air max. +70 °C
Water max. +85 °C

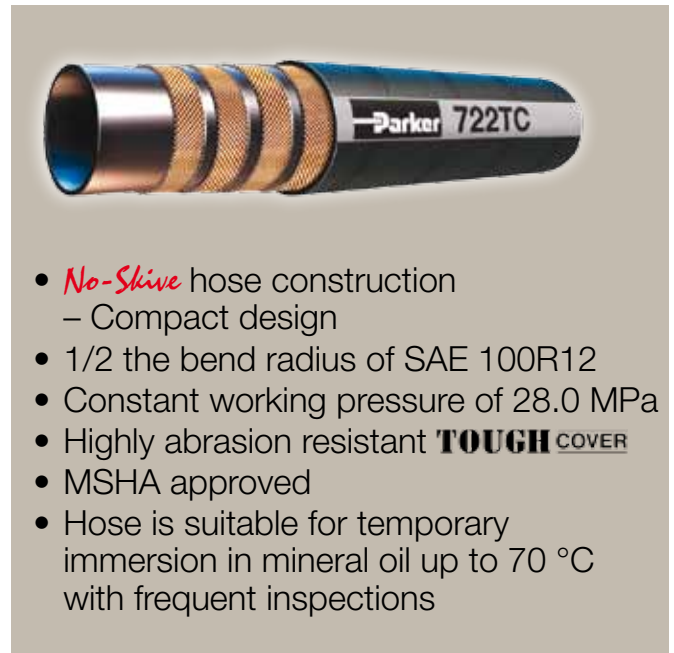

- *No-Skive* hose construction – Compact design
- 1/2 the bend radius of SAE 100R12
- Constant working pressure of 28.0 MPa
- Highly abrasion resistant **TOUGH COVER**
- MSHA approved
- Hose is suitable for temporary immersion in mineral oil up to 70 °C with frequent inspections

Recommended Fluids

Petroleum and water-glycol based fluids, lubricating oils, air and water. For air above 1.7 MPa, the hose cover must be pin-pricked.

Fitting Series



Part Number	Hose I.D.				Hose O.D. mm	Pressure Rating				min. bend radius mm	weight kg
	Hose I.D.					max. working pressure MPa	min. burst pressure		min. bend radius mm		
	DN	Inch	Size	mm			psi	MPa			
722TC-6	10	3/8	-6	9.5	20.0	28.0	4000	112	16000	65	0.60
722TC-8	12	1/2	-8	12.7	24.0	28.0	4000	112	16000	90	0.80
722TC-10	16	5/8	-10	15.9	27.0	28.0	4000	112	16000	100	1.10
722TC-12	19	3/4	-12	19.1	31.0	28.0	4000	112	16000	120	1.40
722TC-16	25	1	-16	25.4	38.0	28.0	4000	112	16000	150	1.99

Replace the hose when any deformation or damage on the hose cover are visible.
The combination of high temperature and high pressure could reduce the hose life.

731TC

No-Skive Multispiral

ISO 3862 Type 4SH – EN 856 Type 4SH

Primary Applications

General high pressure hydraulic applications

Type Approvals

MSHA, OBAC

Applicable Specifications

ISO 3862 Type 4SH – EN 856 Type 4SH

Construction

Tube: Synthetic rubber
Reinforcement: Four spirals high-tensile steel wire
Cover: High abrasion resistance
MSHA approved synthetic rubber

Temperature Range -40 °C up to +100 °C

Exception: Air max. +70 °C

Water max. +85 °C



- *No-Skive* hose construction
- Reinforcement of four high tensile steel wires

Recommended Fluids

Petroleum and water-glycol based fluids, lubricating oils, air and water. For air above 1.7 MPa, the hose cover must be pin-pricked.

Fitting Series



Part Number	Hose I.D.				Hose O.D.	Pressure Rating				min. bend radius	weight
	DN	Inch	Size	mm	mm	max. working pressure		min. burst pressure			
						MPa	psi	MPa	psi		
731TC-12	19	3/4	-12	19.1	32.0	42.0	6000	168.0	24000	280	1.72
731TC-16	25	1	-16	25.4	39.0	38.0	5500	152.0	22000	340	2.14
731TC-20	31	1 1/4	-20	31.8	45.0	32.0	4700	130.0	18800	460	2.96
731TC-24	38	1 1/2	-24	38.1	53.0	29.0	4200	116.0	16800	560	3.20
731TC-32	51	2	-32	50.8	68.0	25.0	3600	100.0	14400	700	5.30

Replace the hose when any deformation or damage on the hose cover are visible.
The combination of high temperature and high pressure could reduce the hose life.

787TC

No-Skive Compact Spiral™

Exceeds ISO 18752-DC

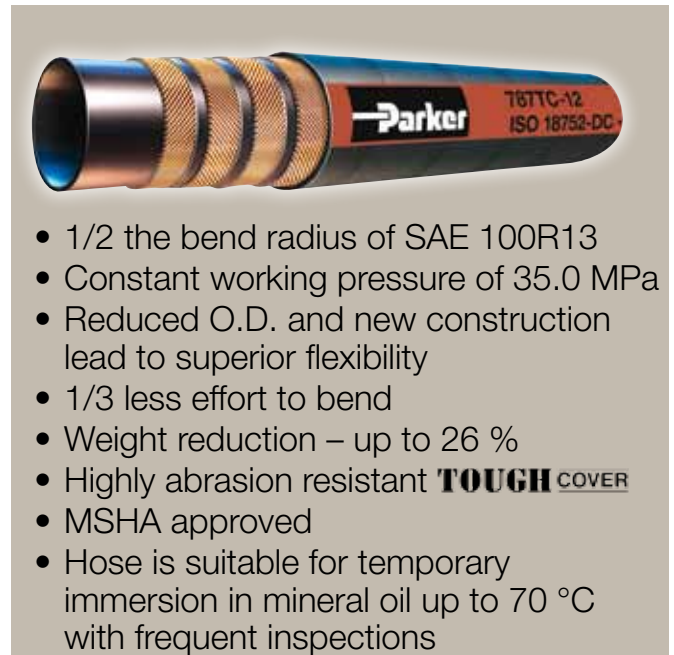

- 1/2 the bend radius of SAE 100R13
- Constant working pressure of 35.0 MPa
- Reduced O.D. and new construction lead to superior flexibility
- 1/3 less effort to bend
- Weight reduction – up to 26 %
- Highly abrasion resistant **TOUGH COVER**
- MSHA approved
- Hose is suitable for temporary immersion in mineral oil up to 70 °C with frequent inspections

Primary Applications

On- & offshore, construction, injection moulding, mining

Type Approvals

MSHA, OBAC

Applicable Specifications

SAE 100R13 – ISO 3862 Type R13 – ISO 18752-DC

Construction

- Tube: Proprietary synthetic rubber
- Reinforcement: Four or six spirals high-tensile steel wire
- Cover: High abrasion resistance
MSHA approved synthetic rubber

Recommended Fluids

Petroleum based hydraulic fluids and lubricating oils.

Temperature Range -40 °C up to +125 °C

- Exception: Air max. +70 °C
- Water max. +85 °C

Fitting Series



Part Number	Hose I.D.				Hose O.D. mm	Pressure Rating				min. bend radius mm	weight kg
	DN	Inch	Size	mm		max. working pressure		min. burst pressure			
						MPa	psi	MPa	psi		
787TC-8	12	1/2	-8	12.7	21.1	35.0	5000	140.0	20000	90	0.67
787TC-10	16	5/8	-10	15.9	23.9	35.0	5000	140.0	20000	100	0.80
787TC-12	19	3/4	-12	19.1	27.9	35.0	5000	140.0	20000	120	1.16
787TC-16	25	1	-16	25.4	35.7	35.0	5000	140.0	20000	150	1.74
787TC-20	31	1 1/4	-20	31.8	44.9	35.0	5000	140.0	20000	210	2.89
787TC-24	38	1 1/2	-24	38.1	52.8	35.0	5000	140.0	20000	255	3.96
787TC-32	51	2	-32	50.8	67.6	35.0	5000	140.0	20000	318	6.50

Replace the hose when any deformation or damage on the hose cover are visible.
 The combination of high temperature and high pressure could reduce the hose life.

797TC

No-Skive Compact Spiral™

Sizes -8 to -20 exceed ISO 18752-DC
 Sizes -24 and -32 exceed ISO 18752-CC

Primary Applications

On- & offshore, construction, injection moulding, mining

Type Approvals

MSHA

Applicable Specifications

SAE 100R15 – ISO 3862 Type R15 – ISO 18752

Construction

Tube: Proprietary synthetic rubber
 Reinforcement: Four or six spirals high-tensile steel wire
 Cover: High abrasion resistance
 MSHA approved synthetic rubber

Temperature Range -40 °C up to +125 °C

Exception: Air max. +70 °C
 Water max. +85 °C



- 1/2 the bend radius of SAE 100R15
- Constant working pressure of 42.0 MPa
- Reduced O.D. and new construction lead to superior flexibility
- 1/3 less effort to bend
- Weight reduction – up to 26 %
- Highly abrasion resistant **TOUGH COVER**
- MSHA approved
- Hose is suitable for temporary immersion in mineral oil up to 70 °C with frequent inspections

Recommended Fluids

Petroleum based hydraulic fluids and lubricating oils.

Fitting Series



Part Number	Hose I.D.				Hose O.D.	Pressure Rating				min. bend radius mm	weight kg
	DN	Inch	Size	mm	mm	max. working pressure		min. burst pressure			
						MPa	psi	MPa	psi		
797TC-8	12	1/2	-8	12.7	21.1	42.0	6000	168.0	24000	100	0.67
797TC-10	16	5/8	-10	15.9	23.9	42.0	6000	168.0	24000	115	0.80
797TC-12	19	3/4	-12	19.1	27.9	42.0	6000	168.0	24000	135	1.16
797TC-16	25	1	-16	25.4	35.7	42.0	6000	168.0	24000	165	1.74
797TC-20	31	1 1/4	-20	31.8	44.9	42.0	6000	168.0	24000	225	2.89
797TC-24	38	1 1/2	-24	38.1	52.8	42.0	6000	168.0	24000	305	3.96
797TC-32	51	2	-32	50.8	67.6	42.0	6000	168.0	24000	380	6.50

Replace the hose when any deformation or damage on the hose cover are visible.
 The combination of high temperature and high pressure could reduce the hose life.

R35TC/RS35TC-48

ParLock Multispiral

Exceeds ISO 3862 Type R13 – Parker Specifications

Primary Applications

General high pressure hydraulic applications

Type Approvals

OBAC (for R35TC-40 only)

Applicable Specifications

Exceeds ISO 3862 Type R13 – Parker Specifications

Construction

Tube: Synthetic rubber
Reinforcement: Four or six spirals high-tensile steel wire
Cover: Synthetic rubber

Temperature Range -40 °C up to +125 °C

Exception: Air max. +70 °C
Water max. +85 °C



- Interlock technology
- Reinforcement of four or six high tensile steel wires
- Constant working pressure of 35.0 MPa

Recommended Fluids

Petroleum and water-glycol based fluids, lubricating oils, air and water. For air above 1.7 MPa, the hose cover must be pin-pricked.

Fitting Series

Internal and external skiving



Part Number	Hose I.D.				Hose O.D. mm	Pressure Rating				min. bend radius mm	weight kg
	DN	Inch	Size	mm		max. working pressure		min. burst pressure			
						MPa	psi	MPa	psi		
R35TC-40	65	2 1/2	-40	63.5	84.80	35.0	5000	140.0	20000	800	9.00
RS35TC-48	75	3	-48	76.2	96.00	35.0*	5000*	140.0	20000	900	10.0
						21.0**	3040**	88.0	12750		

Replace the hose when any deformation or damage on the hose cover are visible. The combination of high temperature and high pressure could reduce the hose life.

*Static applications according to ISO 6807-D

**Dynamic hydraulic application safety factor > 4:1

881

No-Skive Suction and Return Line

SAE 100R4



- *No-Skive* hose construction
- Helical wire to prevent collapse under vacuum
- Up to +121 °C working temperature
- MSHA approved

Primary Applications

All Markets: For high temperature applications
For general applications

Type Approvals

MSHA

Construction

Tube: Synthetic rubber
Reinforcement: Two fibre spiral, one helical wire
Cover: Synthetic rubber MSHA approved

Recommended Fluids

Petroleum and water-glycol based fluids, lubricating oils, air and water.

Temperature Range -40 °C up to +121 °C

Exception: Air max. +70 °C

Water max. +85 °C

Fitting Series

Size -12 up to -16





Size -20 up to -32



Part Number	Hose I.D.				Hose O.D. mm	Pressure Rating				Vacuum kilo Pascal *1 kPa	min. bend radius mm	weight kg
	DN	Inch	Size	mm		max. working pressure		min. burst pressure				
						MPa	psi	MPa	psi			
881-12	19	3/4	-12	19.1	30.0	2.1	300	8.3	1200	95	130	0.74
881-16	25	1	-16	25.4	38.0	1.7	250	6.9	1000	95	150	0.89
881-20	31	1 1/4	-20	31.8	45.0	1.4	200	5.5	800	95	200	1.32
881-24	38	1 1/2	-24	38.1	52.0	1.0	150	4.1	600	95	250	1.65
881-32	51	2	-32	50.8	63.0	0.7	100	2.8	400	95	300	1.89



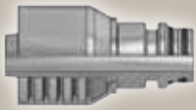
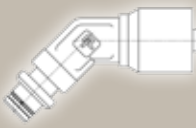

SteckO®

Page Ca-1

<p>S0 Ca-1</p>  <p>SteckO® fitting Straight</p>	<p>S7 Ca-1</p>  <p>SteckO® fitting 45° Elbow</p>	<p>SZ Ca-1</p>  <p>SteckO® fitting 90° Elbow</p>
---	--	---

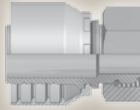
DIN – Metric

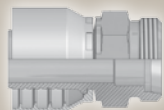
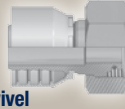
Page Ca-2 – Cb-5

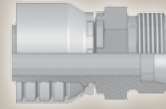
<p>CA Ca-2</p>  <p>Female Metric 24° Light Series with O-Ring Swivel – Straight ISO 12151-2-SWS-L – DKOL</p>	<p>CE Ca-2</p>  <p>Female Metric 24° Light Series with O-Ring Swivel – 45° Elbow ISO 12151-2-SWE 45°-L – DKOL 45°</p>	<p>CF Ca-3</p>  <p>Female Metric 24° Light Series with O-Ring Swivel – 90° Elbow ISO 12151-2-SWE-L – DKOL 90°</p>	<p>D0 Ca-3</p>  <p>Male Metric 24° Light Series – Rigid Straight ISO 12151-2-S-L – CEL</p>
<p>C9 Ca-4</p>  <p>Female Metric 24° – Swivel Heavy Series with O-Ring Straight ISO 12151-2-SWS-S – DKOS</p>	<p>OC Ca-4</p>  <p>Female Metric 24° – Swivel Heavy Series with O-Ring 45° Elbow ISO 12151-2-SWE 45°-S – DKOS 45°</p>	<p>D2 Ca-5</p>  <p>Male Metric 24° – Rigid Heavy Series – Straight ISO 12151-2-S-S – CES</p>	

BSP

Page Ca-6 – Ca-8

<p>92 Ca-6</p>  <p>Female BSP Parallel Pipe Swivel – Straight (60° Cone) BS5200-A – DKR</p>	<p>B1 Ca-6</p>  <p>Female BSP Parallel Pipe Swivel 45° Elbow (60° Cone) BS 5200-D – DKR 45°</p>	<p>B2 Ca-7</p>  <p>Female BSP Parallel Pipe Swivel 90° Elbow (60° Cone) BS 5200-B – DKR 90°</p>	<p>D9 Ca-7</p>  <p>Male BSP Parallel Pipe Rigid – Straight (60° Cone) BS5200 – AGR</p>
<p>B5 Ca-8</p>  <p>Female BSP Parallel Pipe Swivel Straight (Flat Seat)</p>			

SAE

Page Ca-9 – Ca-11

01

Ca-9

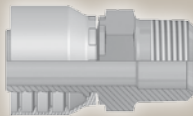

Male NPTF Pipe
Rigid – Straight
SAE J476A / J516 – AGN

03

Ca-9

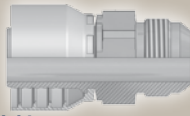

Male JIC 37° – Rigid
Straight
ISO12151-5-S – AGJ

06

Ca-10

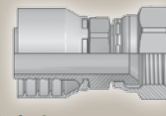

Female JIC 37° – Swivel
Straight
ISO12151-5-SWS – DKJ

37/3V

Ca-11

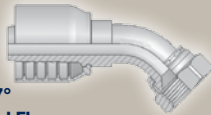

Female JIC 37°
SAE 45° – Dual Flare
Swivel Female 45° Elbow
ISO 12151-5-SWE 45° – DKJ 45°

39/3W

Ca-11

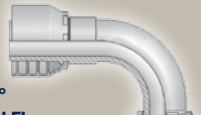

Female JIC 37°
SAE 45° – Dual Flare
Swivel Female 90° Elbow
ISO 12151-5-SWES – DKJ 90°

Flange

Page Ca-12

15

Ca-12

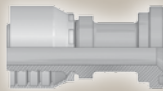

ISO 6162-1 Flange
Straight
ISO 12151-3-S-L – SFL
(21.0 MPa/ 3000 psi)

19

Ca-12



ISO 6162-1 Flange
90° Elbow
ISO 12151-3 – E-L – SFL 90°
(21.0 MPa/ 3000 psi)

S0 SteckO® fitting

Straight

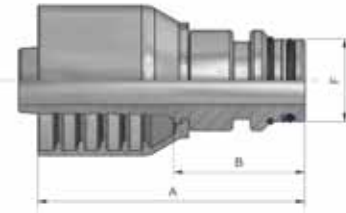

Part Number	Hose I.D.				A mm	B mm	F mm
	DN	Inch	Size	mm			
1S043-4-4	6	1/4	-4	6.4	58	34	10
1S043-6-4	6	1/4	-4	6.4	59	37	14
1S043-6-6	10	3/8	-6	9.5	65	36	14
1S043-8-8	12	1/2	-8	12.7	72	37	18
1S043-12-12	19	3/4	-12	19.1	78	38	24
1S043-16-16	25	1	-16	25.4	90	43	31
1S043-20-20	31	1 1/4	-20	31.8	95	48	38
1S043-24-24	38	1 1/2	-24	38.1	110	50	47
1S043-32-32	51	2	-32	50.8	128	63	56

S7 SteckO® fitting

45° Elbow

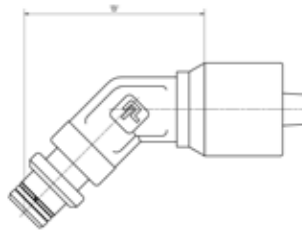

Part Number	Hose I.D.				A mm	B mm	F mm
	DN	Inch	Size	mm			
1S743-6-6	10	3/8	-6	9.5	64	35	14
1S743-8-8	12	1/2	-8	12.7	82	47	18

SZ SteckO® fitting

90° Elbow

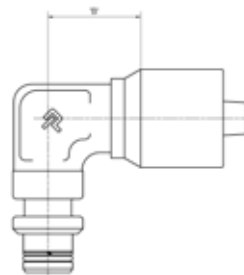

Part Number	Hose I.D.				A mm	B mm	F mm
	DN	Inch	Size	mm			
1SZ43-6-6	10	3/8	-6	9.5	44	15	14
1SZ43-8-8	12	1/2	-8	12.7	53	18	18

Approved **fitting series** for hose types:

Also available in stainless steel. Details can be found in CAT 4400.1/UK

43 CM2H CM2HP 301TC 722TC 881

CA Female Metric 24° Light Series with O-Ring Swivel – Straight

ISO 12151-2-SWS-L – DKOL

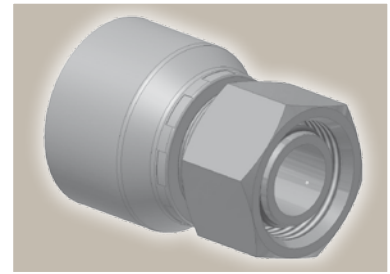
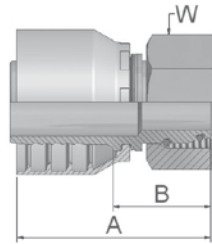

Part Number	Hose I.D.				Thread metric	Tube O.D. mm	A mm	B mm	W mm
	DN	Inch	Size	mm					
1CA43-6-4	6	1/4	-4	6.4	M12x1.5	6	44	22	14
1CA43-8-4	6	1/4	-4	6.4	M14x1.5	8	44	22	17
1CA43-10-4	6	1/4	-4	6.4	M16x1.5	10	46	22	19
1CA43-10-5	8	5/16	-5	7.9	M16x1.5	10	46	22	19
1CA43-12-5	8	5/16	-5	7.9	M18x1.5	12	46	22	22
1CA43-10-6	10	3/8	-6	9.5	M16x1.5	10	53	24	19
1CA43-12-6	10	3/8	-6	9.5	M18x1.5	12	48	19	22
1CA43-15-8	12	1/2	-8	12.7	M22x1.5	15	56	21	27
1CA43-18-10	16	5/8	-10	15.9	M26x1.5	18	61	22	32
1CA43-18-12	19	3/4	-12	19.1	M26x1.5	18	65	26	32
1CA43-22-12	19	3/4	-12	19.1	M30x2	22	63	24	36
1CA43-28-16	25	1	-16	25.4	M36x2	28	78	33	41
1CA43-35-20	31	1 1/4	-20	31.8	M45x2	35	82	35	50

CE Female Metric 24° Light Series with O-Ring Swivel – 45° Elbow

ISO 12151-2-SWE 45°-L – DKOL 45°

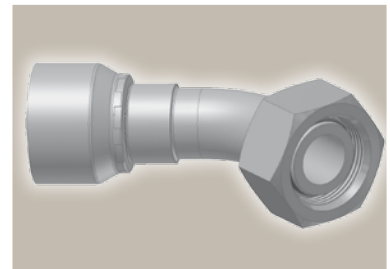
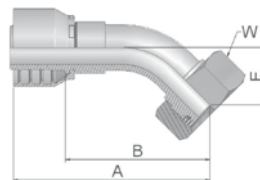

Part Number	Hose I.D.				Thread metric	Tube O.D. mm	A mm	B mm	E mm	W mm
	DN	Inch	Size	mm						
1CE43-8-4	6	1/4	-4	6.4	M14x1.5	8	59	35	16	17
1CE43-10-5	8	5/16	-5	7.9	M16x1.5	10	67	43	15	19
1CE43-12-6	10	3/8	-6	9.5	M18x1.5	12	69	39	19	22
1CE43-15-8	12	1/2	-8	12.7	M22x1.5	15	81	46	22	27
1CE43-18-10	16	5/8	-10	15.9	M26x1.5	18	89	49	23	32
1CE43-22-12	19	3/4	-12	19.1	M30x2	22	98	58	26	36

Approved **fitting series** for hose types:

Also available in stainless steel. Details can be found in CAT 4400.1/UK

43 CM2H | CM2HP | 301TC | 722TC | 881

CF **Female Metric 24°
Light Series with O-Ring
Swivel – 90° Elbow**

ISO 12151-2-SWE-L – DKOL 90°

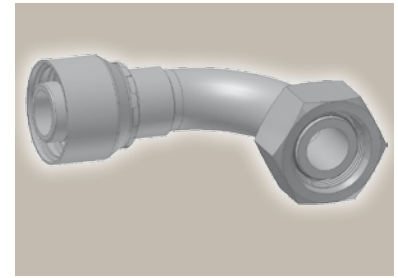
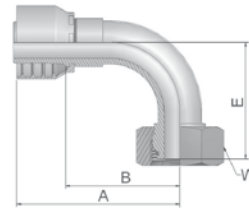

Part Number	Hose I.D.				Thread metric	Tube O.D. mm	A mm	B mm	E mm	W mm
	DN	Inch	Size	mm						
1CF43-6-4	6	1/4	-4	6.4	M12x1.5	6	55	33	33	14
1CF43-8-4	6	1/4	-4	6.4	M14x1.5	8	51	28	29	17
1CF43-10-5	8	5/16	-5	7.9	M16x1.5	10	61	37	29	19
1CF43-12-5	8	5/16	-5	7.9	M18x1.5	12	61	37	30	22
1CF43-10-6	10	3/8	-6	9.5	M16x1.5	10	65	37	35	19
1CF43-12-6	10	3/8	-6	9.5	M18x1.5	12	64	35	36	22
1CF43-15-8	12	1/2	-8	12.7	M22x1.5	15	71	37	43	27
1CF43-18-10	16	5/8	-10	15.9	M26x1.5	18	81	41	45	32
1CF43-22-12	19	3/4	-12	19.1	M30x2	22	89	49	55	36
1CF43-22-16	25	1	-16	25.4	M30x2	22	115	68	74	36
1CF43-35-20	31	1 1/4	-20	31.8	M45x2	35	130	83	79	50

DO **Male Metric 24°
Light Series – Rigid
Straight**

ISO 12151-2-S-L – CEL

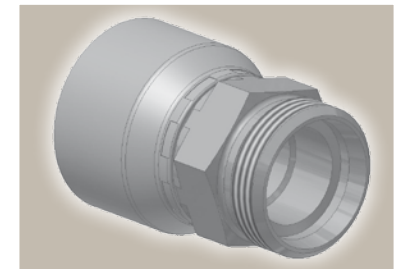
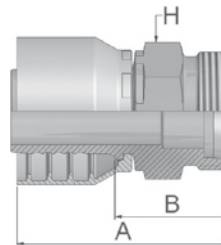

Part Number	Hose I.D.				Thread metric	Tube O.D. mm	A mm	B mm	H mm
	DN	Inch	Size	mm					
1D043-6-4	6	1/4	-4	6.4	M12x1.5	6	44	20	12
1D043-8-4	6	1/4	-4	6.4	M14x1.5	8	46	22	14
1D043-10-5	8	5/16	-5	7.9	M16x1.5	10	48	21	17
1D043-12-5	8	5/16	-5	7.9	M18x1.5	12	48	24	19
1D043-10-6	10	3/8	-6	9.5	M16x1.5	10	52	23	19
1D043-12-6	10	3/8	-6	9.5	M18x1.5	12	52	23	19
1D043-15-8	12	1/2	-8	12.7	M22x1.5	15	60	26	22
1D043-18-12	19	3/4	-12	19.1	M26x1.5	18	66	27	27
1D043-28-16	25	1	-16	25.4	M36x2	28	79	32	36

Approved **fitting series** for hose types:

Also available in stainless steel. Details can be found in CAT 4400.1/UK

43 CM2H CM2HP 301TC 722TC 881

C9 Female Metric 24° – Swivel Heavy Series with O-Ring Straight

ISO 12151-2-SWS-S – DKOS

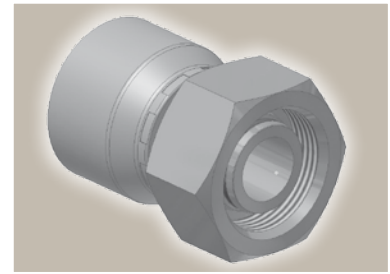
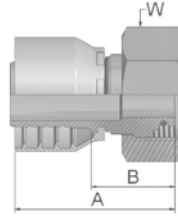

Part Number	Hose I.D.				Thread metric	Tube O.D. mm	A mm	B mm	W mm
	DN	Inch	Size	mm					
1C943-8-4	6	1/4	-4	6.4	M16x1.5	8	45	23	19
1C943-10-4	6	1/4	-4	6.4	M18x1.5	10	46	22	22
1C943-10-5	8	5/16	-5	7.9	M18x1.5	10	47	22	22
1C943-12-5	8	5/16	-5	7.9	M20x1.5	12	48	24	24
1C943-10-6	10	3/8	-6	9.5	M18x1.5	10	50	21	22
1C943-12-6	10	3/8	-6	9.5	M20x1.5	12	52	22	24
1C943-14-6	10	3/8	-6	9.5	M22x1.5	14	50	21	27
1C943-16-8	12	1/2	-8	12.7	M24x1.5	16	59	24	30
1C943-16-10	16	5/8	-10	15.9	M24x1.5	16	66	27	30
1C943-20-10	16	5/8	-10	15.9	M30x2	20	66	27	36
1C943-20-12	19	3/4	-12	19.1	M30x2	20	66	27	36
1C943-25-12	19	3/4	-12	19.1	M36x2	25	68	28	46
1C943-30-16	25	1	-16	25.4	M42x2	30	80	33	50
1C943-38-20	32	1 1/4	-20	31.8	M52x2	38	80	33	60

OC Female Metric 24° – Swivel Heavy Series with O-Ring 45° Elbow

ISO 12151-2 – SWE 45°-S – DKOS 45°

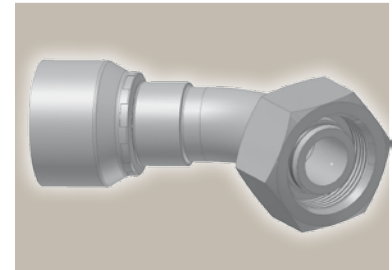
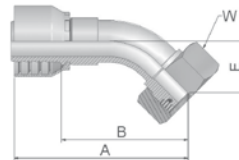

Part Number	Hose I.D.				Thread metric	Tube O.D. mm	A mm	B mm	E mm	W mm
	DN	Inch	Size	mm						
10C43-8-4	6	1/4	-4	6.4	M16x1,5	8	59	35	16	19
10C43-12-5	8	5/16	-5	7.9	M20x1,5	12	71	47	17	24
10C43-12-6	10	3/8	-6	9.5	M20x1,5	12	69	40	20	24
10C43-16-8	12	1/2	-8	12.7	M24x1,5	16	82	48	24	30
10C43-20-10	16	5/8	-10	15.9	M30x2	20	91	52	25	36
10C43-20-12	19	3/4	-12	19.1	M30x2	20	99	60	28	36
10C43-30-16	25	1	-16	25.4	M42x2	30	126	79	36	50

Approved **fitting series** for hose types:

Also available in stainless steel. Details can be found in CAT 4400.1/UK

43 CM2H | CM2HP | 301TC | 722TC | 881

D2 Male Metric 24° – Rigid Heavy Series – Straight

ISO 12151-2-S-S – CES

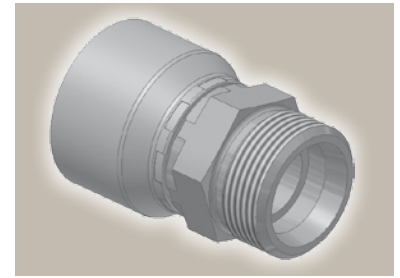
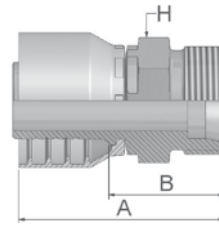

Part Number	Hose I.D.				Thread metric	Tube O.D. mm	A mm	B mm	H mm
	DN	Inch	Size	mm					
1D243-8-4	6	1/4	-4	6.4	M16x1,5	8	48	24	17
1D243-10-4	6	1/4	-4	6.4	M18x1,5	10	50	26	19
1D243-12-6	10	3/8	-6	9.5	M20x1,5	12	55	26	22
1D243-14-6	10	3/8	-6	9.5	M22x1,5	14	55	25	22
1D243-16-8	12	1/2	-8	12.7	M24x1,5	16	62	28	24
1D243-20-10	16	5/8	-10	15.9	M30x2	20	72	33	30
1D243-30-16	25	1	-16	25.4	M42x2	30	85	40	46

Approved **fitting series** for hose types:

Also available in stainless steel. Details can be found in CAT 4400.1/UK

43 CM2H CM2HP 301TC 722TC 881

92 Female BSP Parallel Pipe Swivel – Straight (60° Cone)

BS5200-A – DKR

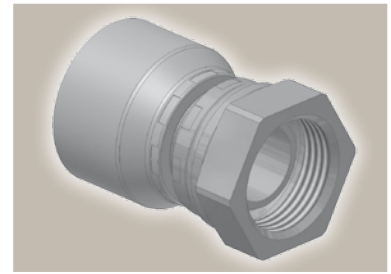
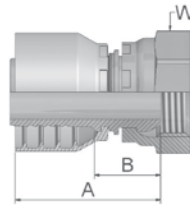

Part Number	Hose I.D.				Thread BSP	A mm	B mm	W mm
	DN	Inch	Size	mm				
19243-4-4	6	1/4	-4	6.4	1/4x19	43	19	19
19243-6-5	8	5/16	-5	7.9	3/8x19	44	20	22
19243-6-6	10	3/8	-6	9.5	3/8x19	49	20	22
19243-8-6	10	3/8	-6	9.5	1/2x14	51	22	27
19243-8-8	12	1/2	-8	12.7	1/2x14	57	22	27
19243-12-10	16	5/8	-10	15.9	3/4x14	61	22	32
19243-12-12	19	3/4	-12	19.1	3/4x14	61	22	32
19243-16-16	25	1	-16	25.4	1x11	72	25	41
19243-20-20	31	1 1/4	-20	31.8	1-1/4x11	79	32	50

B1 Female BSP Parallel Pipe Swivel 45° Elbow (60° Cone)

BS 5200-D – DKR 45°

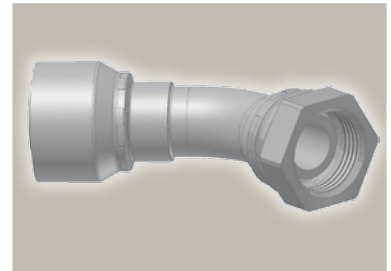
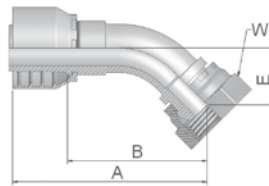

Part Number	Hose I.D.				Thread BSP	A mm	B mm	E mm	W mm
	DN	Inch	Size	mm					
1B143-8-8	12	1/2	-8	12.7	1/2x14	79	45	20	27

Approved **fitting series** for hose types:

Also available in stainless steel. Details can be found in CAT 4400.1/UK

43 CM2H | CM2HP | 301TC | 722TC | 881

B2 Female BSP Parallel Pipe Swivel 90° Elbow (60° Cone)

BS 5200-B – DKR 90°

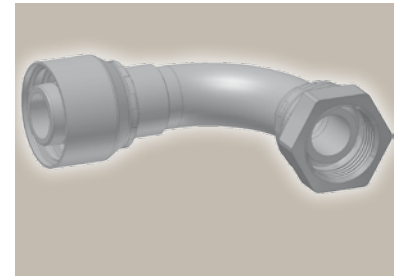
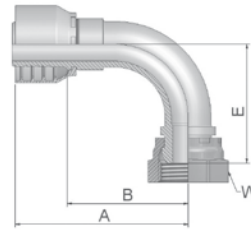

Part Number	Hose I.D.				Thread BSP	A mm	B mm	E mm	W mm
	DN	Inch	Size	mm					
1B243-4-4	6	1/4	-4	6.4	1/4x19	50	26	28	19
1B243-6-6	10	3/8	-6	9.5	3/8x19	66	37	33	22
1B243-8-6	10	3/8	-6	9.5	1/2x14	66	37	35	27
1B243-8-8	12	1/2	-8	12.7	1/2x14	74	39	40	27
1B243-10-10	16	5/8	-10	15.9	5/8x14	81	41	46	30
1B243-12-12	19	3/4	-12	19.1	3/4x14	82	43	45	32
1B243-16-16	25	1	-16	25.4	1x11	116	69	69	41
1B243-20-20	31	1 1/4	-20	31.8	1-1/4x11	129	82	80	50

D9 Male BSP Parallel Pipe Rigid – Straight (60° Cone)

BS5200 – AGR

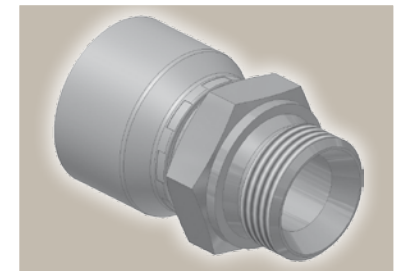
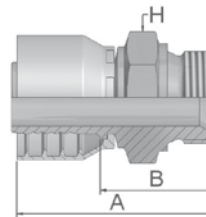

Part Number	Hose I.D.				Thread BSP	A mm	B mm	H mm
	DN	Inch	Size	mm				
1D943-4-4	6	1/4	-4	6.4	1/4x19	49	27	19
1D943-6-6	10	3/8	-6	9.5	3/8x19	57	28	22
1D943-8-6	10	3/8	-6	9.5	1/2x14	60	31	27
1D943-8-8	12	1/2	-8	12.7	1/2x14	64	30	27
1D943-16-16	25	1	-16	25.4	1x11	85	40	41



Approved **fitting series** for hose types:

Also available in stainless steel. Details can be found in CAT 4400.1/UK

43 CM2H CM2HP 301TC 722TC 881

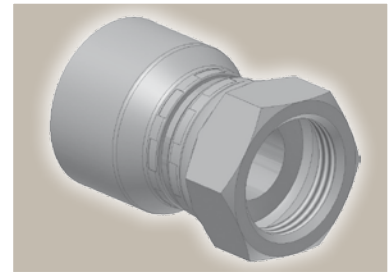
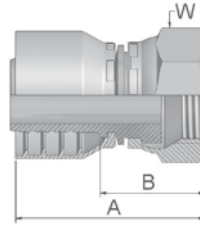
B5 Female BSP Parallel Pipe
Swivel
Straight (Flat Seat)



Part Number	 Hose I.D.				 Thread BSP	A mm	B mm	 W mm
	DN	Inch	Size	mm				
1B543-8-6	10	3/8	-6	9.5	1/2x14	48	19	27
1B543-8-8	12	1/2	-8	12.7	1/2x14	54	19	27

Approved **fitting series** for hose types:

Also available in stainless steel. Details can be found in CAT 4400.1/UK

43 CM2H | CM2HP | 301TC | 722TC | 881

01

Male NPTF Pipe Rigid – Straight

SAE J476A/ J516 – AGN

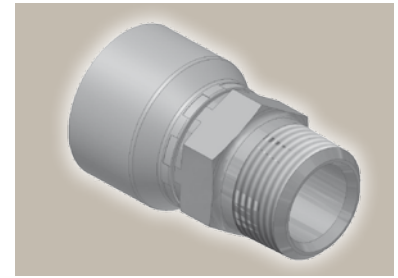
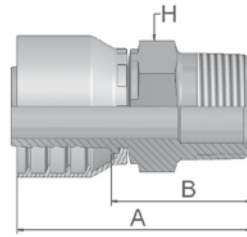

Part Number	Hose I.D.				Thread NPTF	A mm	B mm	H mm
	DN	Inch	Size	mm				
10143-4-4-SM	6	1/4	-4	6.4	1/4x18	53	29	14
10143-6-4-SM	6	1/4	-4	6.4	3/8x18	55	31	19
10143-6-6-SM	10	3/8	-6	9.5	3/8x18	60	31	19
10143-8-6-SM	10	3/8	-6	9.5	1/2x14	61	32	22
10143-8-8-SM	12	1/2	-8	12.7	1/2x14	67	35	22
10143-12-12-SM	19	3/4	-12	19.1	3/4x14	79	39	27
10143-16-16-SM	25	1	-16	25.4	1x11-1/2	92	46	36

03

Male JIC 37° – Rigid Straight

ISO12151-5-S – AGJ

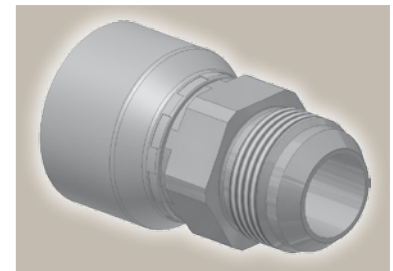
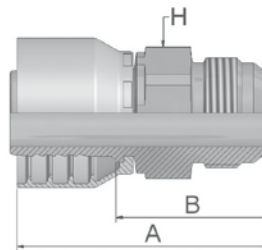

Part Number	Hose I.D.				Thread UNF	A mm	B mm	H mm
	DN	Inch	Size	mm				
10343-4-4-SM	6	1/4	-4	6.4	7/16x20	52	29	14
10343-6-4-SM	6	1/4	-4	6.4	9/16x18	55	31	19
10343-6-6-SM	10	3/8	-6	9.5	9/16x18	60	31	19
10343-8-6-SM	10	3/8	-6	9.5	3/4x16	59	29	19
10343-8-8-SM	12	1/2	-8	12.7	3/4x16	68	33	22
10343-10-8-SM	12	1/2	-8	12.7	7/8x14	67	32	24
10343-10-10-SM	16	5/8	-10	15.9	7/8x14	76	41	24
10343-12-12-SM	19	3/4	-12	19.1	1-1/16x12	82	42	27

Approved **fitting series** for hose types:

Also available in stainless steel. Details can be found in CAT 4400.1/UK

43 CM2H CM2HP 301TC 722TC 881

06 Female JIC 37° – Swivel Straight

ISO12151-5-SWS – DKJ

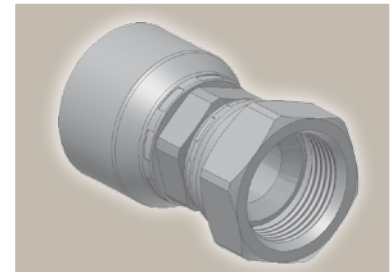
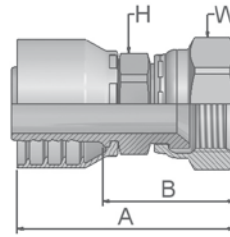

Part Number	Hose I.D.				Thread UNF	A mm	B mm	H mm	W mm
	DN	Inch	Size	mm					
10643-4-4-SM	6	1/4	-4	6.4	7/16x20	52	29	14	17
10643-5-4-SM	6	1/4	-4	6.4	1/2x20	53	30	14	17
10643-6-4-SM	6	1/4	-4	6.4	9/16x18	55	31	14	19
10643-5-5	8	5/16	-5	7.9	1/2x20	54	31	14	17
10643-6-5-SM	8	5/16	-5	7.9	9/16x18	53	32	17	19
10643-6-6-SM	10	3/8	-6	9.5	9/16x18	58	29	17	19
10643-8-6-SM	10	3/8	-6	9.5	3/4x16	61	32	19	22
10643-10-6-SM	10	3/8	-6	9.5	7/8x14	64	35	22	27
10643-8-8-SM	12	1/2	-8	12.7	3/4x16	72	32	22	22
10643-10-8-SM	12	1/2	-8	12.7	7/8x14	72	38	22	27
10643-12-8-SM	12	1/2	-8	12.7	7/8x14	78	35	24	27
10643-10-10-SM	16	5/8	-10	15.9	7/8x14	74	35	24	27
10643-12-10-SM	16	5/8	-10	15.9	1-1/16x12	78	41	27	32
10643-12-12-SM	19	3/4	-12	19.1	1-1/16x12	80	41	27	32
10643-16-16-SM	25	1	-16	25.4	1-5/16x12	94	47	36	41
10643-20-16-SM	25	1	-16	25.4	1-5/8x12	96	52	41	50
10643-20-20-SM	31	1 1/4	-20	31.8	1-5/8x12	100	53	46	50

Approved **fitting series** for hose types:

Also available in stainless steel. Details can be found in CAT 4400.1/UK

43 CM2H | CM2HP | 301TC | 722TC | 881

37/3V Female JIC 37° SAE 45° – Dual Flare Swivel Female 45° Elbow

ISO 12151-5-SWE 45° – DKJ 45°

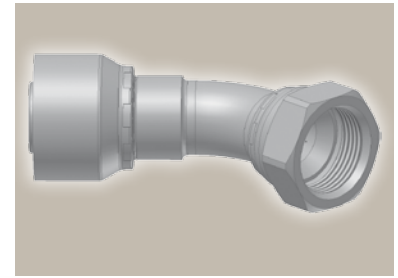
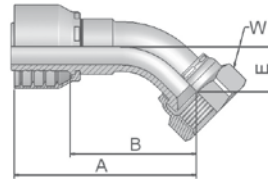

Part Number	Hose I.D.				Thread UNF	A mm	B mm	E mm	W mm
	DN	Inch	Size	mm					
13743-4-4-SM	6	1/4	-4	6.4	7/16x20	53	29	10	17
13743-5-4-SM	6	1/4	-4	6.4	1/2x20	57	33	9	17
13743-6-4-SM	6	1/4	-4	6.4	9/16x18	55	31	11	19
13743-6-6-SM	10	3/8	-6	9.5	9/16x18	60	31	10	19
13V43-8-6-SM	10	3/8	-6	9.5	3/4x16	70	41	14	22
13743-8-8-SM	12	1/2	-8	12.7	3/4x16	73	38	14	22
13743-10-8-SM	12	1/2	-8	12.7	7/8x14	78	43	17	27
13743-10-10-SM	16	5/8	-10	15.9	7/8x14	83	44	17	27
13743-12-12-SM	19	3/4	-12	19.1	1-1/16x12	93	54	22	32
13743-16-16-SM	25	1	-16	25.4	1-5/16x12	111	66	24	41

39/3W Female JIC 37° SAE 45° – Dual Flare Swivel Female 90° Elbow

ISO 12151-5-SWES – DKJ 90°

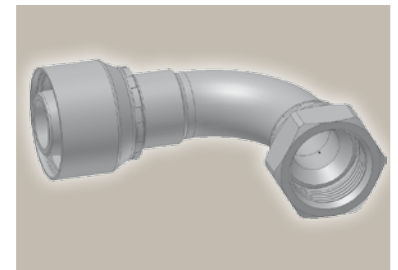
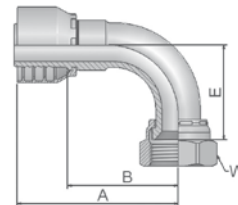

Part Number	Hose I.D.				Thread UNF	A mm	B mm	E mm	W mm
	DN	Inch	Size	mm					
13943-4-4-SM	6	1/4	-4	6.4	7/16-20	51	24	21	17
13943-5-4-SM	6	1/4	-4	6.4	1/2x20	57	34	21	17
13943-6-4-SM	6	1/4	-4	6.4	9/16x18	51	27	23	19
13943-6-6-SM	10	3/8	-6	9.5	9/16x18	57	28	23	19
13W43-8-6-SM	10	3/8	-6	9.5	3/4x16	64	35	29	22
13943-8-8-SM	12	1/2	-8	12.7	3/4x16	66	32	29	22
13943-10-8-SM	12	1/2	-8	12.7	7/8x14	80	40	33	27
13943-10-10-SM	16	5/8	-10	15.9	1-1/16x12	89	50	48	32
13943-12-12-SM	19	3/4	-12	19.1	1-5/16x12	109	64	55	41
13943-16-16-SM	25	1	-16	25.4	1-5/16x12	109	64	55	41

Approved fitting series for hose types:



Also available in stainless steel. Details can be found in CAT 4400.1/UK

43 CM2H CM2HP 301TC 722TC 881

15 ISO 6162-1 Flange Straight

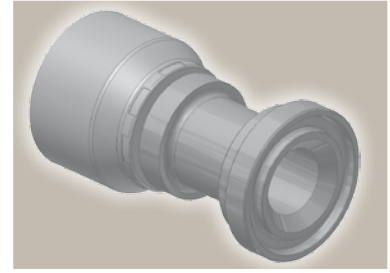
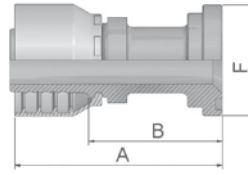
ISO 12151-3-S-L – SFL
(21.0 MPa/ 3000 psi)





Part Number	 Hose I.D.				 Flange	A	B	F
	DN	Inch	Size	mm	Inch	mm	mm	mm
11543-20-20	31	1 1/4	-20	31.8	1-1/4	120	72	51

19 ISO 6162-1 Flange 90° Elbow

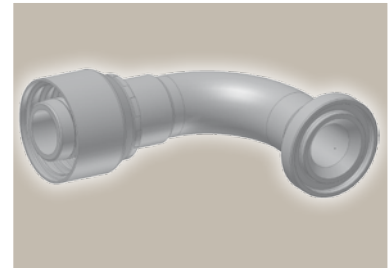
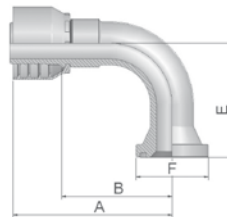
ISO 12151-3 – E- L – SFL 90°
(21.0 MPa/ 3000 psi)



Part Number	 Hose I.D.				 Flange	A	B	E	F
	DN	Inch	Size	mm	Inch	mm	mm	mm	mm
11943-20-16-1P	25	1	-16	25.4	1-1/2	113	68	62	60

Approved **fitting series** for hose types:

Also available in stainless steel. Details can be found in CAT 4400.1/UK

43 CM2H | CM2HP | 301TC | 722TC | 881





SteckO®

Page Cb-1

<p>S0 Cb-1</p>  <p>SteckO® fitting Straight</p>	<p>2piece 48 Series</p> <p>10048 Cb-1</p> <p>No-Skive shell for hose CM2H</p>  <p>for use with adjustable crimpers only</p>
---	---

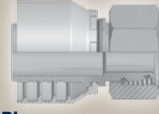

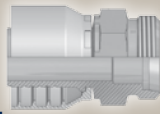
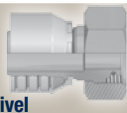

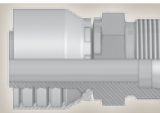
DIN – Metric

Page Cb-2 – Cb-9

<p>CA Cb-2</p>  <p>Female Metric 24° Light Series with O-Ring Swivel – Straight ISO 12151-2-SWS-L – DKOL</p>	<p>CE Cb-3</p>  <p>Female Metric 24° Light Series with O-Ring Swivel – 45° Elbow ISO 12151-2-SWE 45°-L – DKOL 45°</p>	<p>CF Cb-4</p>  <p>Female Metric 24° Light Series with O-Ring Swivel – 90° Elbow ISO 12151-2-SWE-L – DKOL 90°</p>	<p>D0 Cb-5</p>  <p>Male Metric 24° Light Series – Rigid Straight ISO 12151-2-S-L – CEL</p>
<p>C9 Cb-6</p>  <p>Female Metric 24° – Swivel Heavy Series with O-Ring Straight ISO 12151-2-SWS-S – DKOS</p>	<p>0C Cb-7</p>  <p>Female Metric 24° – Swivel Heavy Series with O-Ring 45° Elbow ISO 12151-2 – SWE 45°-S – DKOS 45°</p>	<p>1C Cb-8</p>  <p>Female Metric 24° – Swivel Heavy Series with O-Ring 90° Elbow ISO 12151-2-SWE-S – DKOS 90°</p>	<p>D2 Cb-9</p>  <p>Male Metric 24° – Rigid Heavy Series – Straight ISO 12151-2-S-S – CES</p>

BSP

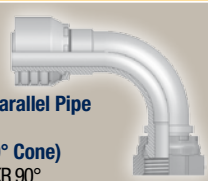
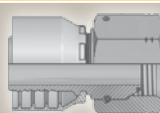
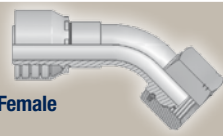
Page Cb-10 – Cb-16

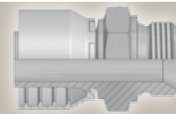
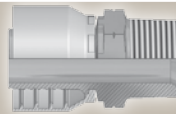
<p>92 Cb-10</p>  <p>Female BSP Parallel Pipe Swivel – Straight (60° Cone) BS5200-A – DKR</p>	<p>B1 Cb-11</p>  <p>Female BSP Parallel Pipe Swivel 45° Elbow (60° Cone) BS 5200-D – DKR 45°</p>	<p>B2 Cb-12</p>  <p>Female BSP Parallel Pipe Swivel 90° Elbow (60° Cone) BS 5200-B – DKR 90°</p>	<p>EA Cb-13</p>  <p>BSP Swivel Female with O-Ring (60° Cone) BS 5200 – ISO 12151-6 – DKOR</p>
<p>EB Cb-13</p>  <p>BSP Swivel Female with O-Ring 45° Elbow (60° Cone) BS 5200 – ISO 12151-6 – DKOR 45°</p>	<p>EC Cb-14</p>  <p>BSP Swivel Female with O-Ring 90° Elbow (60° Cone) BS 5200 – ISO 12151-6 – DKOR 90°</p>	<p>D9 Cb-15</p>  <p>Male BSP Parallel Pipe Rigid – Straight (60° Cone) BS5200 – AGR</p>	<p>91 Cb-16</p>  <p>Male BSP Taper Pipe – Rigid Straight BS5200 – AGR-K</p>

SAE

Page Cb-17 – Cb-22

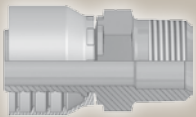
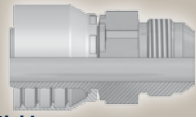
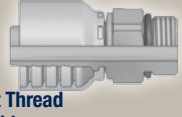
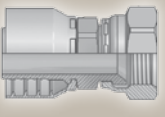
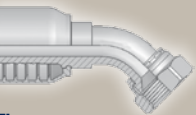
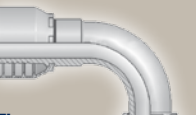
<p>01 Cb-17</p>  <p>Male NPTF Pipe Rigid – Straight SAE J476A / J516 – AGN</p>	<p>03 Cb-18</p>  <p>Male JIC 37° – Rigid Straight ISO12151-5-S – AGJ</p>	<p>05 Cb-19</p>  <p>Male SAE Straight Thread with O-Ring – Rigid Straight ISO 11926 – SAE J516</p>	<p>06/68 Cb-20</p>  <p>Female – JIC 37° SAE 45° Dual Flare Swivel – Straight ISO12151-5-SWS – DKJ</p>
<p>37/3V Cb-21</p>  <p>Female JIC 37° SAE 45° – Dual Flare Swivel Female 45° Elbow ISO 12151-5-SWE 45° – DKJ 45°</p>	<p>39/3W Cb-22</p>  <p>Female JIC 37° SAE 45° – Dual Flare Swivel Female 90° Elbow ISO 12151-5-SWES – DKJ 90°</p>		

Flange

Page Cc-28 – Cc-32

<p>15 Cc-28</p>  <p>ISO 6162-1 Flange Straight ISO 12151-3-S-L – SFL (21.0 MPa/ 3000 psi)</p>	<p>17 Cb-24</p>  <p>ISO 6162-1 Flange 45° Elbow ISO 12151-3 – E45 – L – SFL 45° (21.0 MPa/ 3000 psi)</p>	<p>19 Cb-25</p>  <p>ISO 6162-1 Flange 90° Elbow ISO 12151-3 – E-L – SFL 90° (21.0 MPa/ 3000 psi)</p>
<p>6A Cc-31</p>  <p>ISO 6162-2 Flange Straight ISO 12151-3-S-S – SFS (42.0 MPa/ 6000 psi)</p>	<p>6F Cc-31</p>  <p>ISO 6162-2 Flange 45° Elbow – Heavy Series ISO 12151-3 – E45-S – SFS 45° (42.0 MPa/ 6000 psi)</p>	<p>6N Cc-32</p>  <p>ISO 6162-2 Flange 90° Elbow ISO 12151-3 – E-S – SFS 90° (42.0 MPa/ 6000 psi)</p>

UPTC Universal push-to-connect

Page Cb-28 – Cb-29

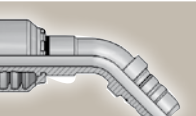
<p>EN Cb-28</p>  <p>UPTC – Male Straight</p>	<p>EU Cb-28</p>  <p>UPTC – Male 45° Elbow</p>	<p>ET Cb-29</p>  <p>UPTC – Male 90° Elbow</p>
--	---	--

S0 **Stecko® fitting**
Straight

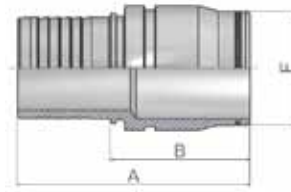

Part Number	 Hose I.D.				A	B	F
	DN	Inch	Size	mm	mm	mm	mm
KS047-40-40*	63	2 1/2	-40	63.5	142	80	79
KS047-48-48*	76	3	-48	76.2	175	105	86

* 2piece 48 Series

10048 **No-Skive shell**
for hose CM2H

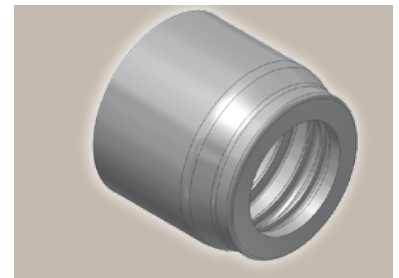
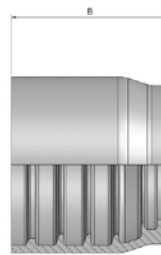

Part Number	 Hose I.D.				B
	DN	Inch	Size	mm	mm
10048-40**	63	2 1/2	-40	63.5	67
10048-48**	76	3	-48	76.2	75

**for use with adjustable crimpers only

Approved **fitting series** for hose types:

Also available in stainless steel. Details can be found in CAT 4400.1/UK

48 301TC 462TC 436 881

CA **Female Metric 24°
Light Series with O-Ring
Swivel – Straight**

ISO 12151-2-SWS-L – DKOL

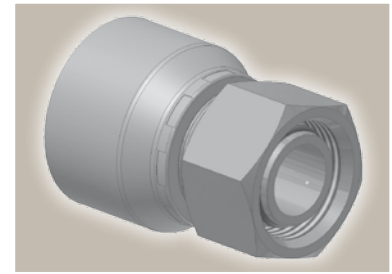
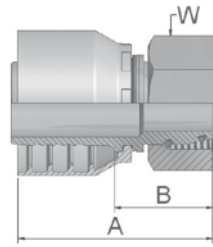

Part Number	Hose I.D.				Thread metric	Tube O.D. mm	A mm	B mm	W mm
	DN	Inch	Size	mm					
1CA48-6-4	6	1/4	-4	6.4	M12x1,5	6	46	22	14
1CA48-8-4	6	1/4	-4	6.4	M14x1,5	8	46	22	17
1CA48-10-4	6	1/4	-4	6.4	M16x1,5	10	46	22	19
1CA48-12-4	6	1/4	-4	6.4	M18x1,5	12	46	22	22
1CA48-8-5	8	5/16	-5	7.9	M14x1,5	8	50	26	17
1CA48-10-5	8	5/16	-5	7.9	M16x1,5	10	46	22	19
1CA48-12-5	8	5/16	-5	7.9	M18x1,5	12	46	22	22
1CA48-8-6	10	3/8	-6	9.5	M14x1,5	8	49	26	17
1CA48-10-6	10	3/8	-6	9.5	M16x1,5	10	46	23	19
1CA48-12-6	10	3/8	-6	9.5	M18x1,5	12	46	23	22
1CA48-15-6	10	3/8	-6	9.5	M22x1,5	15	47	24	27
1CA48-18-6	10	3/8	-6	9.5	M26x1,5	18	50	28	32
1CA48-12-8	12	1/2	-8	12.7	M18x1,5	12	50	26	22
1CA48-15-8	12	1/2	-8	12.7	M22x1,5	15	50	26	27
1CA48-18-8	12	1/2	-8	12.7	M26x1,5	18	49	25	32
1CA48-15-10	16	5/8	-10	15.9	M22x1,5	15	54	29	27
1CA48-18-10	16	5/8	-10	15.9	M26x1,5	18	50	25	32
1CA48-22-10	16	5/8	-10	15.9	M30x2	22	58	33	36
1CA48-18-12	19	3/4	-12	19.1	M26x1,5	18	51	25	32
1CA48-22-12	19	3/4	-12	19.1	M30x2	22	56	30	36
1CA48-28-12	19	3/4	-12	19.1	M36x2	28	61	35	41
1CA48-22-16	25	1	-16	25.4	M30x2	22	60	30	36
1CA48-28-16	25	1	-16	25.4	M36x2	28	63	33	41
1CA48-35-16	25	1	-16	25.4	M45x2	35	63	33	50
1CA48-28-20	31	1 1/4	-20	31.8	M36x2	28	81	34	41
1CA48-35-20	31	1 1/4	-20	31.8	M45x2	35	82	35	50
1CA48-42-24	38	1 1/2	-24	38.1	M52x2	42	77	39	60

Hose fittings are delivered with ozone resistant Nitrile (NBR) O-ring as a standard version. Working temperature from -40 °C up to +105 °C.
Hose fittings with special O-rings (Viton or EPDM) available on request. For O-ring dimensions and part-numbers see Section F.

Approved **fitting series** for hose types:

Also available in stainless steel. Details can be found in CAT 4400.1/UK

48 301TC 462TC 436 881

CE

**Female Metric 24°
Light Series with O-Ring
Swivel – 45° Elbow**

ISO 12151-2-SWE 45°-L – DKOL 45°

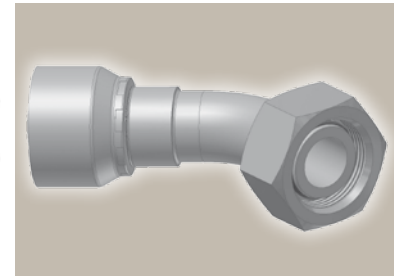
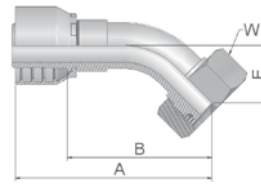

Part Number	Hose I.D.			Thread metric	Tube O.D. mm	A mm	B mm	E mm	W mm	
	DN	Inch	Size							
1CE48-6-4	6	1/4	-4	6.4	M12x1.5	6	70	45	19	14
1CE48-8-4	6	1/4	-4	6.4	M14x1.5	8	59	35	16	17
1CE48-10-4	6	1/4	-4	6.4	M16x1.5	10	59	35	16	19
1CE48-12-4	6	1/4	-4	6.4	M18x1.5	12	59	36	16	22
1CE48-8-5	8	5/16	-5	7.9	M14x1.5	8	64	40	19	17
1CE48-10-5	8	5/16	-5	7.9	M16x1.5	10	67	43	15	19
1CE48-12-5	8	5/16	-5	7.9	M18x1.5	12	61	37	16	22
1CE48-10-6	10	3/8	-6	9.5	M16x1.5	10	68	45	20	19
1CE48-12-6	10	3/8	-6	9.5	M18x1.5	12	68	45	19	22
1CE48-15-6	10	3/8	-6	9.5	M22x1.5	15	68	45	19	27
1CE48-12-8	12	1/2	-8	12.7	M18x1.5	12	74	51	23	22
1CE48-15-8	12	1/2	-8	12.7	M22x1.5	15	71	47	22	27
1CE48-18-8	12	1/2	-8	12.7	M26x1.5	18	71	47	22	32
1CE48-15-10	16	5/8	-10	15.9	M22x1.5	15	79	54	26	27
1CE48-18-10	16	5/8	-10	15.9	M26x1.5	18	76	50	23	32
1CE48-18-12	19	3/4	-12	19.1	M26x1.5	18	90	64	27	32
1CE48-22-12	19	3/4	-12	19.1	M30x2	22	88	62	26	36
1CE48-28-12	19	3/4	-12	19.1	M36x2	28	90	64	28	41
1CE48-22-16	25	1	-16	25.4	M30x2	22	112	82	35	36
1CE48-28-16	25	1	-16	25.4	M36x2	28	113	83	33	41
1CE48-35-20	31	1 1/4	-20	31.8	M45x2	35	141	94	38	50
1CE48-42-24	38	1 1/2	-24	38.1	M52x2	42	155	117	49	60

Hose fittings are delivered with ozone resistant Nitrile (NBR) O-ring as a standard version. Working temperature from -40 °C up to +105 °C.
Hose fittings with special O-rings (Viton or EPDM) available on request. For O-ring dimensions and part-numbers see Section F.

Approved **fitting series** for hose types:

Also available in stainless steel. Details can be found in CAT 4400.1/UK

48 301TC 462TC 436 881

CF **Female Metric 24°
Light Series with O-Ring
Swivel – 90° Elbow**

ISO 12151-2-SWE-L – DKOL 90°

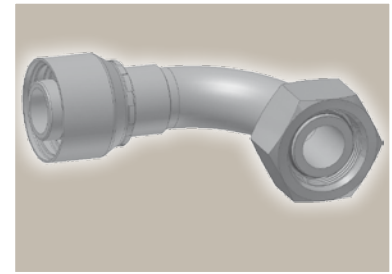
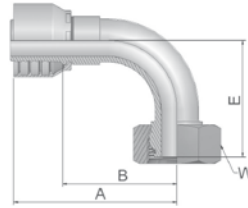

Part Number	Hose I.D.				Thread metric	Tube O.D. mm	A mm	B mm	E mm	W mm
	DN	Inch	Size	mm						
1CF48-6-4	6	1/4	-4	6.4	M12x1.5	6	57	33	33	14
1CF48-8-4	6	1/4	-4	6.4	M14x1.5	8	51	28	29	17
1CF48-10-4	6	1/4	-4	6.4	M16x1.5	10	52	28	29	19
1CF48-12-4	6	1/4	-4	6.4	M18x1.5	12	53	26	29	22
1CF48-8-5	8	5/16	-5	7.9	M14x1.5	8	62	38	34	17
1CF48-10-5	8	5/16	-5	7.9	M16x1.5	10	61	37	29	19
1CF48-12-5	8	5/16	-5	7.9	M18x1.5	12	61	37	30	22
1CF48-10-6	10	3/8	-6	9.5	M16x1.5	10	60	37	37	19
1CF48-12-6	10	3/8	-6	9.5	M18x1.5	12	58	35	36	22
1CF48-15-6	10	3/8	-6	9.5	M22x1.5	15	58	35	36	27
1CF48-12-8	12	1/2	-8	12.7	M18x1.5	12	63	39	45	22
1CF48-15-8	12	1/2	-8	12.7	M22x1.5	15	61	37	43	27
1CF48-18-8	12	1/2	-8	12.7	M26x1.5	18	65	41	43	32
1CF48-15-10	16	5/8	-10	15.9	M22x1.5	15	67	42	50	27
1CF48-18-10	16	5/8	-10	15.9	M26x1.5	18	66	41	45	32
1CF48-22-10	16	5/8	-10	15.9	M30x2	22	71	46	47	36
1CF48-18-12	19	3/4	-12	19.1	M26x1.5	18	80	54	56	32
1CF48-22-12	19	3/4	-12	19.1	M30x2	22	80	54	55	36
1CF48-28-12	19	3/4	-12	19.1	M36x2	28	80	54	57	41
1CF48-22-16	25	1	-16	25.4	M30x2	22	102	72	74	36
1CF48-28-16	25	1	-16	25.4	M36x2	28	101	72	71	41
1CF48-28-20	31	1 1/4	-20	31.8	M36x2	28	129	82	81	41
1CF48-35-20	31	1 1/4	-20	31.8	M45x2	35	130	83	79	50
1CF48-42-24	38	1 1/2	-24	38.1	M52x2	42	139	101	101	60

Hose fittings are delivered with ozone resistant Nitrile (NBR) O-ring as a standard version. Working temperature from -40 °C up to +105 °C.
Hose fittings with special O-rings (Viton or EPDM) available on request. For O-ring dimensions and part-numbers see Section F.

Approved **fitting series** for hose types:

Also available in stainless steel. Details can be found in CAT 4400.1/UK

48 301TC | 462TC | 436 | 881

D0

**Male Metric 24°
Light Series – Rigid
Straight**

ISO 12151-2-S-L – CEL

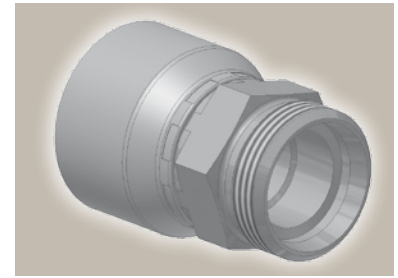
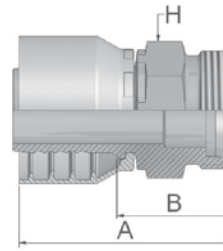

Part Number	Hose I.D.				Thread metric	Tube O.D. mm	A mm	B mm	H mm
	DN	Inch	Size	mm					
1D048-6-4	6	1/4	-4	6.4	M12x1.5	6	44	20	12
1D048-8-4	6	1/4	-4	6.4	M14x1.5	8	46	22	14
1D048-10-4	6	1/4	-4	6.4	M16x1.5	10	48	24	17
1D048-12-4	6	1/4	-4	6.4	M18x1.5	12	48	24	19
1D048-8-5	8	5/16	-5	7.9	M14x1.5	8	44	20	14
1D048-10-5	8	5/16	-5	7.9	M16x1.5	10	48	24	17
1D048-12-5	8	5/16	-5	7.9	M18x1.5	12	48	24	19
1D048-10-6	10	3/8	-6	9.5	M16x1.5	10	47	24	17
1D048-12-6	10	3/8	-6	9.5	M18x1.5	12	47	24	19
1D048-15-6	10	3/8	-6	9.5	M22x1.5	15	49	26	22
1D046-12-8	12	1/2	-8	12.7	M18x1.5	12	47	23	19
1D048-15-8	12	1/2	-8	12.7	M22x1.5	15	50	26	22
1D048-18-8	12	1/2	-8	12.7	M26x1.5	18	53	29	27
1D048-15-10	16	5/8	-10	15.9	M22x1.5	15	57	29	27
1D048-18-10	16	5/8	-10	15.9	M26x1.5	18	54	29	27
1D048-18-12	19	3/4	-12	19.1	M26x1.5	18	55	29	27
1D048-22-12	19	3/4	-12	19.1	M30x2	22	59	33	30
1D048-28-12	19	3/4	-12	19.1	M36x2	28	60	34	36
1D048-28-16	25	1	-16	25.4	M36x2	28	65	35	36
1D048-35-20	31	1 1/4	-20	31.8	M45x2	35	85	38	46
1D048-42-24	38	1 1/2	-24	38.1	M52x2	42	77	39	55

Approved **fitting series** for hose types:

Also available in stainless steel. Details can be found in CAT 4400.1/UK

48 301TC 462TC 436 881

C9 Female Metric 24° – Swivel Heavy Series with O-Ring Straight

ISO 12151-2-SWS-S – DKOS

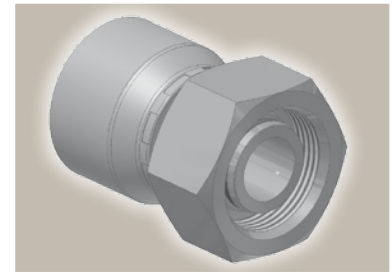
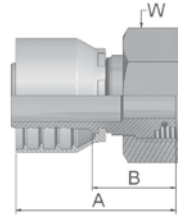

Part Number	Hose I.D.				Thread metric	Tube O.D. mm	A mm	B mm	W mm
	DN	Inch	Size	mm					
1C948-6-4	6	1/4	-4	6.4	M14x1.5	6	49	26	17
1C948-8-4	6	1/4	-4	6.4	M16x1.5	8	47	23	19
1C948-10-4	6	1/4	-4	6.4	M18x1.5	10	46	22	22
1C948-12-4	6	1/4	-4	6.4	M20x1.5	12	47	24	24
1C948-14-4	6	1/4	-4	6.4	M22x1.5	14	48	24	27
1C948-8-5	8	5/16	-5	7.9	M16x1.5	8	46	23	19
1C948-10-5	8	5/16	-5	7.9	M18x1.5	10	46	22	22
1C948-12-5	8	5/16	-5	7.9	M20x1.5	12	48	24	24
1C948-14-5	8	5/16	-5	7.9	M22x1.5	14	48	24	27
1C948-16-5	8	5/16	-5	7.9	M24x1.5	16	52	28	30
1C948-8-6	10	3/8	-6	9.5	M16x1.5	8	49	26	19
1C948-10-6	10	3/8	-6	9.5	M18x1.5	10	45	23	22
1C948-12-6	10	3/8	-6	9.5	M20x1.5	12	47	24	24
1C948-14-6	10	3/8	-6	9.5	M22x1.5	14	47	24	27
1C948-16-6	10	3/8	-6	9.5	M24x1.5	16	50	28	30
1C948-12-8	12	1/2	-8	12.7	M20x1.5	12	51	28	24
1C948-14-8	12	1/2	-8	12.7	M22x1.5	14	48	24	27
1C948-16-8	12	1/2	-8	12.7	M24x1.5	16	51	28	30
1C948-20-8	12	1/2	-8	12.7	M30x2	20	53	29	36
1C948-16-10	16	5/8	-10	15.9	M24x1.5	16	53	28	30
1C948-20-10	16	5/8	-10	15.9	M30x2	20	53	28	36
1C948-20-12	19	3/4	-12	19.1	M30x2	20	56	30	36
1C948-25-12	19	3/4	-12	19.1	M36x2	25	61	35	46
1C948-25-16	25	1	-16	25.4	M36x2	25	63	33	46
1C948-30-16	25	1	-16	25.4	M42x2	30	67	38	50
1C948-38-20°	31	1 1/4	-20	31.8	M52x2	38	80	33	60

Hose fittings are delivered with ozone resistant Nitrile (NBR) O-ring as a standard version. Working temperature from -40 °C up to +105 °C. Hose fittings with special O-rings (Viton or EPDM) available on request. For O-ring dimensions and part-numbers see Section F.

°Assembly only with Parkrimp 2 machine

Approved **fitting series** for hose types:

Also available in stainless steel. Details can be found in CAT 4400.1/UK

48 301TC 462TC 436 881

OC

**Female Metric 24° – Swivel
Heavy Series with O-Ring
45° Elbow**

ISO 12151-2 – SWE 45°-S – DKOS 45°

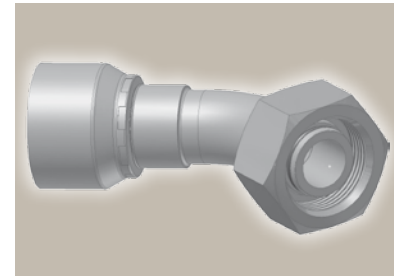
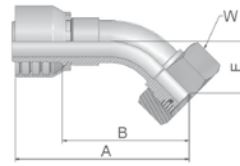

Part Number	Hose I.D.				Thread metric	Tube O.D. mm	A mm	B mm	E mm	W mm
	DN	Inch	Size	mm						
10C48-6-4	6	1/4	-4	6.4	M14x1.5	6	61	37	17	17
10C48-8-4	6	1/4	-4	6.4	M16x1.5	8	59	35	16	19
10C48-10-4	6	1/4	-4	6.4	M18x1.5	10	59	36	16	22
10C48-12-4	6	1/4	-4	6.4	M20x1.5	12	72	48	17	24
10C48-10-5	8	5/16	-5	7.9	M18x1.5	10	62	38	17	22
10C48-12-5	8	5/16	-5	7.9	M20x1.5	12	71	47	17	24
10C48-10-6	10	3/8	-6	9.5	M18x1.5	10	70	47	19	22
10C48-12-6	10	3/8	-6	9.5	M20x1.5	12	69	46	20	24
10C48-14-6	10	3/8	-6	9.5	M22x1.5	14	69	46	20	27
10C48-14-8	12	1/2	-8	12.7	M22x1.5	14	70	46	22	27
10C48-16-8	12	1/2	-8	12.7	M24x1.5	16	72	49	23	30
10C48-16-10	16	5/8	-10	15.9	M24x1.5	16	78	52	24	30
10C48-20-10	16	5/8	-10	15.9	M30x2	20	76	51	25	36
10C48-20-12	19	3/4	-12	19.1	M30x2	20	93	64	28	36
10C48-25-12	19	3/4	-12	19.1	M36x2	25	91	65	29	46
10C48-25-16	25	1	-16	25.4	M36x2	30	110	80	33	46
10C48-30-16	25	1	-16	25.4	M42x2	30	116	86	36	50
10C48-38-20°	31	1 1/4	-20	31.8	M52x2	38	140	93	37	60

Hose fittings are delivered with ozone resistant Nitrile (NBR) O-ring as a standard version. Working temperature from -40 °C up to +105 °C.
Hose fittings with special O-rings (Viton or EPDM) available on request. For O-ring dimensions and part-numbers see Section F.

°Assembly only with Parkrimp 2 machine

Approved **fitting series** for hose types:

Also available in stainless steel. Details can be found in CAT 4400.1/UK

48 301TC 462TC 436 881

1C Female Metric 24° – Swivel Heavy Series with O-Ring 90° Elbow

ISO 12151-2-SWE-S – DKOS 90°

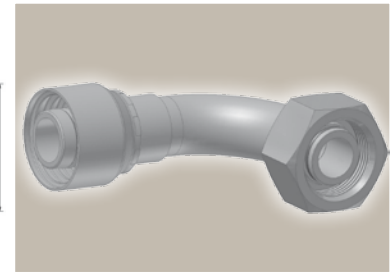
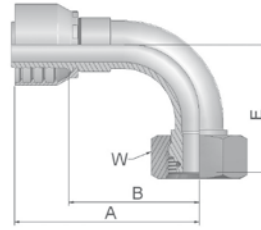

Part Number	Hose I.D.				Thread metric	Tube O.D. mm	A mm	B mm	E mm	W mm
	DN	Inch	Size	mm						
11C48-6-4	6	1/4	-4	6.4	M14x1.5	6	61	38	32	17
11C48-8-4	6	1/4	-4	6.4	M16x1.5	8	50	26	29	19
11C48-10-4	6	1/4	-4	6.4	M18x1.5	10	50	26	29	22
11C48-12-4	6	1/4	-4	6.4	M20x1.5	12	62	38	31	24
11C48-10-5	8	5/16	-5	7.9	M18x1.5	10	60	36	31	22
11C48-12-5	8	5/16	-5	7.9	M20x1.5	12	60	36	32	24
11C48-10-6	10	3/8	-6	9.5	M18x1.5	10	59	36	36	22
11C48-12-6	10	3/8	-6	9.5	M20x1.5	12	58	35	37	24
11C48-14-6	10	3/8	-6	9.5	M22x1.5	14	58	35	37	27
11C48-14-8	12	1/2	-8	12.7	M22x1.5	14	62	38	42	27
11C48-16-8	12	1/2	-8	12.7	M24x1.5	16	61	37	45	30
11C48-16-10	16	5/8	-10	15.9	M24x1.5	16	66	41	48	30
11C48-20-10	16	5/8	-10	15.9	M30x2	20	65	40	48	36
11C48-25-10	16	5/8	-10	15.9	M36x2	25	76	51	52	46
11C48-20-12	19	3/4	-12	19.1	M30x2	20	79	54	58	36
11C48-25-12	19	3/4	-12	19.1	M36x2	25	80	54	59	46
11C48-25-16	25	1	-16	25.4	M36x2	25	102	72	71	46
11C48-30-16	25	1	-16	25.4	M42x2	30	104	75	75	50
11C48-38-20°	31	1 1/4	-20	31.8	M52x2	38	130	83	78	60

Hose fittings are delivered with ozone resistant Nitrile (NBR) O-ring as a standard version. Working temperature from -40 °C up to +105 °C.
Hose fittings with special O-rings (Viton or EPDM) available on request. For O-ring dimensions and part-numbers see Section F.

°Assembly only with Parkrimp 2 machine

Approved **fitting series** for hose types:

Also available in stainless steel. Details can be found in CAT 4400.1/UK

48 301TC 462TC 436 881

D2 Male Metric 24° – Rigid Heavy Series – Straight

ISO 12151-2-S-S – CES

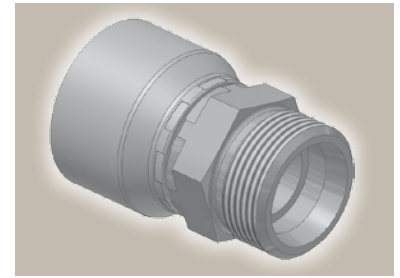
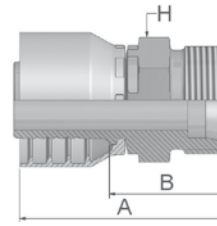

Part Number	Hose I.D.				Thread metric	Tube O.D. mm	A mm	B mm	H mm
	DN	Inch	Size	mm					
1D048-6-4	6	1/4	-4	6.4	M12x1.5	6	44	20	12
1D048-8-4	6	1/4	-4	6.4	M14x1.5	8	46	22	14
1D048-10-4	6	1/4	-4	6.4	M16x1.5	10	48	24	17
1D048-12-4	6	1/4	-4	6.4	M18x1.5	12	48	24	19
1D048-8-5	8	5/16	-5	7.9	M14x1.5	8	44	20	14
1D048-10-5	8	5/16	-5	7.9	M16x1.5	10	48	24	17
1D048-12-5	8	5/16	-5	7.9	M18x1.5	12	48	24	19
1D048-10-6	10	3/8	-6	9.5	M16x1.5	10	47	24	17
1D048-12-6	10	3/8	-6	9.5	M18x1.5	12	47	24	19
1D048-15-6	10	3/8	-6	9.5	M22x1.5	15	49	26	22
1D046-12-8	12	1/2	-8	12.7	M18x1.5	12	47	23	19
1D048-15-8	12	1/2	-8	12.7	M22x1.5	15	50	26	22
1D048-18-8	12	1/2	-8	12.7	M26x1.5	18	53	29	27
1D048-15-10	16	5/8	-10	15.9	M22x1.5	15	57	29	27
1D048-18-10	16	5/8	-10	15.9	M26x1.5	18	54	29	27
1D048-18-12	19	3/4	-12	19.1	M26x1.5	18	55	29	27
1D048-22-12	19	3/4	-12	19.1	M30x2	22	59	33	30
1D048-28-12	19	3/4	-12	19.1	M36x2	28	60	34	36
1D048-28-16	25	1	-16	25.4	M36x2	28	65	35	36
1D048-35-20	31	1 1/4	-20	31.8	M45x2	35	85	38	46
1D048-42-24	38	1 1/2	-24	38.1	M52x2	42	77	39	55

Approved fitting series for hose types:

Also available in stainless steel. Details can be found in CAT 4400.1/UK

48 301TC 462TC 436 881

92 Female BSP Parallel Pipe Swivel – Straight (60° Cone)

BS5200-A – DKR

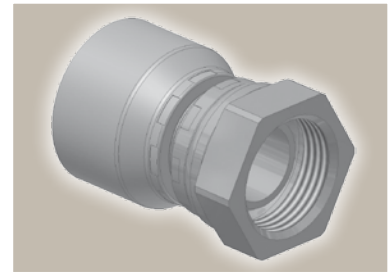
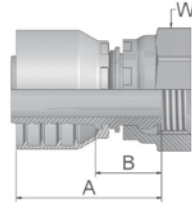

Part Number	Hose I.D.				Thread BSP	A mm	B mm	W mm
	DN	Inch	Size	mm				
19248-2-4	6	1/4	-4	6.4	1/8x28	41	17	14
19248-4-4	6	1/4	-4	6.4	1/4x19	46	19	19
19248-6-4	6	1/4	-4	6.4	3/8x19	44	20	22
19248-8-4	6	1/4	-4	6.4	1/2x14	49	25	27
19248-4-5	8	5/16	-5	7.9	1/4x19	43	19	19
19248-6-5	8	5/16	-5	7.9	3/8x19	44	20	22
19248-4-6	10	3/8	-6	9.5	1/4x19	43	20	19
19248-6-6	10	3/8	-6	9.5	3/8x19	43	20	22
19248-8-6	10	3/8	-6	9.5	1/2x14	45	22	27
19248-6-8	12	1/2	-8	12.7	3/8x19	45	21	22
19248-8-8	12	1/2	-8	12.7	1/2x14	45	22	27
19248-10-8	12	1/2	-8	12.7	5/8x14	44	21	30
19248-12-8	12	1/2	-8	12.7	3/4x14	47	23	32
19248-8-10	16	5/8	-10	15.9	1/2x14	48	22	27
19248-10-10	16	5/8	-10	15.9	5/8x14	46	20	30
19248-12-10	16	5/8	-10	15.9	3/4x14	47	22	32
19248-8-12	19	3/4	-12	19.1	1/2x14	49	23	27
19248-10-12	19	3/4	-12	19.1	5/8x14	48	22	30
19248-12-12	19	3/4	-12	19.1	3/4x14	49	23	32
19248-16-12	19	3/4	-12	19.1	1x11	51	25	41
19248-16-16	25	1	-16	25.4	1x11	55	25	41
19248-20-16	25	1	-16	25.4	1-1/4x11	63	31	50
19248-20-20	31	1 1/4	-20	31.8	1-1/4x11	79	32	50
19248-24-24	38	1 1/2	-24	38.1	1-1/2x11	71	33	60
19248-32-32	51	2	-32	50.8	2x11	84	35	70

Approved **fitting series** for hose types:

Also available in stainless steel. Details can be found in CAT 4400.1/UK

48 301TC 462TC 436 881

B1 Female BSP Parallel Pipe Swivel 45° Elbow (60° Cone)

BS 5200-D – DKR 45°

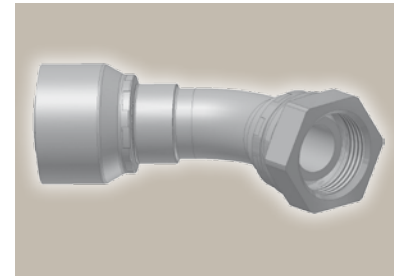
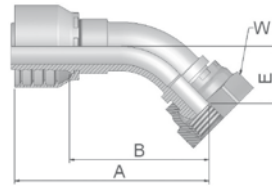

Part Number	Hose I.D.				Thread BSP	A mm	B mm	E mm	W mm
	DN	Inch	Size	mm					
1B148-4-4	6	1/4	-4	6.4	1/4x19	59	35	16	19
1B148-6-4	6	1/4	-4	6.4	3/8x19	59	35	14	22
1B148-6-5	8	5/16	-5	7.9	3/8x19	60	36	15	22
1B148-6-6	10	3/8	-6	9.5	3/8x19	69	46	17	22
1B148-8-6	10	3/8	-6	9.5	1/2x14	63	40	17	27
1B148-6-8	12	1/2	-8	12.7	3/8x19	72	49	21	22
1B148-8-8	12	1/2	-8	12.7	1/2x14	72	48	20	27
1B148-10-8	12	1/2	-8	12.7	5/8x14	69	46	19	30
1B148-10-10	16	5/8	-10	15.9	5/8x14	77	52	22	30
1B148-12-10	16	5/8	-10	15.9	3/4x14	75	49	21	32
1B148-12-12	19	3/4	-12	19.1	3/4x14	87	61	25	32
1B148-16-12	19	3/4	-12	19.1	1x11	88	62	26	41
1B148-16-16	25	1	-16	25.4	1x11	106	76	31	41
1B148-20-20	31	1 1/4	-20	31.8	1-1/4x11	139	91	35	50
1B148-24-24	38	1 1/2	-24	38.1	1-1/2x11	160	122	52	55
1B148-32-32	51	2	-32	50.8	2x11	210	161	58	70

Approved fitting series for hose types:

Also available in stainless steel. Details can be found in CAT 4400.1/UK

48 301TC 462TC 436 881

B2 Female BSP Parallel Pipe Swivel 90° Elbow (60° Cone)

BS 5200-B – DKR 90°

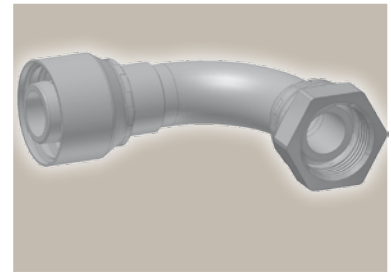
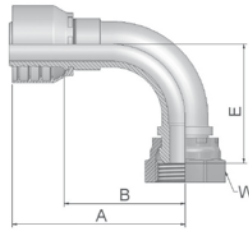

Part Number	Hose I.D.				Thread BSP	A mm	B mm	E mm	W mm
	DN	Inch	Size	mm					
1B248-2-4	6	1/4	-4	6.4	1/8x28	50	26	30	14
1B248-4-4	6	1/4	-4	6.4	1/4x19	50	26	28	19
1B248-6-4	6	1/4	-4	6.4	3/8x19	51	27	27	22
1B248-8-4	6	1/4	-4	6.4	1/2x14	51	27	29	27
1B248-6-5	8	5/16	-5	7.9	3/8x19	52	28	28	22
1B248-6-6	10	3/8	-6	9.5	3/8x19	61	38	33	22
1B248-8-6	10	3/8	-6	9.5	1/2x14	60	38	36	27
1B248-6-8	12	1/2	-8	12.7	3/8x19	63	40	41	22
1B248-8-8	12	1/2	-8	12.7	1/2x14	63	40	41	27
1B248-10-8	12	1/2	-8	12.7	5/8x14	67	43	39	30
1B248-10-10	16	5/8	-10	15.9	5/8x14	70	45	44	30
1B248-12-10	16	5/8	-10	15.9	3/4x14	70	45	42	32
1B248-12-12	19	3/4	-12	19.1	3/4x14	80	54	53	32
1B248-16-12	19	3/4	-12	19.1	1x11	80	54	54	41
1B248-16-16	25	1	-16	25.4	1x11	104	75	69	41
1B248-20-20	31	1 1/4	-20	31.8	1-1/4x11	130	82	80	50
1B248-24-24	38	1 1/2	-24	38.1	1-1/2x11	140	102	103	55
1B248-32-32	51	2	-32	50.8	2x11	185	137	134	70

Approved **fitting series** for hose types:

Also available in stainless steel. Details can be found in CAT 4400.1/UK

48 301TC 462TC 436 881

EA **BSP Swivel Female
with O-Ring (60° Cone)**
BS 5200 – ISO 12151-6 – DKOR

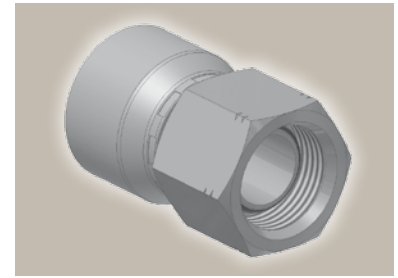
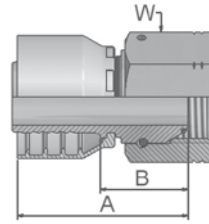

Part Number	Hose I.D.				Thread BSP	A mm	B mm	W mm
	DN	Inch	Size	mm				
1EA48-4-4	6	1/4	-4	6.4	1/4x19	45	21	19
1EA48-6-4	6	1/4	-4	6.4	3/8x19	49	26	22
1EA48-6-6	10	3/8	-6	9.5	3/8x19	48	26	22
1EA48-8-6	10	3/8	-6	9.5	1/2x14	51	28	27
1EA48-8-8	12	1/2	-8	12.7	1/2x14	52	28	27
1EA48-10-10	16	5/8	-10	15.9	5/8x14	47	21	30
1EA48-12-10	16	5/8	-10	15.9	3/4x14	54	29	32
1EA48-12-12	19	3/4	-12	19.1	3/4x14	50	24	32
1EA48-16-12	19	3/4	-12	19.1	1x11	61	35	41
1EA48-16-16	25	1	-16	25.4	1x11	62	32	41
1EA48-20-20	31	1 1/4	-20	31.8	1-1/4x11	78	31	50

Hose fittings are delivered with ozone resistant Nitrile (NBR) O-ring as a standard version. Working temperature from -40 °C up to +105 °C.
Hose fittings with special O-rings (Viton or EPDM) available on request. For O-ring dimensions and part-numbers see Section F.

EB **BSP Swivel Female
with O-Ring
45° Elbow (60° Cone)**
BS 5200 – ISO 12151-6 – DKOR 45°

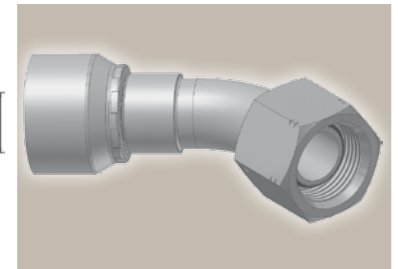
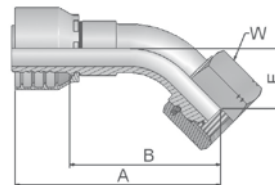

Part Number	Hose I.D.				Thread BSP	A mm	B mm	E mm	W mm
	DN	Inch	Size	mm					
1EB48-4-4	6	1/4	-4	6.4	1/4x19	59	35	16	19
1EB48-6-6	10	3/8	-6	9.5	3/8x19	69	46	17	22
1EB48-8-8	12	1/2	-8	12.7	1/2x14	72	48	20	27
1EB48-12-10	16	5/8	-10	15.9	3/4x14	78	52	21	32
1EB48-12-12	19	3/4	-12	19.1	3/4x14	89	63	27	32
1EB48-16-16	25	1	-16	25.4	1x11	113	83	33	41

Hose fittings are delivered with ozone resistant Nitrile (NBR) O-ring as a standard version. Working temperature from -40 °C up to +105 °C.
Hose fittings with special O-rings (Viton or EPDM) available on request. For O-ring dimensions and part-numbers see Section F.

Approved **fitting series** for hose types:

Also available in stainless steel. Details can be found in CAT 4400.1/UK

48 301TC 462TC 436 881

EC **BSP Swivel Female
with O-Ring
90° Elbow (60° Cone)**

BS 5200 – ISO 12151-6 – DKOR 90°

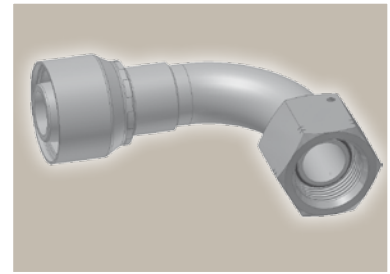
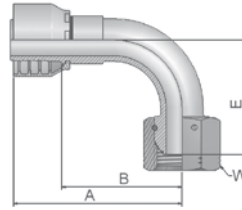

Part Number	Hose I.D.				Thread BSP	A mm	B mm	E mm	W mm
	DN	Inch	Size	mm					
1EC48-4-4	6	1/4	-4	6.4	1/4x19	50	26	28	19
1EC48-6-6	10	3/8	-6	9.5	3/8x19	61	38	33	22
1EC48-8-6	10	3/8	-6	9.5	1/2x14	60	38	36	27
1EC48-8-8	12	1/2	-8	12.7	1/2x14	63	40	40	27
1EC48-10-8	12	1/2	-8	12.7	5/8x14	63	40	39	30
1EC48-10-10	16	5/8	-10	15.9	5/8x14	70	45	44	30
1EC48-12-10	16	5/8	-10	15.9	5/8x14	70	45	42	32
1EC48-12-12	19	3/4	-12	19.1	3/4x14	80	54	55	32
1EC48-16-12	19	3/4	-12	19.1	1x11	80	54	59	41
1EC48-16-16	25	1	-16	25.4	1x11	105	75	71	41
1EC48-20-20	31	1 1/4	-20	31.8	1-1/4x11	129	82	75	50

Hose fittings are delivered with ozone resistant Nitrile (NBR) O-ring as a standard version. Working temperature from -40 °C up to +105 °C.
Hose fittings with special O-rings (Viton or EPDM) available on request. For O-ring dimensions and part-numbers see Section F.

Approved **fitting series** for hose types:

Also available in stainless steel. Details can be found in CAT 4400.1/UK

48 301TC | 462TC | 436 | 881

D9 Male BSP Parallel Pipe Rigid – Straight (60° Cone)

BS5200 – AGR

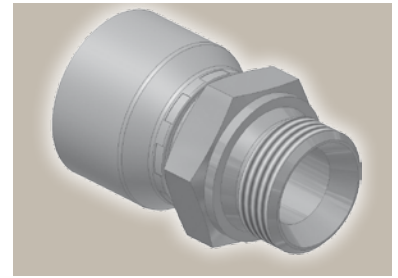
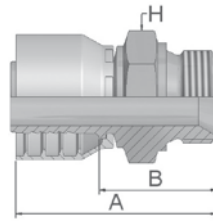

Part Number	Hose I.D.				Thread BSP	A mm	B mm	H mm
	DN	Inch	Size	mm				
1D948-2-4	6	1/4	-4	6.4	1/8x28	46	22	14
1D948-4-4	6	1/4	-4	6.4	1/4x19	51	27	19
1D948-6-4	6	1/4	-4	6.4	3/8x19	53	31	22
1D948-8-4	6	1/4	-4	6.4	1/2x14	54	52	27
1D948-4-5	8	5/16	-5	7.9	1/4x19	50	27	19
1D948-6-5	8	5/16	-5	7.9	3/8x19	55	31	22
1D948-4-6	10	3/8	-6	9.5	1/4x19	50	27	19
1D948-6-6	10	3/8	-6	9.5	3/8x19	54	31	22
1D948-8-6	10	3/8	-6	9.5	1/2x14	56	33	27
1D948-6-8	12	1/2	-8	12.7	3/8x19	54	30	22
1D948-8-8	12	1/2	-8	12.7	1/2x14	57	33	27
1D948-10-8	12	1/2	-8	12.7	5/8x14	59	35	30
1D948-12-8	12	1/2	-8	12.7	3/4x14	60	36	32
1D948-8-10	16	5/8	-10	15.9	1/2x14	59	33	27
1D948-10-10	16	5/8	-10	15.9	5/8x14	61	36	30
1D948-12-10	16	5/8	-10	15.9	3/4x14	62	37	32
1D948-12-12	19	3/4	-12	19.1	3/4x14	62	36	32
1D948-16-12	19	3/4	-12	19.1	1x11	68	42	41
1D948-16-16	25	1	-16	25.4	1x11	72	42	41
1D948-20-16	25	1	-16	25.4	1-1/4x11	75	46	50
1D948-20-20	31	1 1/4	-20	31.8	1-1/4x11	92	45	50
1D948-24-24	38	1 1/2	-24	38.1	1-1/2x11	87	49	60
1D948-32-32	51	2	-32	50.8	2	102	54	70

Approved fitting series for hose types:



Also available in stainless steel. Details can be found in CAT 4400.1/UK

48 301TC 462TC 436 881

91 Male BSP Taper Pipe – Rigid Straight

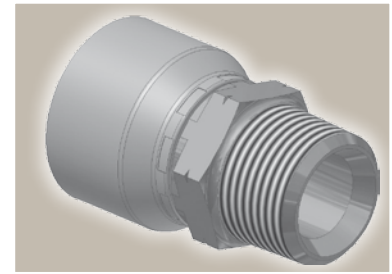
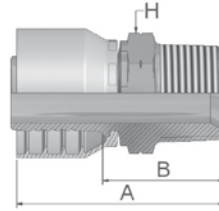
BS5200 – AGR-K



Part Number	 Hose I.D.				 Thread BSP	A mm	B mm	 H mm
	DN	Inch	Size	mm				
19148-4-4	6	1/4	-4	6.4	1/4x19	49	26	14
19148-6-4	6	1/4	-4	6.4	3/8x19	51	28	17
19148-4-5	8	5/16	-5	7.9	1/4x19	49	25	14
19148-6-5	8	5/16	-5	7.9	3/8x19	48	24	19
19148-4-6	10	3/8	-6	9.5	1/4x19	47	24	14
19148-6-6	10	3/8	-6	9.5	3/8x19	52	27	19
19148-8-6	10	3/8	-6	9.5	1/2x14	57	34	22
19148-6-8	12	1/2	-8	12.7	3/8x19	48	25	17
19148-8-8	12	1/2	-8	12.7	1/2x14	57	33	22
19148-12-10	16	5/8	-10	15.9	3/4x14	63	38	27
19148-12-12	19	3/4	-12	19.1	3/4x14	63	37	30
19148-16-16	25	1	-16	25.4	1x11	72	42	36

Approved **fitting series** for hose types:

Also available in stainless steel. Details can be found in CAT 4400.1/UK

48 301TC | 462TC | 436 | 881

01

**Male NPTF Pipe
Rigid – Straight**

SAE J476A / J516 – AGN

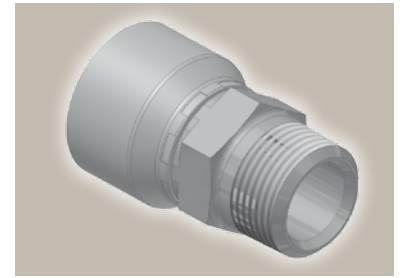
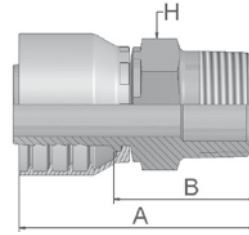

Part Number	Hose I.D.			Thread NPTF	A mm	B mm	H mm	
	DN	Inch	Size					
10148-2-4	6	1/4	-4	6.4	1/8x27	48	24	12
10148-4-4	6	1/4	-4	6.4	1/4x18	53	29	14
10148-6-4	6	1/4	-4	6.4	3/8x18	55	31	19
10148-4-5	8	5/16	-5	7.9	1/4x18	53	29	14
10148-6-5	8	5/16	-5	7.9	3/8x18	55	31	19
10148-4-6	10	3/8	-6	9.5	1/4x18	52	29	14
10148-6-6	10	3/8	-6	9.5	3/8x18	54	31	19
10148-8-6	10	3/8	-6	9.5	1/2x14	55	32	22
10148-6-8	12	1/2	-8	12.7	3/8x18	55	32	19
10148-8-8	12	1/2	-8	12.7	1/2x14	61	38	22
10148-8-10	16	5/8	-10	15.9	1/2x14	63	38	22
10148-12-10	16	5/8	-10	15.9	3/4x14	59	34	27
10148-12-12	19	3/4	-12	19.1	3/4x14	60	34	27
10148-16-16	25	1	-16	25.4	1x11-1/2	75	45	36
10148-20-20	31	1 1/4	-20	31.8	1-1/4x11-1/2	104	57	46
10148-24-24	38	1 1/2	-24	38.1	1-1/2x11-1/2	89	51	50
10148-32-32	51	2	-32	50.8	2x11-1/2	104	55	65

Approved fitting series for hose types:

Also available in stainless steel. Details can be found in CAT 4400.1/UK

48 301TC 462TC 436 881

03 Male JIC 37° – Rigid Straight

ISO12151-5-S – AGJ

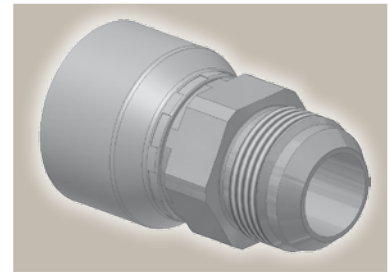
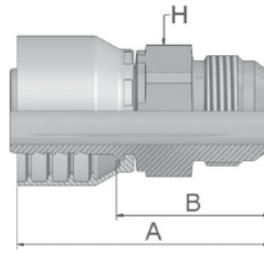

Part Number	Hose I.D.				Thread UNF	A mm	B mm	H mm
	DN	Inch	Size	mm				
10348-4-4	6	1/4	-4	6.4	7/16x20	52	29	14
10348-5-4	6	1/4	-4	6.4	1/2x20	52	29	14
10348-6-4	6	1/4	-4	6.4	9/16x18	55	31	19
10348-5-5	8	5/16	-5	7.9	1/2x20	50	26	14
10348-6-5	8	5/16	-5	7.9	9/16x18	55	31	19
10348-8-5	8	5/16	-5	7.9	3/4x16	57	33	19
10348-4-6	10	3/8	-6	9.5	7/16x20	54	31	19
10348-5-6	10	3/8	-6	9.5	1/2x20	53	30	19
10348-6-6	10	3/8	-6	9.5	9/16x18	56	31	19
10348-8-6	10	3/8	-6	9.5	3/4x16	53	30	22
10348-10-6	10	3/8	-6	9.5	7/8x14	56	33	24
10348-8-8	12	1/2	-8	12.7	3/4x16	57	34	22
10348-10-8	12	1/2	-8	12.7	7/8x14	56	32	24
10348-12-8	12	1/2	-8	12.7	1-1/16x12	62	38	27
10348-10-10	16	5/8	-10	15.9	7/8x14	63	38	24
10348-12-10	16	5/8	-10	15.9	1-1/16x12	64	39	27
10348-12-12	19	3/4	-12	19.1	1-1/16x12	68	42	27
10348-14-12	19	3/4	-12	19.1	1-3/16x12	68	42	30
10348-16-12	19	3/4	-12	19.1	1-5/16x12	64	38	36
10348-16-16	25	1	-16	25.4	1-5/16x12	76	46	36
10348-20-16	25	1	-16	25.4	1-5/8x12	73	43	46
10348-20-20	31	1 1/4	-20	31.8	1-5/8x12	101	53	46
10348-24-24	38	1 1/2	-24	38.1	1-7/8x12	85	47	50
10348-32-32	51	2	-32	50.8	2-1/2x12	109	61	65

Approved fitting series for hose types:

Also available in stainless steel. Details can be found in CAT 4400.1/UK

48 301TC 462TC 436 881

05 Male SAE Straight Thread with O-Ring – Rigid Straight

ISO 11926 – SAE J516

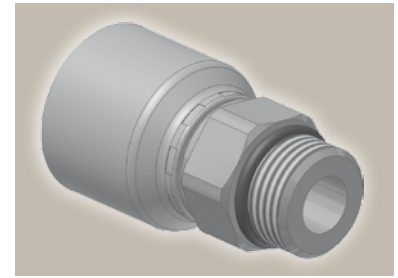
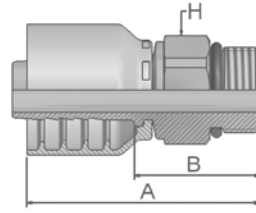

Part Number	Hose I.D.				Thread UNF	A mm	B mm	H mm
	DN	Inch	Size	mm				
10548-8-6	10	3/8	-6	9.5	3/4x16	48	25	22
10548-8-8	12	1/2	-8	12.7	3/4x16	52	28	22
10548-10-8	12	1/2	-8	12.7	7/8x14	49	26	27

To select corresponding O-ring see Section F.

Approved **fitting series** for hose types:





Also available in stainless steel. Details can be found in CAT 4400.1/UK

48 301TC 462TC 436 881

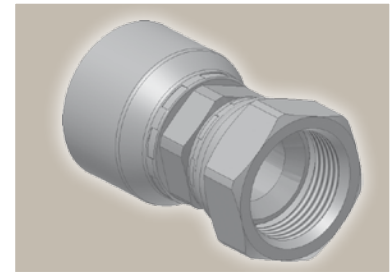
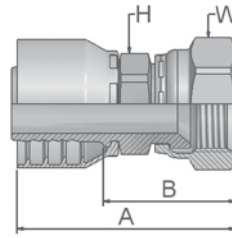
**06/68 Female – JIC 37°
SAE 45° Dual Flare
Swivel – Straight**

ISO12151-5-SWS – DKJ



Part Number	 Hose I.D.				 Thread UNF	A mm	B mm	 H mm	 W mm
	DN	Inch	Size	mm					
10648-6-4	6	1/4	-4	6.4	9/16x18	55	31	14	19
16848-4-4	6	1/4	-4	6.4	7/16x20	52	29	14	17
16848-5-4	6	1/4	-4	6.4	1/2x20	54	30	14	17
10648-6-5	8	5/16	-5	7.9	9/16x18	56	29	14	19
16848-5-5	8	5/16	-5	7.9	1/2x20	54	30	14	17
16848-8-5	8	5/16	-5	7.9	3/4x16	57	34	17	22
10648-6-6	10	3/8	-6	9.5	9/16x18	52	30	14	19
16848-4-6	10	3/8	-6	9.5	7/16x20	50	27	14	17
16848-5-6	10	3/8	-6	9.5	1/2x20	52	29	14	17
16848-8-6	10	3/8	-6	9.5	3/4x16	56	34	17	22
16848-10-6	10	3/8	-6	9.5	7/8x14	59	36	22	27
10648-6-8	12	1/2	-8	12.7	9/16x18	55	32	22	19
10648-12-8	12	1/2	-8	12.7	1-1/16x12	62	38	22	32
16848-8-8	12	1/2	-8	12.7	3/4x16	56	32	22	22
16848-10-8	12	1/2	-8	12.7	7/8x14	62	38	27	27
10648-12-10	16	5/8	-10	15.9	1-1/16x12	64	39	22	32
16848-8-10	16	5/8	-10	15.9	3/4x16	57	32	22	22
16848-10-10	16	5/8	-10	15.9	7/8x14	60	35	27	27
10648-12-12	19	3/4	-12	19.1	1-1/16x12	67	41	24	32
10648-14-12	19	3/4	-12	19.1	1-3/16x12	68	42	24	36
10648-16-12	19	3/4	-12	19.1	1-5/16x12	71	45	27	41
16848-8-12	19	3/4	-12	19.1	3/4x16	58	32	30	22
16848-10-12	19	3/4	-12	19.1	7/8x14	61	35	32	27
10648-12-16	25	1	-16	25.4	1-1/16x12	73	44	32	32
10648-16-16	25	1	-16	25.4	1-5/16x12	76	46	32	41
10648-20-16	25	1	-16	25.4	1-5/8x12	80	50	41	50
10648-16-20	31	1 1/4	-20	31.8	1-5/16x12	97	50	46	41
10648-20-20	31	1 1/4	-20	31.8	1-5/8x12	100	53	46	50
10648-24-24	38	1 1/2	-24	38.1	1-7/8x12	98	60	55	60

Approved **fitting series** for hose types:

Also available in stainless steel. Details can be found in CAT 4400.1/UK

48 301TC | 462TC | 436 | 881

37/3V Female JIC 37° SAE 45° – Dual Flare Swivel Female 45° Elbow

ISO 12151-5-SWE 45° – DKJ 45°

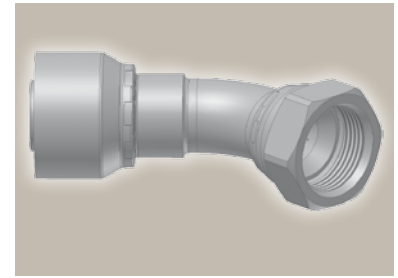
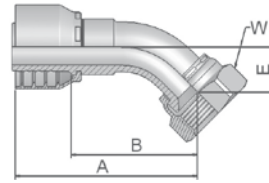

Part Number	Hose I.D.				Thread UNF	A mm	B mm	E mm	W mm
	DN	Inch	Size	mm					
13748-6-4	6	1/4	-4	6.4	9/16x18	55	31	11	19
13V48-4-4	6	1/4	-4	6.4	7/16x20	53	29	10	17
13V48-5-4	6	1/4	-4	6.4	1/2x20	57	33	9	17
13748-6-5	8	5/16	-5	7.9	9/16x18	58	35	10	19
13V48-5-5	8	5/16	-5	7.9	1/2x20	53	29	10	17
13748-6-6	10	3/8	-6	9.5	9/16x18	60	37	11	19
13V48-8-6	10	3/8	-6	9.5	3/4x16	67	44	15	22
13V48-10-6	10	3/8	-6	9.5	7/8-14	69	46	17	27
13V48-8-8	12	1/2	-8	12.7	3/4x16	61	37	15	22
13V48-10-8	12	1/2	-8	12.7	7/8x14	70	46	16	27
13748-12-10	16	5/8	-10	15.9	1-1/16x12	74	49	21	32
13V48-10-10	16	5/8	-10	15.9	7/8x14	69	44	16	27
13748-12-12	19	3/4	-12	19.1	1-1/16x12	83	58	22	32
13748-14-12	19	3/4	-12	19.1	1-3/16x12	84	58	22	36
13748-16-12	19	3/4	-12	19.1	1-5/16x12	84	58	24	41
13748-12-16	25	1	-16	25.4	1-1/16x12	91	61	21	32
13748-16-16	25	1	-16	25.4	1-5/16x12	99	70	24	41
13748-20-16	25	1	-16	25.4	1-5/8x12	101	71	26	50
13748-20-20	31	1 1/4	-20	31.8	1-5/8x12	134	87	30	50
13748-24-24	38	1 1/2	-24	38.1	1-7/8x12	165	127	58	60

Approved fitting series for hose types:

Also available in stainless steel. Details can be found in CAT 4400.1/UK

48 301TC 462TC 436 881

39/3W Female JIC 37° SAE 45° – Dual Flare Swivel Female 90° Elbow

ISO 12151-5-SWES – DKJ 90°

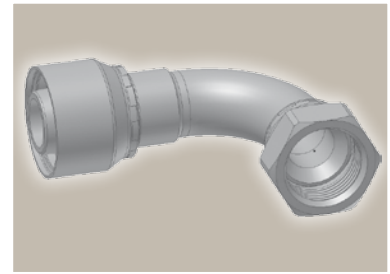
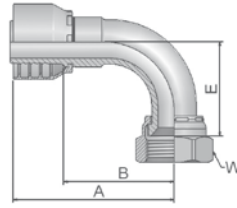

Part Number	Hose I.D.				Thread UNF	A mm	B mm	E mm	W mm
	DN	Inch	Size	mm					
13948-6-4	6	1/4	-4	6.4	9/16x18	49	25	23	19
13W48-4-4	6	1/4	-4	6.4	7/16x20	48	24	21	17
13W48-5-4	6	1/4	-4	6.4	1/2x20	58	34	21	17
13948-6-5	8	5/16	-5	7.9	9/16x18	51	28	23	19
13W48-5-5	8	5/16	-5	7.9	1/2x20	49	25	21	17
13948-6-6	10	3/8	-6	9.5	9/16x18	51	28	23	19
13W48-4-6	10	3/8	-6	9.5	7/16x20	46	23	21	17
13W48-8-6	10	3/8	-6	9.5	3/4x16	59	36	29	22
13W48-10-6	10	3/8	-6	9.5	7/8x14	61	38	32	27
13948-6-8	12	1/2	-8	12.7	9/16x18	54	30	23	19
13W48-8-8	12	1/2	-8	12.7	3/4x16	55	31	29	22
13W48-10-8	12	1/2	-8	12.7	7/8x14	63	39	32	27
13948-12-10	16	5/8	-10	15.9	1-1/16x12	75	49	48	32
13W48-10-10	16	5/8	-10	15.9	7/8x14	64	39	33	27
13948-12-12	19	3/4	-12	19.1	1-1/16x12	80	54	48	32
13948-14-12	19	3/4	-12	19.1	1-3/16x12	80	54	51	36
13948-16-12	19	3/4	-12	19.1	1-5/16x12	80	54	56	41
13948-12-16	25	1	-16	25.4	1-1/16x12	88	58	48	32
13948-16-16	25	1	-16	25.4	1-5/16x12	98	68	56	41
13948-20-16	25	1	-16	25.4	1-5/8x12	98	68	62	50
13948-20-20	31	1 1/4	-20	31.8	1-5/8x12	129	82	70	50
13948-24-20°	31	1 1/4	-20	31.8	1-7/8x12	130	82	80	60
13948-24-24	38	1 1/2	-24	38.1	1-7/8x12	140	102	84	60
13948-32-32	51	2	-32	50.8	2-1/2x12	185	137	145	75

°Assembly only with Parkrimp 2 machine

Approved **fitting series** for hose types:

Also available in stainless steel. Details can be found in CAT 4400.1/UK

48 301TC 462TC 436 881

15

ISO 6162-1 Flange Straight

ISO 12151-3-S-L – SFL

(21.0 MPa/ 3000 psi)

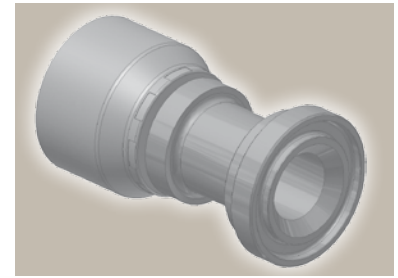
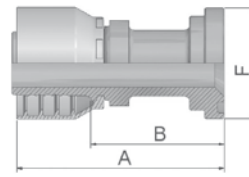

Part Number	Hose I.D.				Flange Inch	A mm	B mm	F mm
	DN	Inch	Size	mm				
11548-8-8	12	1/2	-8	12.7	1/2	74	51	30
11548-12-8	12	1/2	-8	12.7	3/4	51	27	38
11548-12-10	16	5/8	-10	15.9	3/4	56	31	38
11548-12-12	19	3/4	-12	19.1	3/4	82	56	38
11548-16-12	19	3/4	-12	19.1	1	56	30	45
11548-20-12	19	3/4	-12	19.1	1-1/4	77	51	51
11548-16-16	25	1	-16	25.4	1	84	54	45
11548-20-16	25	1	-16	25.4	1-1/4	65	35	51
11548-24-16	25	1	-16	25.4	1-1/2	97	67	60
11548-16-20	31	1 1/4	-20	31.8	1	111	64	45
11548-20-20	31	1 1/4	-20	31.8	1-1/4	120	72	51
11548-24-24	38	1 1/2	-24	38.1	1-1/2	117	79	60
11548-32-24	38	1 1/2	-24	38.1	2	80	42	71
11548-24-32	51	2	-32	50.8	1-1/2	129	81	60
11548-32-32	51	2	-32	50.8	2	127	79	71
K1547-40-40*	63	2 1/2	-40	63.5	2 1/2	126	65	84
K1547-48-48*	76	3	-48	76.2	3	115	85	101

* 2piece 48 Series

To select corresponding O-ring see Section F.

Approved **fitting series** for hose types:

Also available in stainless steel. Details can be found in CAT 4400.1/UK

48 301TC 462TC 436 881

17 ISO 6162-1 Flange 45° Elbow

ISO 12151-3 – E45 – L – SFL 45°
(21.0 MPa/ 3000 psi)

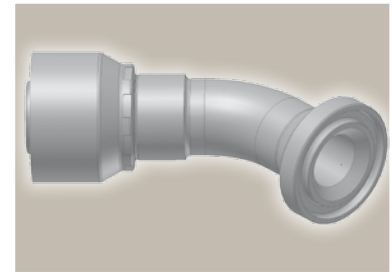
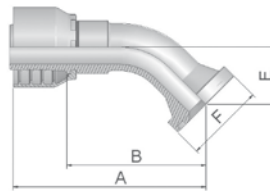

Part Number	Hose I.D.				Flange Inch	A mm	B mm	E mm	F mm
	DN	Inch	Size	mm					
11748-8-8	12	1/2	-8	12.7	1/2	72	48	20	30
11748-12-8	12	1/2	-8	12.7	3/4	71	47	21	38
11748-12-10	16	5/8	-10	15.9	3/4	75	50	24	38
11748-12-12	19	3/4	-12	19.1	3/4	88	62	26	38
11748-16-12	19	3/4	-12	19.1	1	88	62	26	45
11748-20-12	19	3/4	-12	19.1	1-1/4	87	61	25	51
11748-16-16	25	1	-16	25.4	1	109	78	32	45
11748-20-16	25	1	-16	25.4	1-1/4	109	79	32	51
11748-16-20	31	1 1/4	-20	31.8	1	141	94	38	45
11748-20-20	31	1 1/4	-20	31.8	1-1/4	141	94	38	51
11748-24-24	38	1 1/2	-24	38.1	1-1/2	151	113	44	60
11748-32-24	38	1 1/2	-24	38.1	2	150	112	44	71
11748-24-32	51	2	-32	50.8	1-1/2	153	105	36	60
11748-32-32	51	2	-32	50.8	2	202	153	56	71

To select corresponding O-ring see Section F.

Approved **fitting series** for hose types:

Also available in stainless steel. Details can be found in CAT 4400.1/UK

48 301TC 462TC 436 881

19

ISO 6162-1 Flange 90° Elbow

ISO 12151-3 – E- L – SFL 90°

(21.0 MPa/ 3000 psi)

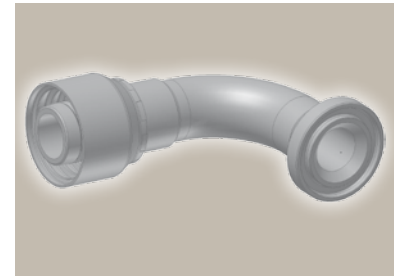
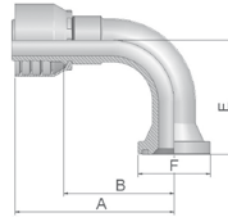

Part Number	Hose I.D.			Flange Inch	A mm	B mm	E mm	F mm	
	DN	Inch	Size						mm
11948-8-8	12	1/2	-8	12.7	1/2	64	40	41	30
11948-12-8	12	1/2	-8	12.7	3/4	71	47	43	38
11948-12-10	16	5/8	-10	15.9	3/4	78	53	52	38
11948-16-10	16	5/8	-10	15.9	1	78	53	52	45
11948-12-12	19	3/4	-12	19.1	3/4	80	54	58	38
11948-16-12	19	3/4	-12	19.1	1	80	54	58	45
11948-20-12	19	3/4	-12	19.1	1-1/4	81	55	54	51
11948-12-16	25	1	-16	25.4	3/4	98	68	70	38
11948-16-16	25	1	-16	25.4	1	98	68	70	45
11948-20-16	25	1	-16	25.4	1-1/4	102	72	70	51
11948-24-16	25	1	-16	25.4	1-1/2	100	70	62	60
11948-20-20	31	1 1/4	-20	31.8	1-1/4	130	82	90	51
11948-24-20	31	1 1/4	-20	31.8	1-1/2	129	82	90	60
11948-24-24	38	1 1/2	-24	38.1	1-1/2	140	102	79	60
11948-32-24	38	1 1/2	-24	38.1	2	139	101	104	71
11948-24-32	51	2	-32	50.8	1-1/2	154	106	104	60
11948-32-32	51	2	-32	50.8	2	186	138	114	71

°Assembly only with Parkrimp 2 machine
To select corresponding O-ring see Section F.

Approved **fitting series** for hose types:

Also available in stainless steel. Details can be found in CAT 4400.1/UK

48 301TC 462TC 436 881

6A ISO 6162-2 Flange Straight

ISO 12151-3-S-S – SFS

(42.0 MPa/ 6000 psi)

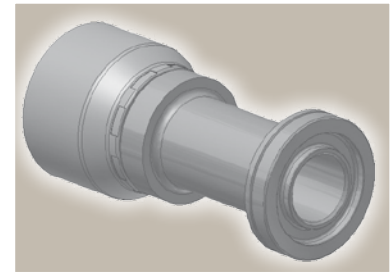
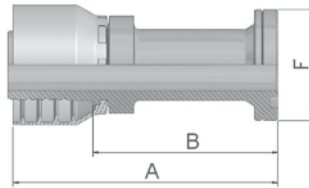

Part Number	Hose I.D.				Flange Inch	A mm	B mm	F mm
	DN	Inch	Size	mm				
16A48-8-8	12	1/2	-8	12.7	1/2	75	51	32
16A48-12-10	16	5/8	-10	15.9	3/4	60	35	41
16A48-12-12	19	3/4	-12	19.1	3/4	96	70	41
16A48-12-16	25	1	-16	25.4	3/4	99	69	41
16A48-16-16	25	1	-16	25.4	1	111	81	48
16A48-20-20	31	1 1/4	-20	31.8	1-1/4	130	83	54
16A48-24-24	38	1 1/2	-24	38.1	1-1/2	139	101	64
16A48-32-32	51	2	-32	50.8	2	172	124	79

To select corresponding O-ring see Section F.

6F ISO 6162-2 Flange 45° Elbow – Heavy Series

ISO 12151-3 – E45-S – SFS 45°

(42.0 MPa/ 6000 psi)

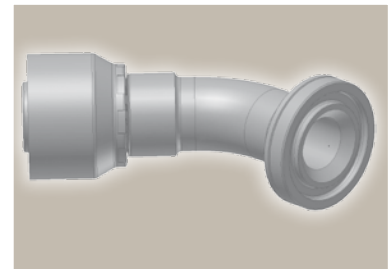
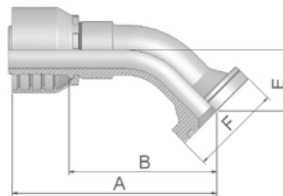

Part Number	Hose I.D.				Flange Inch	A mm	B mm	E mm	F mm
	DN	Inch	Size	mm					
16F48-12-12	19	3/4	-12	19.1	3/4	88	62	26	41
16F48-16-16	25	1	-16	25.4	1	107	78	32	48
16F48-20-20	31	1 1/4	-20	31.8	1-1/4	141	94	38	54
16F48-24-24	38	1 1/2	-24	38.1	1-1/2	150	112	44	64
16F48-32-32	51	2	-32	50.8	2	183	135	52	79

To select corresponding O-ring see Section F.

Approved **fitting series** for hose types:

Also available in stainless steel. Details can be found in CAT 4400.1/UK

48 301TC 462TC 436 881



6N

**ISO 6162-2 Flange
90° Elbow**

ISO 12151-3 – E-S – SFS 90°

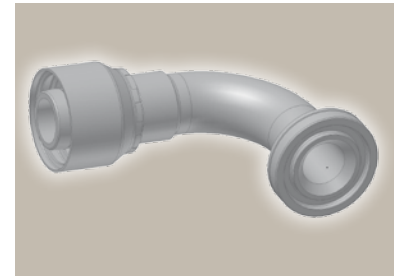
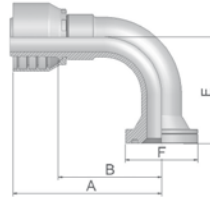
(42.0 MPa/ 6000 psi)



Part Number	 Hose I.D.				 Flange	A mm	B mm	E mm	F mm
	DN	Inch	Size	mm					
16N48-8-12	19	3/4	-12	19.1	1/2	70	44	40	32
16N48-12-12	19	3/4	-12	19.1	3/4	80	54	54	41
16N48-16-12	19	3/4	-12	19.1	1	80	54	53	48
16N48-12-16	25	1	-16	25.4	3/4	88	58	58	41
16N48-16-16	25	1	-16	25.4	1	98	68	70	48
16N48-20-20	31	1 1/4	-20	31.8	1-1/4	130	82	70	54
16N48-24-24	38	1 1/2	-24	38.1	1-1/2	139	101	104	64
16N48-32-32	51	2	-32	50.8	2	172	124	115	79
16N48-32-32	51	2	-32	50.8	2	172	124	115	79

To select corresponding O-ring see Section F.

Approved **fitting series** for hose types:

Also available in stainless steel. Details can be found in CAT 4400.1/UK

48 301TC 462TC 436 881

EN UPTC – Male
Straight

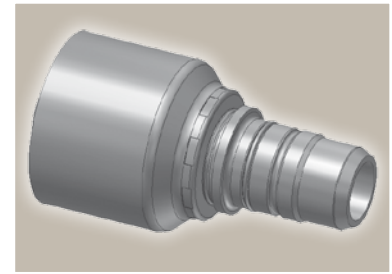
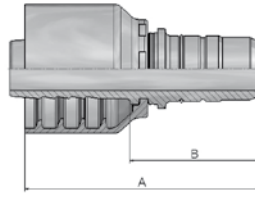

Part Number	 Hose I.D.				Tube O.D. mm	A mm	B mm
	DN	Inch	Size	mm			
1EN48-8-4	6	1/4	-4	6.4	8	49	26
1EN48-10-5	8	5/16	-5	7.9	10	50	26
1EN48-12-6	10	3/8	-6	9.5	12	50	27
1EN48-15-8	12	1/2	-8	12.7	15	53	29
1EN48-18-10	16	5/8	-10	15.9	18	56	31
1EN48-22-12	19	3/4	-12	19.1	22	58	33

EU UPTC – Male
45° Elbow

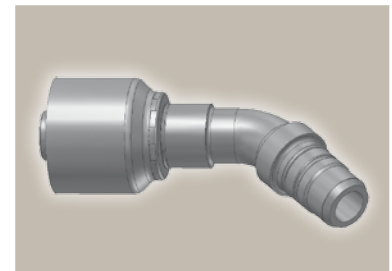
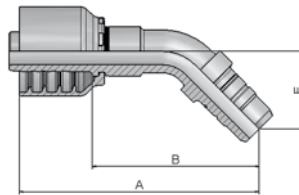

Part Number	 Hose I.D.				Tube O.D. mm	A mm	B mm	E mm
	DN	Inch	Size	mm				
1EU48-8-4	6	1/4	-4	6.4	8	66	43	23
1EU48-10-5	8	5/16	-5	7.9	10	68	45	23
1EU48-12-6	10	3/8	-6	9.5	12	71	48	23
1EU48-15-8	12	1/2	-8	12.7	15	78	54	25
1EU48-18-10	16	5/8	-10	15.9	18	84	59	32
1EU48-22-12	19	3/4	-12	19.1	22	95	69	33

Approved **fitting series** for hose types:

Also available in stainless steel. Details can be found in CAT 4400.1/UK

48 301TC | 462TC | 436 | 881

ET **UPTC – Male**
90° Elbow

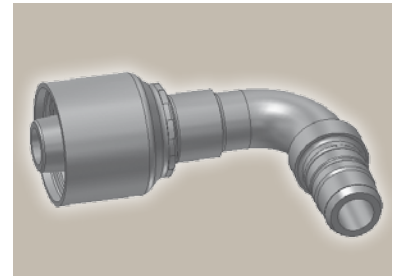
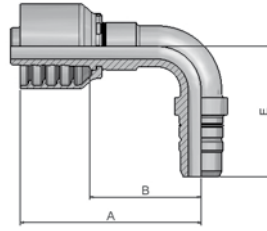

Part Number	 Hose I.D.				Tube	A mm	B mm	E mm
	DN	Inch	Size	mm	O.D. mm			
1ET48-8-4	6	1/4	-4	6.4	8	59	36	39
1ET48-10-5	8	5/16	-5	7.9	10	58	35	39
1ET48-12-6	10	3/8	-6	9.5	12	57	34	40
1ET48-15-8	12	1/2	-8	12.7	15	61	38	45
1ET48-18-10	16	5/8	-10	15.9	18	65	39	57
1ET48-22-12	19	3/4	-12	19.1	22	80	54	64

Approved **fitting series** for hose types:

Also available in stainless steel. Details can be found in CAT 4400.1/UK

48 301TC 462TC 436 881

SteckO®

Page Cc-1

S0

Cc-1

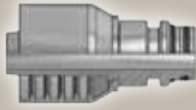

SteckO® fitting
Straight

DIN – Metric

Page Cc-2 – Cc-5

CA

Cc-2

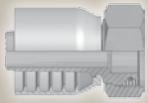

Female Metric 24°
Light Series with O-Ring
Swivel – Straight
ISO 12151-2-SWS-L – DKOL

CE

Cc-2

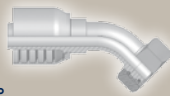

Female Metric 24°
Light Series with O-Ring
Swivel – 45° Elbow
ISO 12151-2-SWE 45°-L – DKOL 45°

CF

Cc-3

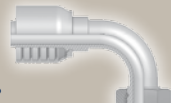

Female Metric 24°
Light Series with O-Ring
Swivel – 90° Elbow
ISO 12151-2-SWE-L – DKOL 90°

D0

Cc-3

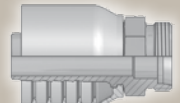

Male Metric 24°
Light Series – Rigid
Straight
ISO 12151-2-S-L – CEL

C9

Cc-4

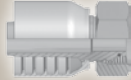

Female Metric 24° – Swivel
Heavy Series with O-Ring
Straight
ISO 12151-2-SWS-S – DKOS

OC

Cc-4



Female Metric 24° – Swivel
Heavy Series with O-Ring
45° Elbow
ISO 12151-2 – SWE 45°-S – DKOS 45°

1C

Cc-5



Female Metric 24° – Swivel
Heavy Series with O-Ring
90° Elbow
ISO 12151-2-SWE-S – DKOS 90°

D2

Cc-5

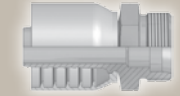

Male Metric 24° – Rigid
Heavy Series – Straight
ISO 12151-2-S-S – CES

BSP

Page Cc-6 – Cc-8

92

Cc-6

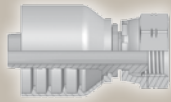

Female BSP Parallel Pipe
Swivel – Straight (60° Cone)
BS5200-A – DKR

B1

Cc-6



Female BSP Parallel Pipe
Swivel
45° Elbow (60° Cone)
BS 5200-D – DKR 45°

B2

Cc-7



Female BSP Parallel Pipe
Swivel
90° Elbow (60° Cone)
BS 5200-B – DKR 90°

EA

Cc-7

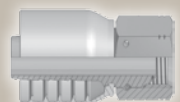

BSP Swivel Female
with O-Ring (60° Cone)
BS 5200 – ISO 12151-6 – DKOR

EC

Cc-8

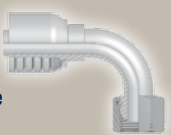

BSP Swivel Female
with O-Ring
90° Elbow (60° Cone)
BS 5200 – ISO 12151-6 – DKOR 90°

D9

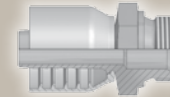

Cc-8



Male BSP Parallel Pipe
Rigid – Straight (60° Cone)
BS5200 – AGR

SAE

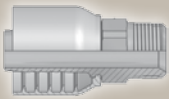
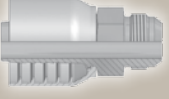
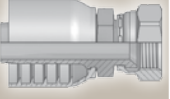
Page Cc-9 – Cc-11

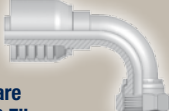
<p>01 Cc-9</p>  <p>Male NPTF Pipe Rigid – Straight SAE J476A / J516 – AGN</p>	<p>03 Cc-9</p>  <p>Male JIC 37° – Rigid Straight ISO12151-5-S – AGJ</p>	<p>06 Cc-10</p>  <p>Female JIC 37° – Swivel Straight ISO12151-5-SWS – DKJ</p>	<p>37 Cc-10</p>  <p>Female JIC 37° – Swivel 45° Elbow ISO 12151-5-SWE 45° – DKJ 45°</p>
<p>39/3W Cc-11</p>  <p>Female JIC 37° SAE 45° – Dual Flare Swivel Female 90° Elbow ISO 12151-5-SWES – DKJ 90°</p>			

Flange

Page Cc-11 – Cc-13

<p>15 Cc-11</p>  <p>ISO 6162-1 Flange Straight ISO 12151-3-S-L – SFL (21.0 MPa/ 3000 psi)</p>	<p>17 Cd-11</p>  <p>ISO 6162-1 Flange 45° Elbow ISO 12151-3 – E45 – L – SFL 45° (21.0 MPa/ 3000 psi)</p>	<p>19 Cd-12</p>  <p>ISO 6162-1 Flange 90° Elbow ISO 12151-3 – E – L – SFL 90° (21.0 MPa/ 3000 psi)</p>
<p>6A Cd-12</p>  <p>ISO 6162-2 Flange Straight ISO 12151-3-S-S – SFS (42.0 MPa/ 6000 psi)</p>	<p>6F Cd-13</p>  <p>ISO 6162-2 Flange 45° Elbow – Heavy Series ISO 12151-3 – E45-S – SFS 45° (42.0 MPa/ 6000 psi)</p>	<p>6N Cc-13</p>  <p>ISO 6162-2 Flange 90° Elbow ISO 12151-3 – E – S – SFS 90° (42.0 MPa/ 6000 psi)</p>

S0 **SteckO® fitting**
Straight

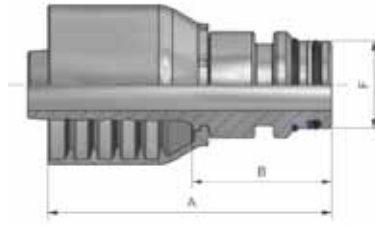

Part Number	 Hose I.D.				A	B	F
	DN	Inch	Size	mm	mm	mm	mm
1S070-6-6	10	3/8	-6	9.5	65	36	14
1S070-8-8	12	1/2	-8	12.7	72	37	18
1S070-12-12	16	5/8	-10	15.9	78	38	24

Approved **fitting series** for hose types:

Also available in stainless steel. Details can be found in CAT 4400.1/UK



CA Female Metric 24° Light Series with O-Ring Swivel – Straight

ISO 12151-2-SWS-L – DKOL

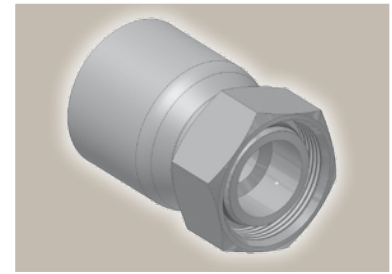
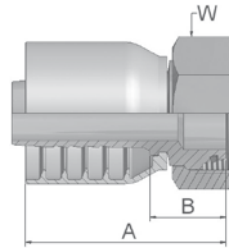

Part Number	Hose I.D.				Thread metric	Tube O.D. mm	A mm	B mm	W mm
	DN	Inch	Size	mm					
1CA70-10-6	10	3/8	-6	9.5	M16x1.5	10	53	24	19
1CA70-12-6	10	3/8	-6	9.5	M18x1.5	12	53	24	22
1CA70-15-8	12	1/2	-8	12.7	M22x1.5	15	62	27	27
1CA70-18-8	12	1/2	-8	12.7	M26x1.5	18	57	22	32
1CA70-15-10	16	5/8	-10	15.9	M22x1.5	15	64	27	27
1CA70-18-10	16	5/8	-10	15.9	M26x1.5	18	62	26	32
1CA70-22-10	16	5/8	-10	15.9	M30x2	22	64	24	36
1CA70-18-12	19	3/4	-12	19.1	M26x1.5	18	65	26	32
1CA70-22-12	19	3/4	-12	19.1	M30x2	22	63	24	36
1CA70-28-12	19	3/4	-12	19.1	M36x2	28	66	26	41
1CA70-28-16	25	1	-16	25.4	M36x2	28	78	33	41
1CA70-35-16	25	1	-16	25.4	M45x2	35	76	31	50

Fittings with standard O-ring seals can be used for temperatures from -40 °C up to +105 °C.
Find O-rings in section F. Special O-rings are available on request.
Attention: Hose assembly pressure is reduced; see CAT/4400 page Ab-8

CE Female Metric 24° Light Series with O-Ring Swivel – 45° Elbow

ISO 12151-2-SWE 45°-L – DKOL 45°

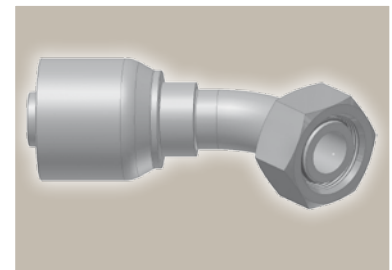
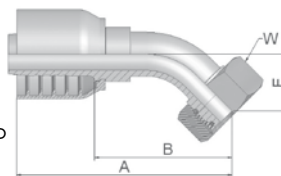

Part Number	Hose I.D.				Thread metric	Tube O.D. mm	A mm	B mm	E mm	W mm
	DN	Inch	Size	mm						
1CE70-12-6	10	3/8	-6	9.5	M18x1.5	12	69	40	20	22
1CE70-15-8	12	1/2	-8	12.7	M22x1.5	15	85	50	24	27
1CE70-18-10	16	5/8	-10	15.9	M26x1.5	18	89	49	23	32
1CE70-22-12	19	3/4	-12	19.1	M30x2	22	98	58	26	36
1CE70-28-16	25	1	-16	25.4	M36x2	28	125	80	34	41

Fittings with standard O-ring seals can be used for temperatures from -40 °C up to +105 °C.
Find O-rings in section F. Special O-rings are available on request.
Attention: Hose assembly pressure is reduced; see CAT/4400 page Ab-8

Approved **fitting series** for hose types:

Also available in stainless steel. Details can be found in CAT 4400.1/UK

70 CM4SPP

CF

Female Metric 24° Light Series with O-Ring Swivel – 90° Elbow

ISO 12151-2-SWE-L – DKOL 90°

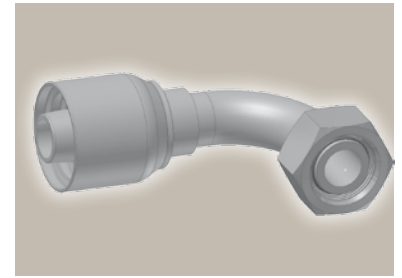
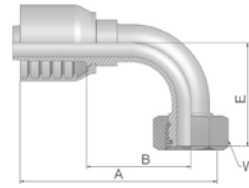

Part Number	Hose I.D.				Thread metric	Tube O.D. mm	A mm	B mm	E mm	W mm
	DN	Inch	Size	mm						
1CF70-10-6	10	3/8	-6	9.5	M16x1.5	10	67	38	38	19
1CF70-12-6	10	3/8	-6	9.5	M18x1.5	12	67	38	37	22
1CF70-15-8	12	1/2	-8	12.7	M22x1.5	15	74	39	45	27
1CF70-18-8	12	1/2	-8	12.7	M26x1.5	18	71	36	40	32
1CF70-15-10	16	5/8	-10	15.9	M22x1.5	15	79	42	50	27
1CF70-18-10	16	5/8	-10	15.9	M26x1.5	18	79	42	49	32
1CF70-18-12	19	3/4	-12	19.1	M26x1.5	18	89	50	56	32
1CF70-22-12	19	3/4	-12	19.1	M30x2	22	89	49	55	36
1CF70-28-16	25	1	-16	25.4	M36x2	28	113	68	73	41
1CF70-35-16	25	1	-16	25.4	M45x2	35	115	68	69	50

Fittings with standard O-ring seals can be used for temperatures from -40 °C up to +105 °C.
Find O-rings in section F. Special O-rings are available on request.
Attention: Hose assembly pressure is reduced; see CAT/4400 page Ab-8

DO

Male Metric 24° Light Series – Rigid Straight

ISO 12151-2-S-L – CEL

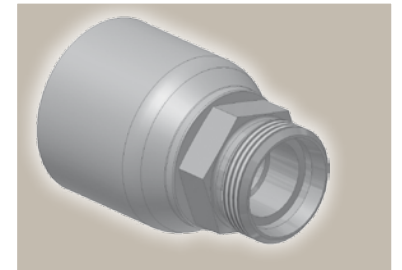
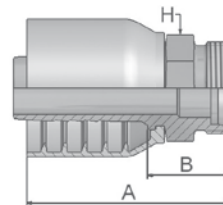

Part Number	Hose I.D.				Thread metric	Tube O.D. mm	A mm	B mm	H mm
	DN	Inch	Size	mm					
1D070-15-8	12	1/2	-8	12.7	M22x1.5	15	60	26	22
1D070-18-10	16	5/8	-10	15.9	M26x1.5	18	65	28	27
1D070-22-12	19	3/4	-12	19.1	M30x2	22	69	30	30
1D070-28-16	25	1	-16	25.4	M36x2	28	79	32	36

Attention: Hose assembly pressure is reduced; see CAT/4400 page Ab-8

Approved **fitting series** for hose types:

Also available in stainless steel. Details can be found in CAT 4400.1/UK

70 CM4SPP

C9 Female Metric 24° – Swivel Heavy Series with O-Ring Straight

ISO 12151-2-SWS-S – DKOS

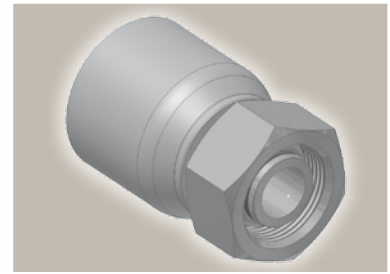
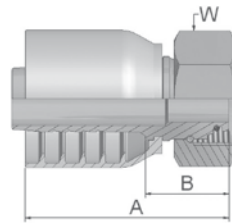

Part Number	Hose I.D.				Thread metric	Tube O.D. mm	A mm	B mm	W mm
	DN	Inch	Size	mm					
1C970-8-6	10	3/8	-6	9.5	M16x1.5	8	53	24	19
1C970-12-6	10	3/8	-6	9.5	M20x1.5	12	52	22	24
1C970-14-6	10	3/8	-6	9.5	M22x1.5	14	53	24	27
1C970-12-8	12	1/2	-8	12.7	M20x1.5	12	60	25	24
1C970-16-8	12	1/2	-8	12.7	M24x1.5	16	59	24	30
1C970-20-8	12	1/2	-8	12.7	M30x2	20	59	25	36
1C970-16-10	16	5/8	-10	15.9	M24x1.5	16	67	27	30
1C970-20-10	16	5/8	-10	15.9	M30x2	20	64	27	36
1C970-25-10	16	5/8	-10	15.9	M36x2	25	65	29	46
1C970-20-12	19	3/4	-12	19.1	M30x2	20	67	27	36
1C970-25-12	19	3/4	-12	19.1	M36x2	25	68	28	46
1C970-25-16	25	1	-16	25.4	M36x2	25	78	33	46
1C970-30-16	25	1	-16	25.4	M42x2	30	80	33	50

Fittings with standard O-ring seals can be used for temperatures from -40 °C up to +105 °C. Find O-rings in section F. Special O-rings are available on request.

0C Female Metric 24° – Swivel Heavy Series with O-Ring 45° Elbow

ISO 12151-2 – SWE 45°-S – DKOS 45°

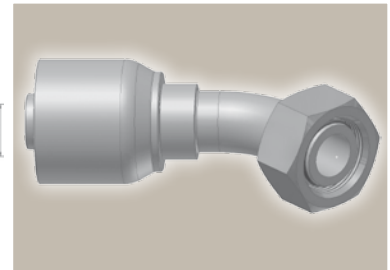
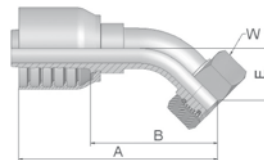

Part Number	Hose I.D.				Thread metric	Tube O.D. mm	A mm	B mm	E mm	W mm
	DN	Inch	Size	mm						
10C70-12-6	10	3/8	-6	9.5	M20x1.5	12	69	40	20	24
10C70-14-6	10	3/8	-6	9.5	M22x1.5	14	76	46	20	27
10C70-16-8	12	1/2	-8	12.7	M24x1.5	16	83	48	24	30
10C70-16-10	16	5/8	-10	15.9	M24x1.5	16	89	49	23	30
10C70-20-10	16	5/8	-10	15.9	M30x2	20	91	52	25	36
10C70-25-10	16	5/8	-10	15.9	M36x2	25	92	56	27	46
10C70-20-12	19	3/4	-12	19.1	M30x2	20	100	60	29	36
10C70-25-12	19	3/4	-12	19.1	M36x2	25	101	61	30	46
10C70-25-16	25	1	-16	25.4	M36x2	25	127	75	32	46
10C70-30-16	25	1	-16	25.4	M42x2	30	126	79	36	50

Fittings with standard O-ring seals can be used for temperatures from -40 °C up to +105 °C. Find O-rings in section F. Special O-rings are available on request.

Approved **fitting series** for hose types:

Also available in stainless steel. Details can be found in CAT 4400.1/UK

70 CM4SPP

1C Female Metric 24° – Swivel Heavy Series with O-Ring 90° Elbow

ISO 12151-2-SWE-S – DKOS 90°

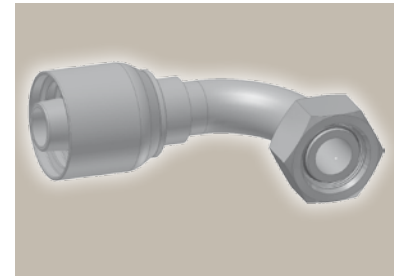
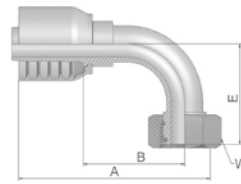

Part Number	Hose I.D.				Thread metric	Tube O.D. mm	A mm	B mm	E mm	W mm
	DN	Inch	Size	mm						
11C70-8-6	10	3/8	-6	9.5	M16x1.5	8	67	38	37	19
11C70-12-6	10	3/8	-6	9.5	M20x1.5	12	67	38	37	24
11C70-14-6	10	3/8	-6	9.5	M22x1.5	14	65	35	37	27
11C70-16-8	12	1/2	-8	12.7	M24x1.5	16	72	37	45	30
11C70-20-8	12	1/2	-8	12.7	M30x2	20	75	40	46	36
11C70-16-10	16	5/8	-10	15.9	M24x1.5	16	79	40	45	30
11C70-20-10	16	5/8	-10	15.9	M30x2	20	79	40	48	36
11C70-25-10	16	5/8	-10	15.9	M36x2	25	85	46	52	46
11C70-25-12	19	3/4	-12	19.1	M36x2	25	89	49	59	46
11C70-30-12	19	3/4	-12	19.1	M42x2	30	89	50	60	50
11C70-25-16	25	1	-16	25.4	M36x2	25	115	68	70	46
11C70-30-16	25	1	-16	25.4	M42x2	30	115	68	76	50

Fittings with standard O-ring seals can be used for temperatures from -40 °C up to +105 °C.
Find O-rings in section F. Special O-rings are available on request.

D2 Male Metric 24° – Rigid Heavy Series – Straight

ISO 12151-2-S-S – CES

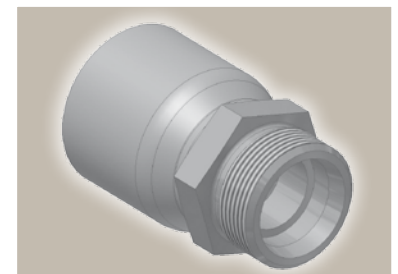
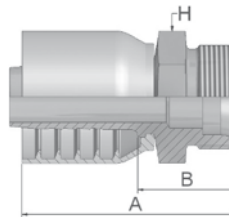

Part Number	Hose I.D.				Thread metric	Tube O.D. mm	A mm	B mm	H mm
	DN	Inch	Size	mm					
1D270-12-6	10	3/8	-6	9.5	M20x1.5	12	53	24	22
1D270-14-6	10	3/8	-6	9.5	M22x1.5	14	55	25	22
1D270-16-8	12	1/2	-8	12.7	M24x1.5	16	62	28	24
1D270-20-8	12	1/2	-8	12.7	M30x2	20	67	32	30
1D270-20-10	16	5/8	-10	15.9	M30x2	20	75	32	30
1D270-20-12	19	3/4	-12	19.1	M30x2	20	72	33	30
1D270-25-12	19	3/4	-12	19.1	M36x2	25	74	35	36
1D270-25-16	25	1	-16	25.4	M36x2	25	84	37	36
1D270-30-16	25	1	-16	25.4	M42x2	30	85	40	46

Approved **fitting series** for hose types:

Also available in stainless steel. Details can be found in CAT 4400.1/UK



92 Female BSP Parallel Pipe Swivel – Straight (60° Cone)

BS5200-A – DKR

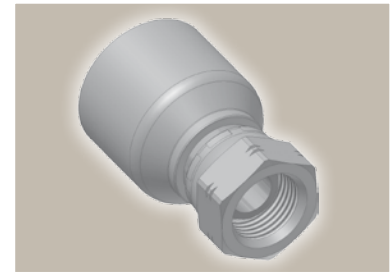
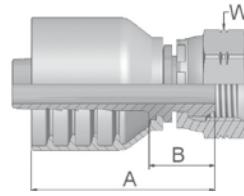

Part Number	Hose I.D.				Thread BSP	A mm	B mm	W mm
	DN	Inch	Size	mm				
19270-6-6	10	3/8	-6	9.5	3/8x19	49	20	22
19270-8-6	10	3/8	-6	9.5	1/2x14	51	22	27
19270-8-8	12	1/2	-8	12.7	1/2x14	57	22	27
19270-10-8	12	1/2	-8	12.7	5/8x14	55	20	30
19270-10-10	16	5/8	-10	15.9	5/8x14	57	21	30
19270-12-10	16	5/8	-10	15.9	3/4x14	61	22	32
19270-12-12	19	3/4	-12	19.1	3/4x14	61	22	32
19270-16-12	19	3/4	-12	19.1	1x11	63	24	41
19270-16-16	25	1	-16	25.4	1x11	76	27	41

B1 Female BSP Parallel Pipe Swivel 45° Elbow (60° Cone)

BS 5200-D – DKR 45°

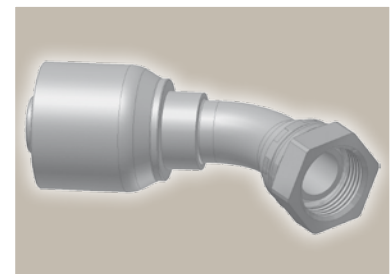
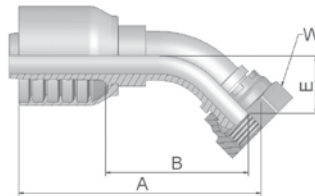

Part Number	Hose I.D.				Thread BSP	A mm	B mm	E mm	W mm
	DN	Inch	Size	mm					
1B170-4-6	10	3/8	-6	9.5	1/4x19	68	39	19	19
1B170-6-6	10	3/8	-6	9.5	3/8x19	67	37	17	22
1B170-8-6	10	3/8	-6	9.5	1/2x14	68	39	19	27
1B170-8-8	12	1/2	-8	12.7	1/2x14	79	45	20	27
1B170-10-8	12	1/2	-8	12.7	5/8x14	78	43	19	30
1B170-10-10	16	5/8	-10	15.9	5/8x14	90	50	24	30
1B170-12-10	16	5/8	-10	15.9	3/4x14	88	49	22	32
1B170-12-12	19	3/4	-12	19.1	3/4x14	96	57	25	32
1B170-16-12	19	3/4	-12	19.1	1x11	95	56	24	41
1B170-16-16	25	1	-16	25.4	1x11	120	75	31	41

Approved **fitting series** for hose types:

Also available in stainless steel. Details can be found in CAT 4400.1/UK

70 CM4SPP

B2 Female BSP Parallel Pipe Swivel 90° Elbow (60° Cone)

BS 5200-B – DKR 90°

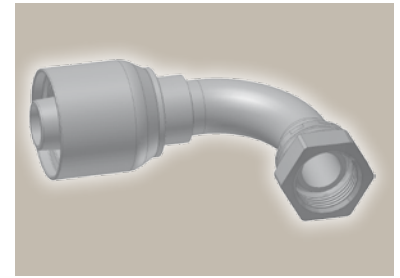
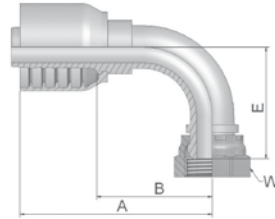

Part Number	Hose I.D.				Thread BSP	A mm	B mm	E mm	W mm
	DN	Inch	Size	mm					
1B270-6-6	10	3/8	-6	9.5	3/8x19	66	37	33	22
1B270-8-6	10	3/8	-6	9.5	1/2x14	66	37	35	27
1B270-8-8	12	1/2	-8	12.7	1/2x14	70	35	39	27
1B270-10-8	12	1/2	-8	12.7	5/8x14	74	39	38	30
1B270-10-10	16	5/8	-10	15.9	5/8x14	81	44	47	30
1B270-12-10	16	5/8	-10	15.9	3/4x14	92	52	59	32
1B270-16-10	16	5/8	-10	15.9	1x11	86	46	44	41
1B270-12-12	19	3/4	-12	19.1	3/4x14	89	50	53	32
1B270-16-12	19	3/4	-12	19.1	1x11	89	49	51	41
1B270-16-16	25	1	-16	25.4	1x11	116	69	69	41

EA BSP Swivel Female with O-Ring (60° Cone)

BS 5200 – ISO 12151-6 – DKOR

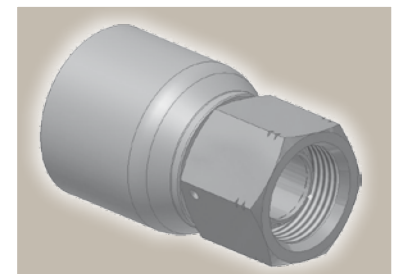
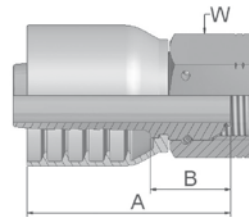

Part Number	Hose I.D.				Thread BSP	A mm	B mm	W mm
	DN	Inch	Size	mm				
1EA70-8-8	12	1/2	-8	12.7	1/2x14	56	21	27
1EA70-12-12	19	3/4	-12	19.1	3/4x14	63	23	32
1EA70-16-16	25	1	-16	25.4	1x11	76	31	41

Fittings with standard O-ring seals can be used for temperatures from -40 °C up to +105 °C.
Find O-rings in section F. Special O-rings are available on request.

Approved **fitting series** for hose types:

Also available in stainless steel. Details can be found in CAT 4400.1/UK

70 CM4SPP

EC BSP Swivel Female with O-Ring 90° Elbow (60° Cone)

BS 5200 – ISO 12151-6 – DKOR 90°

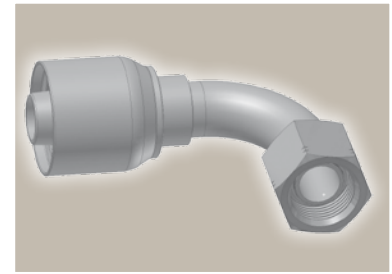
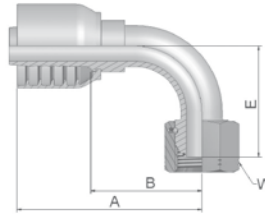

Part Number	Hose I.D.				Thread BSP	A mm	B mm	E mm	W mm
	DN	Inch	Size	mm					
1EC70-8-8	12	1/2	-8	12.7	1/2x14	71	36	40	27
1EC70-12-12	19	3/4	-12	19.1	3/4x14	89	50	55	32
1EC70-16-16	25	1	-16	25.4	1x11	115	68	71	41

Fittings with standard O-ring seals can be used for temperatures from -40 °C up to +105 °C.
Find O-rings in section F. Special O-rings are available on request.

D9 Male BSP Parallel Pipe Rigid – Straight (60° Cone)

BS5200 – AGR

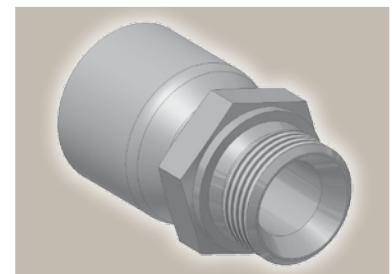
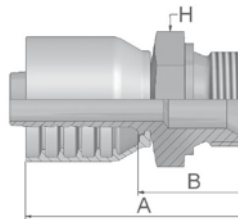

Part Number	Hose I.D.				Thread BSP	A mm	B mm	H mm
	DN	Inch	Size	mm				
1D970-6-6	10	3/8	-6	9.5	3/8x19	57	28	22
1D970-8-6	10	3/8	-6	9.5	1/2x14	60	31	27
1D970-8-8	12	1/2	-8	12.7	1/2x14	62	28	27
1D970-10-8	12	1/2	-8	12.7	5/8x14	70	36	30
1D970-12-8	12	1/2	-8	12.7	3/4x14	69	35	32
1D970-10-10	16	5/8	-10	15.9	5/8x14	75	36	30
1D970-12-10	16	5/8	-10	15.9	3/4x14	72	35	32
1D970-12-12	19	3/4	-12	19.1	3/4x14	70	30	32
1D970-16-12	19	3/4	-12	19.1	1x11	77	38	41
1D970-16-16	25	1	-16	25.4	1x11	85	40	41

Approved **fitting series** for hose types:

Also available in stainless steel. Details can be found in CAT 4400.1/UK

70 CM4SPP

01

Male NPTF Pipe Rigid – Straight

SAE J476A / J516 – AGN

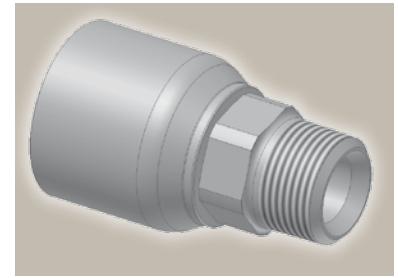
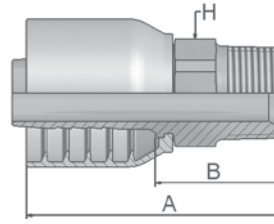

Part Number	Hose I.D.				Thread NPTF	A mm	B mm	H mm
	DN	Inch	Size	mm				
10170-6-6-SM	10	3/8	-6	9.5	3/8x18	60	31	19
10170-12-8-SM	12	1/2	-8	12.7	3/4x14	68	33	27
10170-8-10-SM	16	5/8	-10	15.9	1/2x14	75	38	24
10170-12-10-SM	16	5/8	-10	15.9	3/4x14	71	34	27
10170-12-12-SM	19	3/4	-12	19.1	3/4x14	79	39	27
10170-16-12-SM	19	3/4	-12	19.1	1x11-1/2	79	39	36
10170-16-16-SM	25	1	-16	25.4	1x11-1/2	93	46	36

03

Male JIC 37° – Rigid Straight

ISO12151-5-S – AGJ

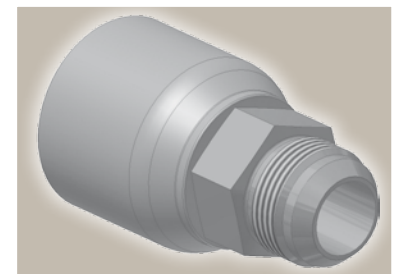
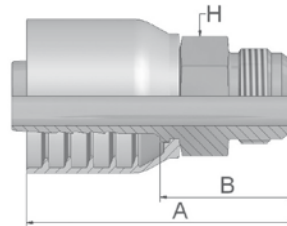

Part Number	Hose I.D.				Thread UNF	A mm	B mm	H mm
	DN	Inch	Size	mm				
10370-6-6-SM	10	3/8	-6	9.5	9/16x18	60	31	19
10370-8-6-SM	10	3/8	-6	9.5	3/4x16	59	29	19
10370-8-8-SM	12	1/2	-8	12.7	3/4x16	68	33	22
10370-10-8-SM	12	1/2	-8	12.7	7/8x14	67	32	24
10370-12-8-SM	12	1/2	-8	12.7	1-1/16x12	71	36	27
10370-10-10-SM	16	5/8	-10	15.9	7/8x14	75	38	24
10370-12-10-SM	16	5/8	-10	15.9	1-1/16x12	75	36	27
10370-12-12-SM	19	3/4	-12	19.1	1-1/16x12	82	42	27
10370-16-12-SM	19	3/4	-12	19.1	1-5/16x12	77	38	36
10370-16-16-SM	25	1	-16	25.4	1-5/16x12	94	47	36

SM: Metric Hexagon

Approved **fitting series** for hose types:

Also available in stainless steel. Details can be found in CAT 4400.1/UK

70 CM4SPP

06 Female JIC 37° – Swivel Straight

ISO12151-5-SWS – DKJ

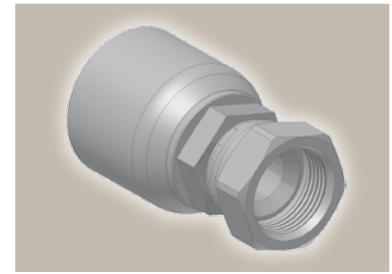
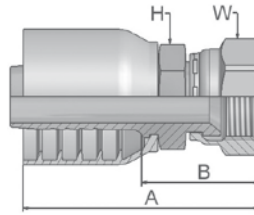

Part Number	Hose I.D.				Thread UNF	A mm	B mm	H mm	W mm
	DN	Inch	Size	mm					
10670-6-6-SM	10	3/8	-6	9.5	9/16x18	58	29	17	19
10670-8-6-SM	10	3/8	-6	9.5	3/4x16	61	32	19	22
10670-10-6-SM*	10	3/8	-6	9.5	7/8x14	64	35	22	27
10670-8-8-SM*	12	1/2	-8	12.7	3/4x16	67	32	22	22
10670-10-8-SM*	12	1/2	-8	12.7	7/8x14	70	35	22	27
10670-12-8-SM	12	1/2	-8	12.7	1-1/16x12	71	36	27	32
10670-8-10-SM*	16	5/8	-10	15.9	3/4x16	73	36	24	22
10670-12-10-SM	16	5/8	-10	15.9	1-1/16x12	79	39	27	32
10670-12-12-SM	19	3/4	-12	19.1	1-1/16x12	80	41	27	32
10670-14-12-SM	19	3/4	-12	19.1	1-3/16x12	81	42	32	36
10670-16-12-SM	19	3/4	-12	19.1	1-5/16x12	84	45	32	41
10670-12-16-SM	25	1	-16	25.4	1-1/16x12	89	44	36	32
10670-16-16-SM	25	1	-16	25.4	1-5/16x12	92	47	36	41
10670-20-16-SM	25	1	-16	25.4	1-5/8x12	98	52	41	50

* These fittings contain a dual seat that accepts both JIC (37°) and SAE (45°) male configurations. The other sizes accept the JIC (37°) male configurations only.

SM: Metric Hexagon

Approved **fitting series** for hose types:

Also available in stainless steel. Details can be found in CAT 4400.1/UK

70 CM4SPP

37 Female JIC 37° – Swivel 45° Elbow

ISO 12151-5-SWE 45° – DKJ 45°

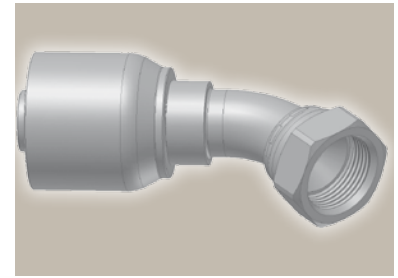
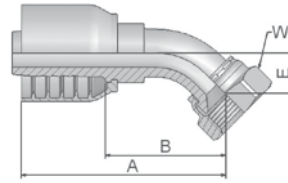

Part Number	Hose I.D.				Thread UNF	A mm	B mm	E mm	W mm
	DN	Inch	Size	mm					
13770-6-6-SM	10	3/8	-6	9.5	9/16x18	61	31	10	19
13770-8-6-SM*	10	3/8	-6	9.5	3/4x16	70	41	14	22
13770-8-8-SM*	12	1/2	-8	12.7	3/4x16	73	38	14	22
13770-10-8-SM*	12	1/2	-8	12.7	7/8x14	78	43	17	27
13770-8-10-SM*	16	5/8	-10	15.9	3/4x16	78	39	15	22
13770-10-10-SM*	16	5/8	-10	15.9	7/8x14	83	44	17	27
13770-12-10-SM	16	5/8	-10	15.9	1-1/16x12	85	48	21	32
13770-12-12-SM	19	3/4	-12	19.1	1-1/16x12	91	52	20	32
13770-16-12-SM	19	3/4	-12	19.1	1-5/16x12	95	56	24	41
13770-16-16-SM	25	1	-16	25.4	1-5/16x12	111	66	24	41
13770-20-16-SM	25	1	-16	25.4	1-5/8x12	113	67	26	50

* These fittings contain a dual seat that accepts both JIC (37°) and SAE (45°) male configurations. The other sizes accept the JIC (37°) male configurations only.

39/3W Female JIC 37° SAE 45° – Dual Flare Swivel Female 90° Elbow

ISO 12151-5-SWES – DKJ 90°

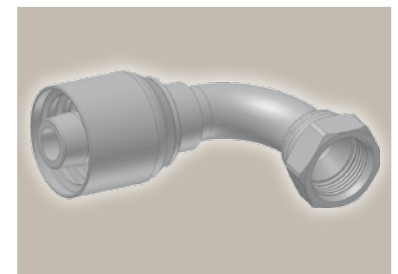
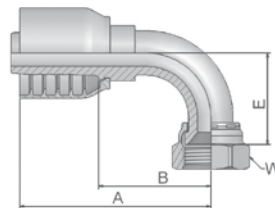

Part Number	Hose I.D.				Thread UNF	A mm	B mm	E mm	W mm
	DN	Inch	Size	mm					
13970-6-6-SM	10	3/8	-6	9.5	9/16x18	57	28	23	19
13W70-8-6-SM	10	3/8	-6	9.5	3/4x16	64	35	28	22
13970-6-8-SM	12	1/2	-8	12.7	9/16x18	64	29	22	19
13970-8-8-SM*	12	1/2	-8	12.7	3/4x16	68	33	28	22
13970-10-8-SM*	12	1/2	-8	12.7	7/8x14	74	39	32	27
13970-8-10-SM*	16	5/8	-10	15.9	3/4x16	74	34	28	22
13970-10-10-SM*	16	5/8	-10	15.9	7/8x14	80	41	33	27
13970-12-10-SM	16	5/8	-10	15.9	1-1/16x12	88	48	47	32
13970-12-12-SM	19	3/4	-12	19.1	1-1/16x12	89	50	48	32
13970-16-12-SM	19	3/4	-12	19.1	1-5/16x12	89	50	51	41
13970-12-16-SM	25	1	-16	25.4	1-1/16x12	99	54	46	32
13970-16-16-SM	25	1	-16	25.4	1-5/16x12	109	64	56	41
13970-20-16-SM	25	1	-16	25.4	1-5/8x12	109	64	62	50

* These fittings contain a dual seat that accepts both JIC (37°) and SAE (45°) male configurations. The other sizes accept the JIC (37°) male configurations only.

SM: Metric Hexagon

Approved **fitting series** for hose types:

Also available in stainless steel. Details can be found in CAT 4400.1/UK



15 ISO 6162-1 Flange Straight

ISO 12151-3-S-L – SFL

(21.0 MPa/ 3000 psi)

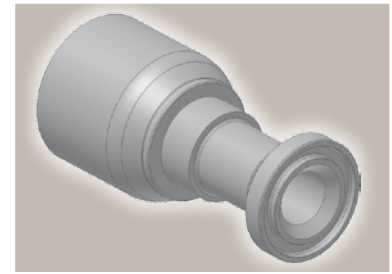
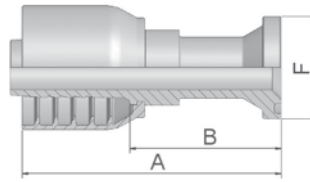

Part Number	Hose I.D.				Flange Inch	A mm	B mm	F mm
	DN	Inch	Size	mm				
11570-8-8	12	1/2	-8	12.7	1/2	89	54	30
11570-10-10	16	5/8	-10	15.9	5/8	116	79	34
11570-12-10	16	5/8	-10	15.9	3/4	69	30	38
11570-12-12	19	3/4	-12	19.1	3/4	98	59	38
11570-16-12	19	3/4	-12	19.1	1	70	31	45
11570-20-12	19	3/4	-12	19.1	1-1/4	75	36	51
11570-12-16	25	1	-16	25.4	3/4	111	66	38
11570-16-16	25	1	-16	25.4	1	108	63	45
11570-20-16	25	1	-16	25.4	1-1/4	83	36	51

Find SAE flanges in section F.

Fittings with standard O-ring seals can be used for temperatures from -40 °C up to +105 °C.

Find O-rings in section F. Special O-rings are available on request.

17 ISO 6162-1 Flange 45° Elbow

ISO 12151-3 – E45 – L – SFL 45°

(21.0 MPa/ 3000 psi)

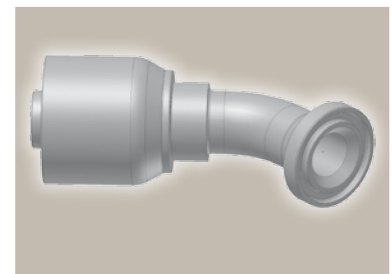
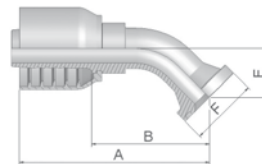

Part Number	Hose I.D.				Flange Inch	A mm	B mm	E mm	F mm
	DN	Inch	Size	mm					
11770-8-8	12	1/2	-8	12.7	1/2	79	44	20	30
11770-10-10	16	5/8	-10	15.9	5/8	104	67	24	34
11770-12-10	16	5/8	-10	15.9	3/4	96	57	26	38
11770-12-12	19	3/4	-12	19.1	3/4	97	58	26	38
11770-16-12	19	3/4	-12	19.1	1	98	58	26	45
11770-16-16	25	1	-16	25.4	1	121	74	32	45
11770-20-16	25	1	-16	25.4	1-1/4	121	76	32	51

Find SAE flanges in section F.

Fittings with standard O-ring seals can be used for temperatures from -40 °C up to +105 °C.

Find O-rings in section F. Special O-rings are available on request.

Approved **fitting series** for hose types:

Also available in stainless steel. Details can be found in CAT 4400.1/UK

70 CM4SPP

19

ISO 6162-1 Flange 90° Elbow

ISO 12151-3 – E-L – SFL 90°

(21.0 MPa/ 3000 psi)

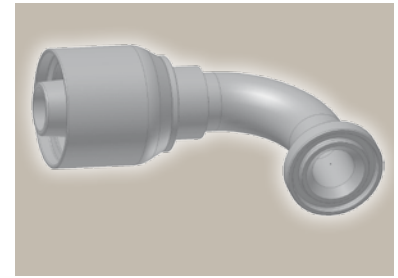
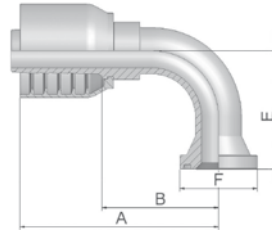

Part Number	Hose I.D.				Flange Inch	A mm	B mm	E mm	F mm
	DN	Inch	Size	mm					
11970-8-8	12	1/2	-8	12.7	1/2	75	40	41	30
11970-12-8	12	1/2	-8	12.7	3/4	77	42	42	38
11970-10-10	16	5/8	-10	15.9	5/8	92	55	55	34
11970-12-12	19	3/4	-12	19.1	3/4	89	50	58	38
11970-16-12	19	3/4	-12	19.1	1	90	50	58	45
11970-16-16	25	1	-16	25.4	1	105	55	61	45
11970-20-16	25	1	-16	25.4	1-1/4	113	68	70	51

Find SAE flanges in section F.

Fittings with standard O-ring seals can be used for temperatures from -40 °C up to +105 °C.

Find O-rings in section F. Special O-rings are available on request.

6A

ISO 6162-2 Flange Straight

ISO 12151-3-S-S – SFS

(42.0 MPa/ 6000 psi)

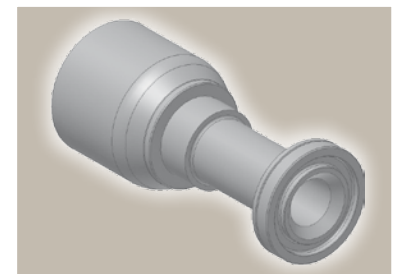
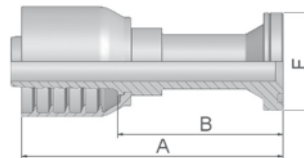

Part Number	Hose I.D.				Flange Inch	A mm	B mm	F mm
	DN	Inch	Size	mm				
16A70-8-8	12	1/2	-8	12.7	1/2	89	54	32
16A70-12-8	12	1/2	-8	12.7	3/4	74	34	41
16A70-8-10	16	5/8	-10	15.9	1/2	107	68	32
16A70-12-10	16	5/8	-10	15.9	3/4	72	35	41
16A70-8-12	19	3/4	-12	19.1	1/2	107	67	32
16A70-12-12	19	3/4	-12	19.1	3/4	105	66	41
16A70-16-12	19	3/4	-12	19.1	1	79	39	48
16A70-12-16	25	1	-16	25.4	3/4	127	82	41
16A70-16-16	25	1	-16	25.4	1	127	82	48
16A70-20-16	25	1	-16	25.4	1-1/4	99	47	54

Find SAE flanges in section F.

Fittings with standard O-ring seals can be used for temperatures from -40 °C up to +105 °C.

Find O-rings in section F. Special O-rings are available on request.

Approved **fitting series** for hose types:

Also available in stainless steel. Details can be found in CAT 4400.1/UK



6F ISO 6162-2 Flange 45° Elbow – Heavy Series

ISO 12151-3 – E45-S – SFS 45°

(42.0 MPa/ 6000 psi)

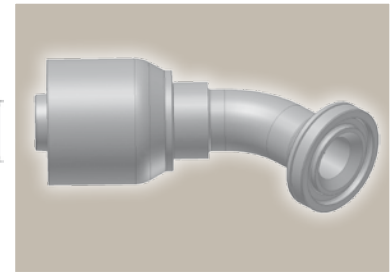
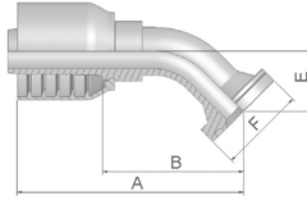

Part Number	Hose I.D.				Flange Inch	A mm	B mm	E mm	F mm
	DN	Inch	Size	mm					
16F70-8-8	12	1/2	-8	12.7	1/2	81	46	19	31.75
16F70-12-8	12	1/2	-8	12.7	3/4	90	55	26	41
16F70-8-10	16	5/8	-10	15.9	1/2	92	53	26	32
16F70-12-10	16	5/8	-10	15.9	3/4	92	55	26	41
16F70-8-12	19	3/4	-12	19.1	1/2	94	54	26	32
16F70-12-12	19	3/4	-12	19.1	3/4	105	66	26	41
16F70-16-12	19	3/4	-12	19.1	1	101	62	26	48
16F70-12-16	25	1	-16	25.4	3/4	118	73	27	41
16F70-16-16	25	1	-16	25.4	1	119	74	32	48
16F70-20-16	25	1	-16	25.4	1-1/4	120	73	32	54

Find SAE flanges in section F.

Fittings with standard O-ring seals can be used for temperatures from -40 °C up to +105 °C.

Find O-rings in section F. Special O-rings are available on request.

6N ISO 6162-2 Flange 90° Elbow

ISO 12151-3 – E-S – SFS 90°

(42.0 MPa/ 6000 psi)

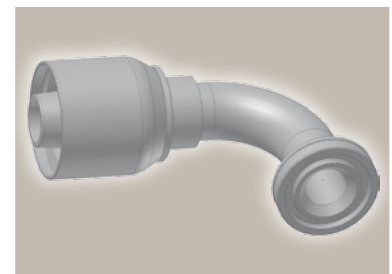
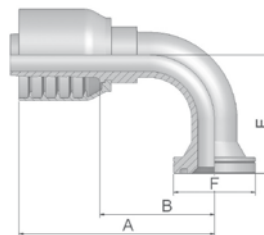

Part Number	Hose I.D.				Flange Inch	A mm	B mm	E mm	F mm
	DN	Inch	Size	mm					
16N70-8-8	12	1/2	-8	12.7	1/2	74	39	41	32
16N70-12-8	12	1/2	-8	12.7	1/2	79	44	45	41
16N70-8-10	16	5/8	-10	15.9	1/2	95	56	54	32
16N70-12-10	16	5/8	-10	15.9	3/4	94	55	54	41
16N70-16-10	16	5/8	-10	15.9	1	86	46	54	48
16N70-8-12	19	3/4	-12	19.1	1/2	81	42	54	32
16N70-12-12	19	3/4	-12	19.1	3/4	98	59	54	41
16N70-16-12	19	3/4	-12	19.1	1	92	53	58	48
16N70-12-16	25	1	-16	25.4	3/4	113	66	57	41
16N70-16-16	25	1	-16	25.4	1	111	64	70	48

Find SAE flanges in section F.

Fittings with standard O-ring seals can be used for temperatures from -40 °C up to +105 °C.

Find O-rings in section F. Special O-rings are available on request.

Approved **fitting series** for hose types:

Also available in stainless steel. Details can be found in CAT 4400.1/UK

70 CM4SPP

Steck0®

Page Cd-1

S0

Cd-1



Steck0® fitting
Straight

Super Steck0®

Page Cd-1

A0

Cd-1



Super Steck0® fitting

DIN – Metric

Page Cd-2 – Cd-3

C9

Cd-2



Female Metric 24° – Swivel
Heavy Series with O-Ring
Straight
ISO 12151-2-SWS-S – DKOS

0C

Cd-2



Female Metric 24° – Swivel
Heavy Series with O-Ring
45° Elbow
ISO 12151-2 – SWE 45°-S – DKOS 45°

1C

Cd-3



Female Metric 24° – Swivel
Heavy Series with O-Ring
90° Elbow
ISO 12151-2-SWE-S – DKOS 90°

D2

Cd-3

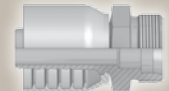

Male Metric 24° – Rigid
Heavy Series – Straight
ISO 12151-2-S-S – CES

BSP

Page Cd-4 – Cd-5

92

Cd-4

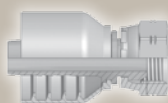

Female BSP Parallel Pipe
Swivel – Straight (60° Cone)
BS5200-A – DKR

B1

Cd-4



Female BSP Parallel Pipe
Swivel
45° Elbow (60° Cone)
BS 5200-D – DKR 45°

B2

Cd-5



Female BSP Parallel Pipe
Swivel
90° Elbow (60° Cone)
BS 5200-B – DKR 90°

D9

Cd-5

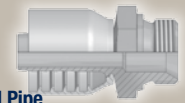

Male BSP Parallel Pipe
Rigid – Straight (60° Cone)
BS5200 – AGR

SAE

Page Cd-6 – Cd-8

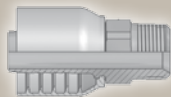
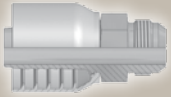
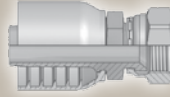
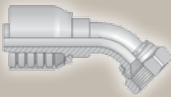
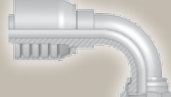
<p>01 Cd-6</p>  <p>Male NPTF Pipe Rigid – Straight SAE J476A / J516 – AGN</p>	<p>03 Cd-6</p>  <p>Male JIC 37° – Rigid Straight ISO12151-5-S – AGJ</p>	<p>06 Cd-7</p>  <p>Female JIC 37° – Swivel Straight ISO12151-5-SWS – DKJ</p>	<p>37 Cd-7</p>  <p>Female JIC 37° – Swivel 45° Elbow ISO 12151-5-SWE 45° – DKJ 45°</p>
<p>39 Cd-8</p>  <p>Female JIC 37° – Swivel 90° Elbow ISO 12151-5-SWES – DKJ 90°</p>			

Flange

Page Cd-8 – Cd-13

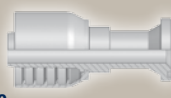
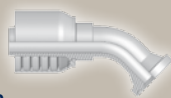
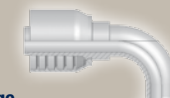
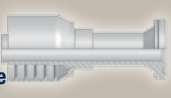
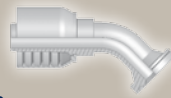
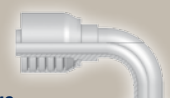
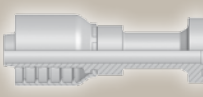
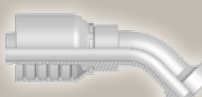
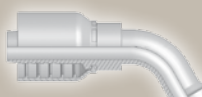
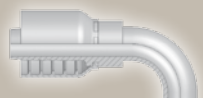
<p>15/4A Cd-8</p>  <p>ISO 6162-1 Flange Straight ISO 12151-3-S-L – SFL (35.0 MPa/ 5000 psi)</p>	<p>17/4F Cd-8</p>  <p>ISO 6162-1 Flange 45° Elbow ISO 12151-3 – E45S – L – SFL 45° (35.0 MPa/ 5000 psi)</p>	<p>19/4N Cd-9</p>  <p>ISO 6162-1 Flange 90° Elbow ISO 12151-3-E-L – SFL 90° (35.0 MPa/ 5000 psi)</p>
<p>6A Cd-9</p>  <p>ISO 6162-2 Flange Straight ISO 12151-3-S-S – SFS (42.0 MPa/ 6000 psi)</p>	<p>6F Cd-10</p>  <p>ISO 6162-2 Flange 45° Elbow – Heavy Series ISO 12151-3 – E45-S – SFS 45° (42.0 MPa/ 6000 psi)</p>	<p>6N Cd-10</p>  <p>ISO 6162-2 Flange 90° Elbow ISO 12151-3 – E-S – SFS 90° (42.0 MPa/ 6000 psi)</p>
<p>XA Cd-12</p>  <p>Caterpillar® Flange Straight</p>	<p>XF Cd-12</p>  <p>Caterpillar® Flange 45° Elbow</p>	<p>XG Cd-13</p>  <p>Caterpillar® Flange 60° Elbow</p>
<p>XN Cd-13</p>  <p>Caterpillar® Flange 90° Elbow</p>		

S0 SteckO® fitting

Straight

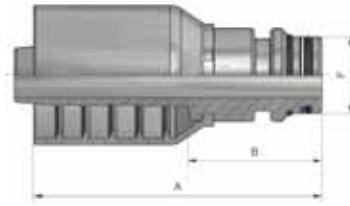

Part Number	Hose I.D.				A mm	B mm	F mm
	DN	Inch	Size	mm			
1S073-12-12	19	3/4	-12	19.1	85	37	24
1S073-16-16	25	1	-16	25.4	96	45	31
1S073-20-20	31	1 1/4	-20	31.8	117	53	38
1S073-24-24	38	1 1/2	-24	38.1	116	54	47
1S073-32-32	51	2	-32	50.8	127	55	56

A0 Super SteckO® fitting

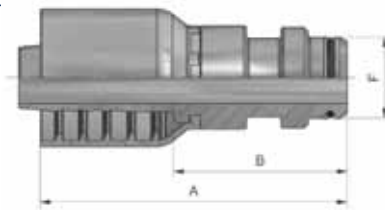

Part Number	Hose I.D.				A mm	B mm	F mm
	DN	Inch	Size	mm			
1A073-12-12	19	3/4	-12	19.1	93	46	22
1A073-16-16	25	1	-16	25.4	116	66	31
1A073-20-20	31	1 1/4	-20	31.8	134	70	38
1A073-24-24	38	1 1/2	-24	38.1	149	75	44
1A073-32-32	51	2	-32	50.8	157	78	50

Approved **fitting series** for hose types:

73 CM4SHP | 731TC

C9 Female Metric 24° – Swivel Heavy Series with O-Ring Straight

ISO 12151-2-SWS-S – DKOS

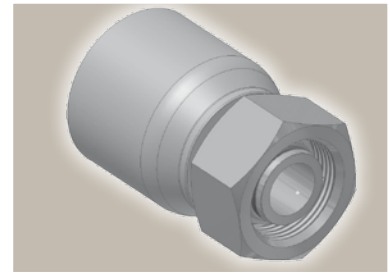
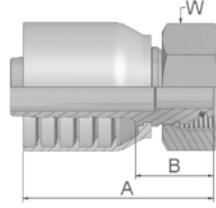

Part Number	Hose I.D.				Thread metric	Tube O.D. mm	A mm	B mm	W mm
	DN	Inch	Size	mm					
1C973-20-12	19	3/4	-12	19.1	M30x2	20	81	33	36
1C973-25-12	19	3/4	-12	19.1	M36x2	25	79	31	46
1C973-25-16	25	1	-16	25.4	M36x2	25	87	36	46
1C973-30-16	25	1	-16	25.4	M42x2	30	87	36	50
1C973-30-20	31	1 1/4	-20	31.8	M42x2	30	106	42	50
1C973-38-20	31	1 1/4	-20	31.8	M52x2	38	101	37	60
1C973-38-24	38	1 1/2	-24	38.1	M52x2	38	105	42	60

Fittings with standard O-ring seals can be used for temperatures from -40 °C up to +105 °C.
Find O-rings in section F. Special O-rings are available on request.

OC Female Metric 24° – Swivel Heavy Series with O-Ring 45° Elbow

ISO 12151-2 – SWE 45°-S – DKOS 45°

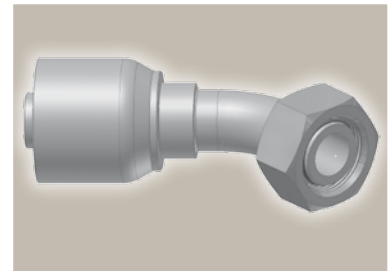
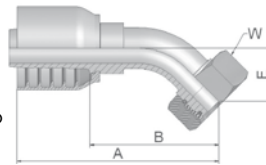

Part Number	Hose I.D.				Thread metric	Tube O.D. mm	A mm	B mm	E mm	W mm
	DN	Inch	Size	mm						
10C73-20-12	19	3/4	-12	19.1	M30x2	20	112	64	28	36
10C73-25-12	19	3/4	-12	19.1	M36x2	25	112	64	29	46
10C73-30-16	25	1	-16	25.4	M42x2	30	131	81	34	50
10C73-38-20	31	1 1/4	-20	31.8	M52x2	38	161	97	37	60

Fittings with standard O-ring seals can be used for temperatures from -40 °C up to +105 °C.
Find O-rings in section F. Special O-rings are available on request.

Approved **fitting series** for hose types:

73 CM4SHP | 731TC

1C Female Metric 24° – Swivel Heavy Series with O-Ring 90° Elbow

ISO 12151-2-SWE-S – DKOS 90°

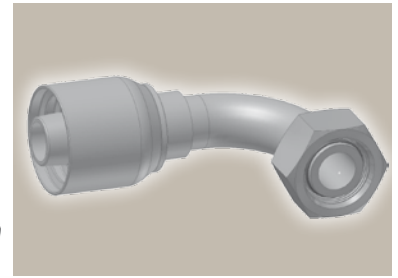
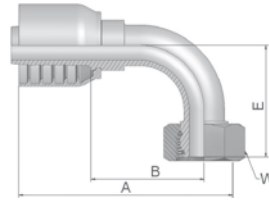

Part Number	Hose I.D.				Thread metric	Tube O.D. mm	A mm	B mm	E mm	W mm
	DN	Inch	Size	mm						
11C73-20-12	19	3/4	-12	19.1	M30x2	20	101	53	57	36
11C73-25-12	19	3/4	-12	19.1	M36x2	25	101	53	59	46
11C73-25-16	25	1	-16	25.4	M36x2	25	122	71	70	46
11C73-30-16	25	1	-16	25.4	M42x2	30	122	71	73	50
11C73-30-20	31	1 1/4	-20	31.8	M42x2	30	138	73	74	50
11C73-38-20	31	1 1/4	-20	31.8	M52x2	38	151	87	78	60

Fittings with standard O-ring seals can be used for temperatures from -40 °C up to +105 °C.
Find O-rings in section F. Special O-rings are available on request.

D2 Male Metric 24° – Rigid Heavy Series – Straight

ISO 12151-2-S-S – CES

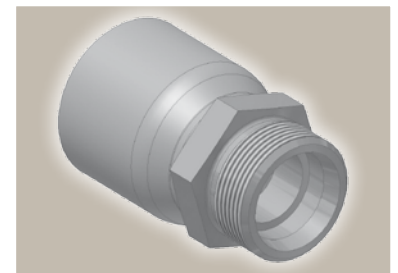
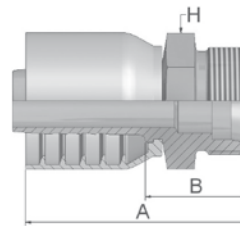

Part Number	Hose I.D.				Thread metric	Tube O.D. mm	A mm	B mm	H mm
	DN	Inch	Size	mm					
1D273-20-12	19	3/4	-12	19.1	M30x2	20	84	35	30
1D273-25-12	19	3/4	-12	19.1	M36x2	25	86	38	36
1D273-30-16	25	1	-16	25.4	M42x2	30	94	42	46
1D273-38-20	31	1 1/4	-20	31.8	M52x2	38	112	46	55



Approved **fitting series** for hose types:

73 CM4SHP | 731TC

92 Female BSP Parallel Pipe Swivel – Straight (60° Cone)

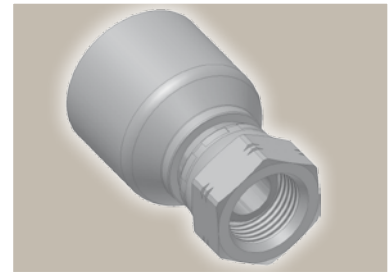
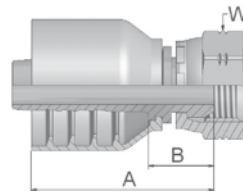
BS5200-A – DKR





Part Number	 Hose I.D.				 Thread BSP	A mm	B mm	 W mm
	DN	Inch	Size	mm				
19273-12-12	19	3/4	-12	19.1	3/4x14	77	29	32
19273-16-16	25	1	-16	25.4	1x11	89	38	41
19273-20-20	31	1 1/4	-20	31.8	1-1/4x11	101	37	50
19273-24-24	38	1 1/2	-24	38.1	1-1/2x11	100	37	55
19273-32-32	51	2	-32	50.8	2x11	113	38	70

B1 Female BSP Parallel Pipe Swivel 45° Elbow (60° Cone)

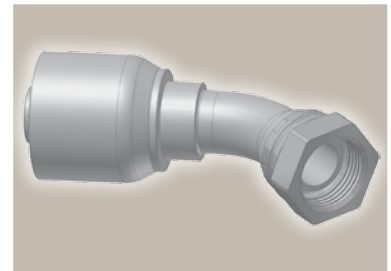
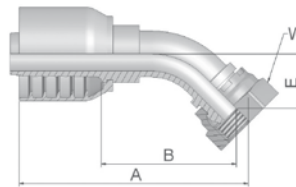
BS 5200-D – DKR 45°



Part Number	 Hose I.D.				 Thread BSP	A mm	B mm	E mm	 W mm
	DN	Inch	Size	mm					
1B173-12-12	19	3/4	-12	19.1	3/4x14	110	62	26	32
1B173-16-16	25	1	-16	25.4	1x11	136	84	39	41
1B173-20-20	31	1 1/4	-20	31.8	1-1/4x11	168	104	43	50
1B173-24-24	38	1 1/2	-24	38.1	1-1/2x11	186	123	52	55
1B173-32-32	51	2	-32	50.8	2x11	249	177	70	70

Approved **fitting series** for hose types:

 73 CM4SHP | 731TC

B2 Female BSP Parallel Pipe Swivel 90° Elbow (60° Cone)

BS 5200-B – DKR 90°

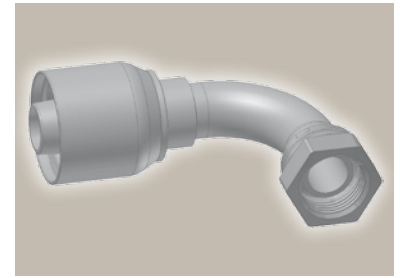
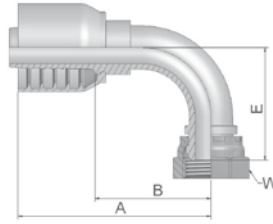

Part Number	Hose I.D.				Thread BSP	A mm	B mm	E mm	W mm
	DN	Inch	Size	mm					
1B273-12-12	19	3/4	-12	19.1	3/4x14	106	58	55	32
1B273-16-16	25	1	-16	25.4	1x11	121	70	76	41
1B273-20-20	31	1 1/4	-20	31.8	1-1/4x11	151	87	80	50
1B273-24-24	38	1 1/2	-24	38.1	1-1/2x11	166	103	103	55
1B273-32-32	51	2	-32	50.8	2x11	229	157	121	70

D9 Male BSP Parallel Pipe Rigid – Straight (60° Cone)

BS5200 – AGR

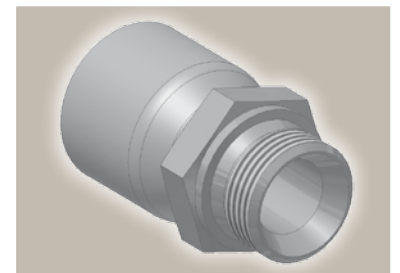
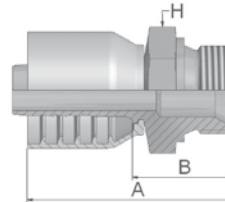

Part Number	Hose I.D.				Thread BSP	A mm	B mm	H mm
	DN	Inch	Size	mm				
1D973-12-12	19	3/4	-12	19.1	3/4x14	87	39	32
1D973-16-16	25	1	-16	25.4	1x11	96	43	41
1D973-20-20	31	1 1/4	-20	31.8	1-1/4x11	113	49	50
1D973-24-24	38	1 1/2	-24	38.1	1-1/2x11	114	51	55
1D973-32-32	51	2	-32	50.8	2x11	129	58	70



Approved **fitting series** for hose types:

73 CM4SHP | 731TC

01 Male NPTF Pipe Rigid – Straight

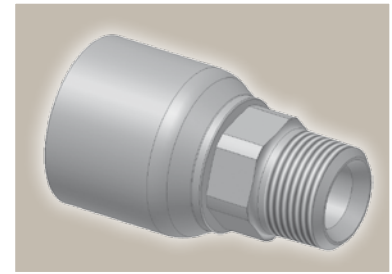
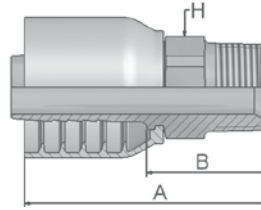
SAE J476A / J516 – AGN





Part Number	 Hose I.D.				 Thread NPTF	A mm	B mm	 H	
	DN	Inch	Size	mm				mm	Inch
10173-12-12-SM	19	3/4	-12	19.1	3/4x14	90	42	30	
10173-16-16-SM	25	1	-16	25.4	1x11-1/2	100	50	36	
10173-20-20-SM	31	1 1/4	-20	31.8	1-1/4x11-1/2	125	61	46	
10173-24-24	38	1 1/2	-24	38.1	1-1/2x11-1/2	124	61	50	
10173-32-32	51	2	-32	50.8	2x11-1/2	141	73	2 1/2	

03 Male JIC 37° – Rigid Straight

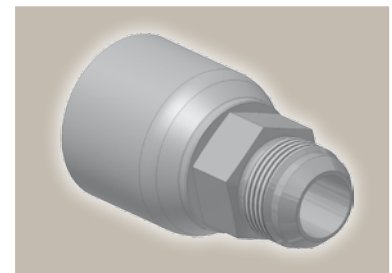
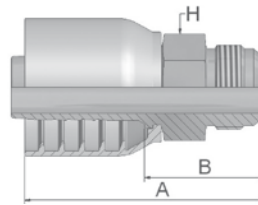
ISO12151-5-S – AGJ



Part Number	 Hose I.D.				 Thread UNF	A mm	B mm	 H	
	DN	Inch	Size	mm				mm	mm
10373-12-12-SM	19	3/4	-12	19.1	1-1/16x12	89	41	30	
10373-16-12	19	3/4	-12	19.1	1-5/16x12	91	43	36	
10373-16-16-SM	25	1	-16	25.4	1-5/16x12	97	47	36	
10373-20-16	25	1	-16	25.4	1-5/8x12	102	52	46	
10373-20-20-SM	31	1 1/4	-20	31.8	1-5/8x12	118	54	46	
10373-24-20	31	1 1/4	-20	31.8	1-7/8x12	118	54	50	
10373-24-24-SM	38	1 1/2	-24	38.1	1-7/8x12	122	59	50	
10373-32-32-SM	51	2	-32	50.8	2-1/2x12	143	72	65	

Approved **fitting series** for hose types:

SM: Metric Hexagon

 73 CM4SHP | 731TC

06 Female JIC 37° – Swivel Straight

ISO12151-5-SWS – DKJ

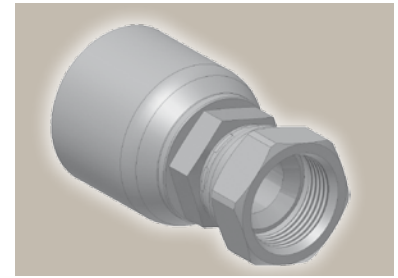
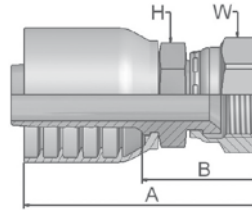

Part Number	Hose I.D.				Thread UNF	A mm	B mm	H		W	
	DN	Inch	Size	mm				mm	Inch	mm	Inch
10673-12-12-SM	19	3/4	-12	19.1	1-1/16x12	93	45	30		32	
10673-16-12	19	3/4	-12	19.1	1-5/16x12	95	47	1 3/8		1 1/2	
10673-16-16-SM	25	1	-16	25.4	1-5/16x12	103	52	36		41	
10673-20-16	25	1	-16	25.4	1-5/8x12	108	60	1 3/4		2	
10673-16-20-SM	31	1 1/4	-20	31.8	1-5/16x12	116	52	46		41	
10673-20-20-SM	31	1 1/4	-20	31.8	1-5/8x12	125	61	46		50	
10673-24-20-SM	31	1 1/4	-20	31.8	1-7/8x12	130	66	50		60	
10673-24-24-SM	38	1 1/2	-24	38.1	1-7/8x12	128	66	50		60	

37 Female JIC 37° – Swivel 45° Elbow

ISO 12151-5-SWE 45° – DKJ 45°

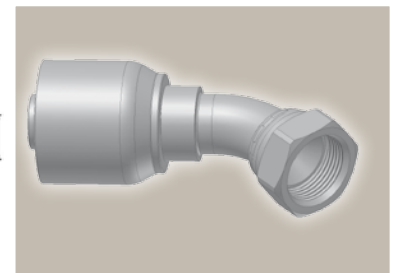
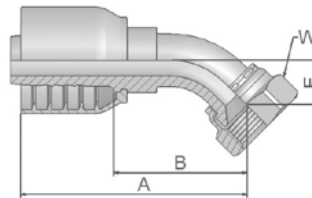

Part Number	Hose I.D.				Thread UNF	A mm	B mm	E mm	W	
	DN	Inch	Size	mm					mm	mm
13773-12-12-SM	19	3/4	-12	19.1	1-1/16x12	104	56	22		32
13773-16-12	19	3/4	-12	19.1	1-5/16x12	107	59	24		41
13773-16-16-SM	25	1	-16	25.4	1-5/16x12	119	69	24		41
13773-20-16-SM	25	1	-16	25.4	1-5/8x12	143	92	47		50
13773-20-20-SM	31	1 1/4	-20	31.8	1-5/8x12	172	108	47		50
13773-24-24-SM	38	1 1/2	-24	38.1	1-7/8x12	194	132	58		60
13773-32-32-SM	51	2	-32	50.8	2-1/2x12	251	179	72		75

Approved **fitting series** for hose types:



SM: Metric Hexagon

73 CM4SHP 731TC

39 Female JIC 37° – Swivel 90° Elbow

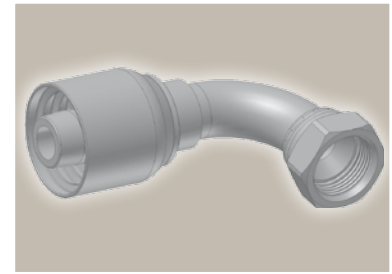
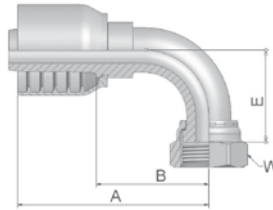
ISO 12151-5-SWES – DKJ 90°



Part Number	 Hose I.D.				 Thread UNF	A mm	B mm	E mm	 W mm
	DN	Inch	Size	mm					
13973-12-12-SM	19	3/4	-12	19.1	1-1/16x12	101	53	48	32
13973-16-12-SM	19	3/4	-12	19.1	1-5/16x12	101	53	56	41
13973-16-16-SM	25	1	-16	25.4	1-5/16x12	118	67	56	41
13973-20-16	25	1	-16	25.4	1-5/8x12	118	67	85	50
13973-20-20-SM	31	1 1/4	-20	31.8	1-5/8x12	151	87	85	50
13973-24-24-SM	38	1 1/2	-24	38.1	1-7/8x12	194	119	102	60
13973-32-32-SM	51	2	-32	50.8	2-1/2x12	229	157	152	75

Approved **fitting series** for hose types:

SM: Metric Hexagon

73 CM4SHP | 731TC

15/4A ISO 6162-1 Flange Straight

ISO 12151-3-S-L – SFL

(35.0 MPa/ 5000 psi)

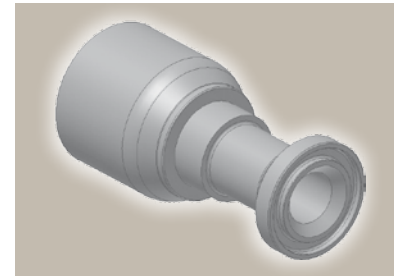
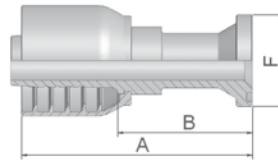

Part Number	Hose I.D.				Flange Inch	A mm	B mm	F mm
	DN	Inch	Size	mm				
11573-12-12	19	3/4	-12	19.1	3/4	110	62	38
11573-16-12	19	3/4	-12	19.1	1	91	43	45
11573-16-16	25	1	-16	25.4	1	117	67	45
14A73-20-16	25	1	-16	25.4	1-1/4	85	34	51
11573-16-20	31	1 1/4	-20	31.8	1	133	69	45
14A73-20-20	31	1 1/4	-20	31.8	1-1/4	141	77	51
14A73-24-20	31	1 1/4	-20	31.8	1-1/2	104	40	60
14A73-24-24	38	1 1/2	-24	38.1	1-1/2	166	103	60
14A73-32-24	38	1 1/2	-24	38.1	2	113	50	71
14A73-32-32	51	2	-32	50.8	2	220	148	71

Find SAE flanges in section F.

Fittings with standard O-ring seals can be used for temperatures from -40 °C up to +105 °C.

Find O-rings in section F. Special O-rings are available on request.

17/4F ISO 6162-1 Flange 45° Elbow

ISO 12151-3 – E45S – L – SFL 45°

(35.0 MPa/ 5000 psi)

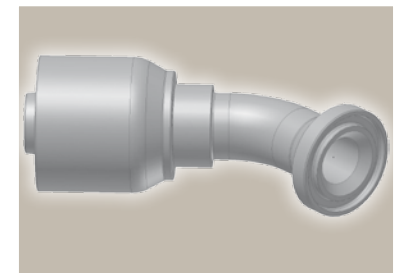
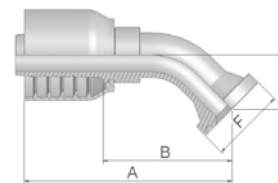

Part Number	Hose I.D.				Flange Inch	A mm	B mm	E mm	F mm
	DN	Inch	Size	mm					
11773-12-12	19	3/4	-12	19.1	3/4	119	71	27	38
11773-16-12	19	3/4	-12	19.1	1	109	64	26	44
11773-16-16	25	1	-16	25.4	1	127	77	32	45
14F73-20-16	25	1	-16	25.4	1-1/4	136	85	32	51
14F73-20-20	31	1 1/4	-20	31.8	1-1/4	160	96	35	51
14F73-24-20	31	1 1/4	-20	31.8	1-1/2	162	102	38	60
14F73-24-24	38	1 1/2	-24	38.1	1-1/2	178	115	44	60
14F73-32-24	38	1 1/2	-24	38.1	2	177	114	43	71

Find SAE flanges in section F.

Fittings with standard O-ring seals can be used for temperatures from -40 °C up to +105 °C.

Find O-rings in section F. Special O-rings are available on request.

Approved **fitting series** for hose types:

73 CM4SHP 731TC

19/4N ISO 6162-1 Flange 90° Elbow

ISO 12151-3-E-L – SFL 90°

(35.0 MPa/ 5000 psi)

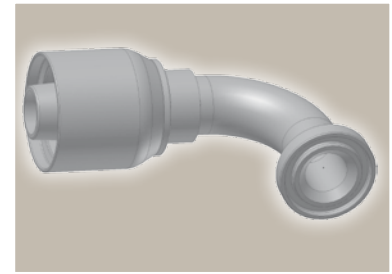
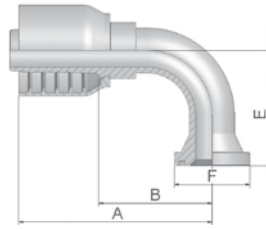

Part Number	Hose I.D.				Flange Inch	A mm	B mm	E mm	F mm
	DN	Inch	Size	mm					
11973-12-12	19	3/4	-12	19.1	3/4	109	61	58	38
11973-16-12	19	3/4	-12	19.1	1	102	54	58	45
11973-12-16	25	1	-16	25.4	3/4	111	61	72	38
11973-16-16	25	1	-16	25.4	1	118	67	70	45
14N73-20-16	25	1	-16	25.4	1-1/4	128	78	68	51
14N73-20-20	31	1 1/4	-20	31.8	1-1/4	155	91	90	51
14N73-24-20	31	1 1/4	-20	31.8	1-1/2	155	91	90	60
14N73-24-24	38	1 1/2	-24	38.1	1-1/2	166	103	104	60
14N73-32-24	38	1 1/2	-24	38.1	2	166	103	92	71
14N73-32-32	51	2	-32	50.8	2	220	148	133	71

Find SAE flanges in section F.

Fittings with standard O-ring seals can be used for temperatures from -40 °C up to +105 °C.

Find O-rings in section F. Special O-rings are available on request.

6A ISO 6162-2 Flange Straight

ISO 12151-3-S-S – SFS

(42.0 MPa/ 6000 psi)

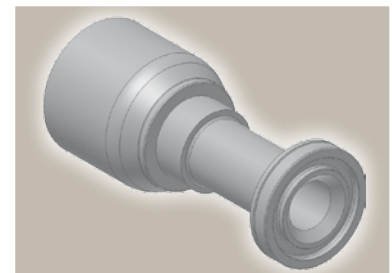
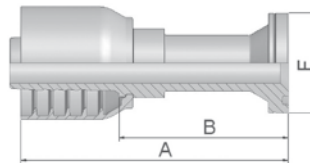

Part Number	Hose I.D.				Flange Inch	A mm	B mm	F mm
	DN	Inch	Size	mm				
16A73-12-12	19	3/4	-12	19.1	3/4	130	82	41
16A73-16-12	19	3/4	-12	19.1	1	135	87	48
16A73-12-16	25	1	-16	25.4	3/4	136	85	41
16A73-16-16	25	1	-16	25.4	1	131	81	48
16A73-20-16	25	1	-16	25.4	1-1/4	100	50	54
16A73-16-20	31	1 1/4	-20	31.8	1	149	85	48
16A73-20-20	31	1 1/4	-20	31.8	1-1/4	149	85	54
16A73-24-20	31	1 1/4	-20	31.8	1-1/2	121	57	64
16A73-20-24	38	1 1/2	-24	38.1	1-1/4	158	96	54
16A73-24-24	38	1 1/2	-24	38.1	1-1/2	166	104	64
16A73-32-24	38	1 1/2	-24	38.1	2	129	66	79
16A73-32-32	51	2	-32	50.8	2	194	122	79

Find SAE flanges in section F.

Fittings with standard O-ring seals can be used for temperatures from -40 °C up to +105 °C.

Find O-rings in section F. Special O-rings are available on request.

Approved **fitting series** for hose types:

73 CM4SHP | 731TC

6F ISO 6162-2 Flange 45° Elbow – Heavy Series

ISO 12151-3 – E45-S – SFS 45°

(42.0 MPa/ 6000 psi)

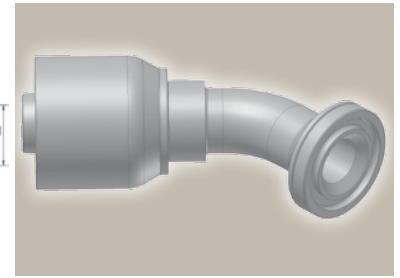
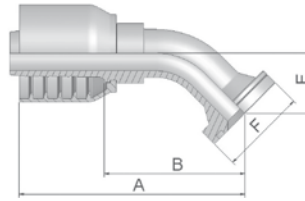

Part Number	Hose I.D.				Flange Inch	A mm	B mm	E mm	F mm
	DN	Inch	Size	mm					
16F73-12-12	19	3/4	-12	19.1	3/4	110	62	26	41
16F73-16-12	19	3/4	-12	19.1	1	110	62	26	48
16F73-12-16	25	1	-16	25.4	3/4	123	73	32	41
16F73-16-16	25	1	-16	25.4	1	129	79	32	48
16F73-20-16	25	1	-16	25.4	1-1/4	129	79	32	54
16F73-16-20	31	1 1/4	-20	31.8	1	157	93	33	48
16F73-20-20	31	1 1/4	-20	31.8	1-1/4	163	98	38	54
16F73-24-20	31	1 1/4	-20	31.8	1-1/2	163	99	38	63
16F73-24-24	38	1 1/2	-24	38.1	1-1/2	178	115	44	64
16F73-32-32	51	2	-32	50.8	2	230	158	56	79

Find SAE flanges in section F.

Fittings with standard O-ring seals can be used for temperatures from -40 °C up to +105 °C.

Find O-rings in section F. Special O-rings are available on request.

6N ISO 6162-2 Flange 90° Elbow

ISO 12151-3 – E-S – SFS 90°

(42.0 MPa/ 6000 psi)

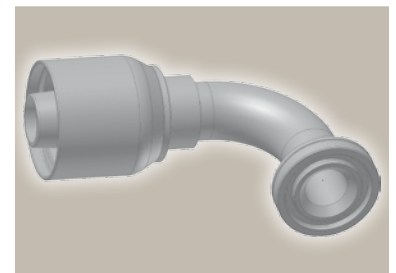
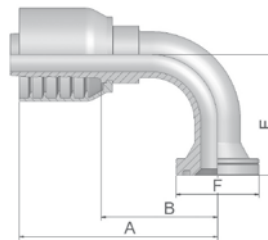

Part Number	Hose I.D.				Flange Inch	A mm	B mm	E mm	F mm
	DN	Inch	Size	mm					
16N73-12-12	19	3/4	-12	19.1	3/4	101	53	58	41
16N73-16-12	19	3/4	-12	19.1	1	111	63	58	48
16N73-20-12	19	3/4	-12	19.1	1-1/4	111	63	63	54
16N73-12-16	25	1	-16	25.4	3/4	108	57	70	41
16N73-16-16	25	1	-16	25.4	1	122	71	70	48
16N73-20-16	25	1	-16	25.4	1-1/4	122	71	70	54
16N73-16-20	31	1 1/4	-20	31.8	1	137	73	90	48
16N73-20-20	31	1 1/4	-20	31.8	1-1/4	172	108	90	54
16N73-24-20	31	1 1/4	-20	31.8	1-1/2	172	108	76	64
16N73-24-24	38	1 1/2	-24	38.1	1-1/2	166	103	104	64
16N73-32-32	51	2	-32	50.8	2	229	157	138	79

Find SAE flanges in section F.

Fittings with standard O-ring seals can be used for temperatures from -40 °C up to +105 °C.

Find O-rings in section F. Special O-rings are available on request.

Approved **fitting series** for hose types:

73 CM4SHP 731TC

XA Caterpillar® Flange
Straight

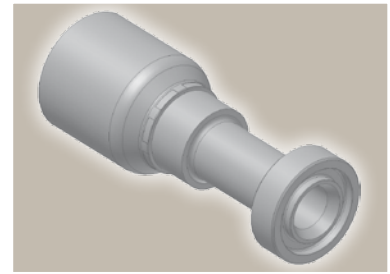
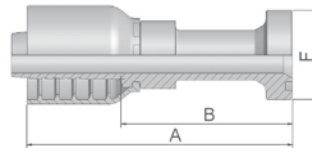

Part Number	Hose I.D.				Flange Inch	A mm	B mm	F mm
	DN	Inch	Size	mm				
1XA73-12-12	19	3/4	-12	19.1	3/4	123	75	41
1XA73-16-12	19	3/4	-12	19.1	1	134	86	48
1XA73-16-16	25	1	-16	25.4	1	138	88	48

Fittings with standard O-ring seals can be used for temperatures from -40 °C up to +105 °C.
Find O-rings in section F. Special O-rings are available on request.

XF Caterpillar® Flange
45° Elbow

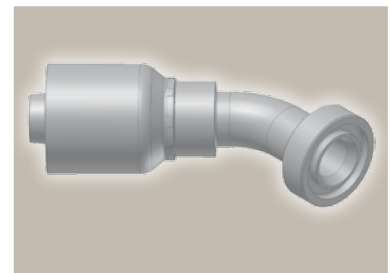
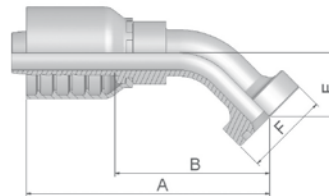

Part Number	Hose I.D.				Flange Inch	A mm	B mm	E mm	F mm
	DN	Inch	Size	mm					
1XF73-12-12	19	3/4	-12	19.1	3/4	123	75	31	41
1XF73-16-12	19	3/4	-12	19.1	1	122	74	31	48
1XF73-16-16	25	1	-16	25.4	1	139	88	36	48

Fittings with standard O-ring seals can be used for temperatures from -40 °C up to +105 °C.
Find O-rings in section F. Special O-rings are available on request.

Approved **fitting series** for hose types:

73 CM4SHP | 731TC

XG Caterpillar® Flange
60° Elbow

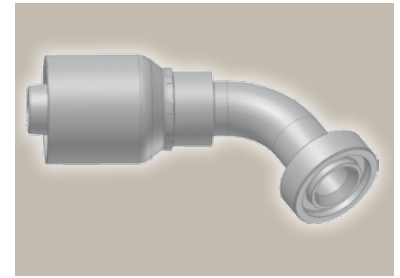
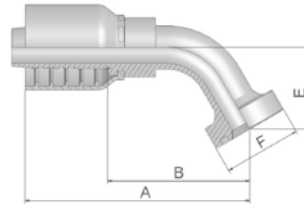

Part Number	Hose I.D.				Flange Inch	A mm	B mm	E mm	F mm
	DN	Inch	Size	mm					
1XG73-12-12	19	3/4	-12	19.1	3/4	138	90	42	41
1XG73-16-16	25	1	-16	25.4	1	160	109	50	48
1XG73-20-16	25	1	-16	25.4	1-1/4	153	103	48	54

Fittings with standard O-ring seals can be used for temperatures from -40 °C up to +105 °C.
Find O-rings in section F. Special O-rings are available on request.

XN Caterpillar® Flange
90° Elbow

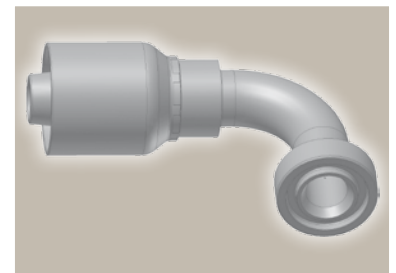
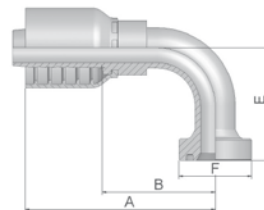

Part Number	Hose I.D.				Flange Inch	A mm	B mm	E mm	F mm
	DN	Inch	Size	mm					
1XN73-12-12	19	3/4	-12	19.1	3/4	111	63	63	41
1XN73-16-16	25	1	-16	25.4	1	128	78	74	48
1XN73-20-20	31	1 1/4	-20	31.8	1-1/4	172	108	77	54

Fittings with standard O-ring seals can be used for temperatures from -40 °C up to +105 °C.
Find O-rings in section F. Special O-rings are available on request.

Approved **fitting series** for hose types:

73 CM4SHP | 731TC

Steck0®

Page Ce-1

S0

Ce-1



Steck0® fitting
Straight

Super Steck0®

Page Ce-1

A0







Ce-1



Super Steck0® fitting



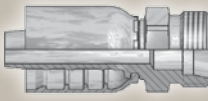

DIN – Metric

Page Ce-2 – Ce-5

<p>CA Ce-2</p>  <p>Female Metric 24° Light Series with O-Ring Swivel – Straight ISO 12151-2-SWS-L – DKOL</p>	<p>CE Ce-2</p>  <p>Female Metric 24° Light Series with O-Ring Swivel – 45° Elbow ISO 12151-2-SWE 45°-L – DKOL 45°</p>	<p>CF Ce-3</p>  <p>Female Metric 24° Light Series with O-Ring Swivel – 90° Elbow ISO 12151-2-SWE-L – DKOL 90°</p>	<p>C9 Ce-3</p>  <p>Female Metric 24° – Swivel Heavy Series with O-Ring Straight ISO 12151-2-SWS-S – DKOS</p>
<p>OC Ce-4</p>  <p>Female Metric 24° – Swivel Heavy Series with O-Ring 45° Elbow ISO 12151-2 – SWE 45°-S – DKOS 45°</p>	<p>1C Ce-4</p>  <p>Female Metric 24° – Swivel Heavy Series with O-Ring 90° Elbow ISO 12151-2-SWE-S – DKOS 90°</p>	<p>D2 Ce-5</p>  <p>Male Metric 24° – Rigid Heavy Series – Straight ISO 12151-2-S-S – CES</p>	

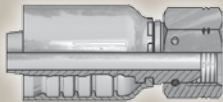

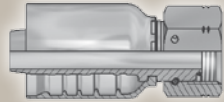
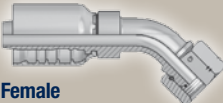
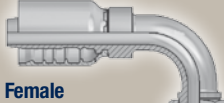

BSP

Page Ce-6 – Ce-9

<p>92 Ce-6</p>  <p>Female BSP Parallel Pipe Swivel – Straight (60° Cone) BS5200-A – DKR</p>	<p>B1 Ce-6</p>  <p>Female BSP Parallel Pipe Swivel 45° Elbow (60° Cone) BS 5200-D – DKR 45°</p>	<p>B2 Ce-7</p>  <p>Female BSP Parallel Pipe Swivel 90° Elbow (60° Cone) BS 5200-B – DKR 90°</p>	<p>EA Ce-7</p>  <p>BSP Swivel Female with O-Ring (60° Cone) BS 5200 – ISO 12151-6 – DKOR</p>
<p>EB Ce-8</p>  <p>BSP Swivel Female with O-Ring 45° Elbow (60° Cone) BS 5200 – ISO 12151-6 – DKOR 45°</p>	<p>EC Ce-8</p>  <p>BSP Swivel Female with O-Ring 90° Elbow (60° Cone) BS 5200 – ISO 12151-6 – DKOR 90°</p>	<p>D9 Ce-9</p>  <p>Male BSP Parallel Pipe Rigid – Straight (60° Cone) BS5200 – AGR</p>	

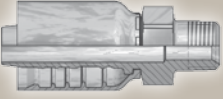
SAE

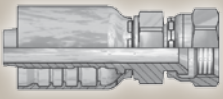
Page Ce-10 – Ce-12

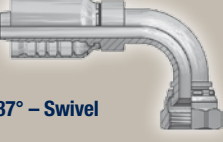
<p>01 Ce-10</p>  <p>Male NPTF Pipe Rigid – Straight SAE J476A / J516 – AGN</p>	<p>03 Ce-10</p>  <p>Male JIC 37° – Rigid Straight ISO12151-5-S – AGJ</p>	<p>06 Ce-11</p>  <p>Female JIC 37° – Swivel Straight ISO12151-5-SWS – DKJ</p>	<p>37 Ce-11</p>  <p>Female JIC 37° – Swivel 45° Elbow ISO 12151-5-SWE 45° – DKJ 45°</p>
<p>39 Ce-12</p>  <p>Female JIC 37° – Swivel 90° Elbow ISO 12151-5-SWES – DKJ 90°</p>			

Flange

Page Ce-13 – Ce-22

<p>15/4A Ce-13</p>  <p>ISO 6162-1 Flange Straight ISO 12151-3-S-L – SFL (35.0 MPa/ 5000 psi)</p>	<p>17/4F Ce-14</p>  <p>ISO 6162-1 Flange 45° Elbow ISO 12151-3 – E45S – L – SFL 45° (35.0 MPa/ 5000 psi)</p>	<p>19/4N Ce-15</p>  <p>ISO 6162-1 Flange 90° Elbow ISO 12151-3-E-L – SFL 90° (35.0 MPa/ 5000 psi)</p>	<p>6A Ce-16</p>  <p>ISO 6162-2 Flange Straight ISO 12151-3-S-S – SFS (42.0 MPa/ 6000 psi)</p>
<p>6E Ce-17</p>  <p>ISO 6162-2 Flange 30° Elbow SFS 30° (42.0 MPa/ 6000 psi)</p>	<p>6F Ce-17</p>  <p>ISO 6162-2 Flange 45° Elbow – Heavy Series ISO 12151-3 – E45-S – SFS 45° (42.0 MPa/ 6000 psi)</p>	<p>6N Ce-18</p>  <p>ISO 6162-2 Flange 90° Elbow ISO 12151-3 – E-S – SFS 90° (42.0 MPa/ 6000 psi)</p>	<p>X5 Ce-18</p>  <p>Flange – Straight Full flange system for ISO 6162-1 or ISO 6162-2</p>
<p>X7 Ce-19</p>  <p>Flange – 45° Elbow Full flange system for ISO 6162-1 or ISO 6162-2</p>	<p>X9 Ce-19</p>  <p>Flange – 90° Elbow Full flange system for ISO 6162-1 or ISO 6162-2</p>	<p>XA Ce-20</p>  <p>Caterpillar® Flange Straight</p>	<p>XF Ce-20</p>  <p>Caterpillar® Flange 45° Elbow</p>
<p>XN Ce-21</p>  <p>Caterpillar® Flange 90° Elbow</p>	<p>K5 Ce-21</p>  <p>Komatsu® Flange Straight</p>	<p>K7 Ce-22</p>  <p>Komatsu® Flange 45° Elbow</p>	<p>K9 Ce-22</p>  <p>Komatsu® Flange 90° Elbow</p>

ORFS

Page Ce-23 – Ce-24

<p>JC Ce-23</p>  <p>Female ORFS Swivel – Straight Short ISO 12151-1 – SWSA SAE J516 – ORFS</p>	<p>J7 Ce-23</p>  <p>Female ORFS – Swivel 45° Elbow ISO 12151-1 – SWE 45° SAE J516 – ORFS 45°</p>	<p>J9 Ce-24</p>  <p>Female ORFS – Swivel 90° Elbow – Short Drop ISO 12151-1 – SWES SAE J516 – ORFS 90°</p>	<p>JM Ce-24</p>  <p>ORFS Male ISO 12151-1-S – SAE J516</p>
--	--	---	--

S0 **SteckO® fitting**
Straight

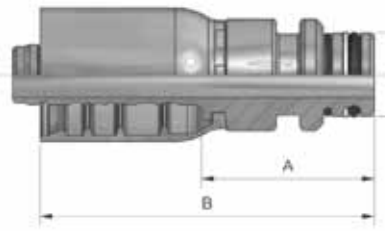

Part Number	Hose I.D.				A mm	B mm	F mm
	DN	Inch	Size	mm			
1SO77-8-8	12	1/2	-8	12.7	72	37	18
1SO77-12-12	19	3/4	-12	19.1	94	41	24

A0 **Super SteckO® fitting**

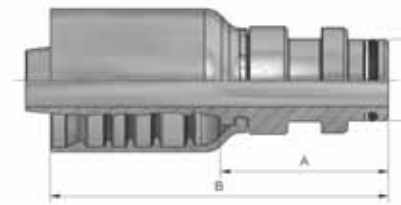

Part Number	Hose I.D.				A mm	B mm	F mm
	DN	Inch	Size	mm			
1A077-8-8	12	1/2	-8	12.7	84	49	16
1A077-12-12	19	3/4	-12	19.1	91	45	22
1A077-16-16	25	1	-16	25.4	119	65	31
1A077-20-20	31	1 1/4	-20	31.8	134	70	38
1A077-24-24	38	1 1/2	-24	38.1	151	75	44
1A077-32-32	51	2	-32	50.8	168	80	50

Approved **fitting series** for hose types:

77 787TC 797TC

CA Female Metric 24° Light Series with O-Ring Swivel – Straight

ISO 12151-2-SWS-L – DKOL

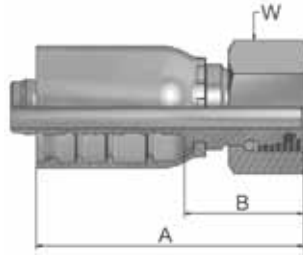

Part Number	Hose I.D.				Thread metric	Tube O.D. mm	A mm	B mm	W mm
	DN	Inch	Size	mm					
1CA77-15-8	12	1/2	-8	12.7	M22x1,5	15	63	28	27
1CA77-22-12	19	3/4	-12	19.1	M30x2	22	73	27	36
1CA77-22-16	25	1	-16	25.4	M30x2	22	88	33	36
1CA77-28-16	25	1	-16	25.4	M36x2	28	89	35	41
1CA77-35-20	31	1 1/4	-20	31.8	M45x2	35	100	37	50
1CA77-42-24	38	1 1/2	-24	38.1	M52x2	42	106	39	60

CE Female Metric 24° Light Series with O-Ring Swivel – 45° Elbow

ISO 12151-2-SWE 45°-L – DKOL 45°

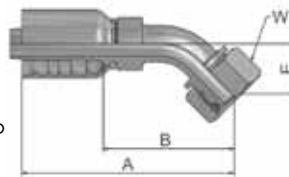

Part Number	Hose I.D.				Thread metric	Tube O.D. mm	A mm	B mm	E mm	W mm
	DN	Inch	Size	mm						
1CE77-22-12	19	3/4	-12	19.1	M30x2	22	120	74	29	36
1CE77-28-16	25	1	-16	25.4	M36x2	28	142	88	33	41
1CE77-35-20	31	1 1/4	-20	31.8	M45x2	35	162	98	37	50

Approved **fitting series** for hose types:

77 787TC 797TC

CF **Female Metric 24°
Light Series with O-Ring
Swivel – 90° Elbow**

ISO 12151-2-SWE-L – DKOL 90°

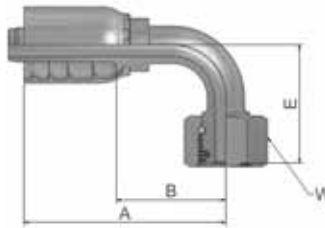

Part Number	Hose I.D.				Thread metric	Tube O.D. mm	A mm	B mm	E mm	W mm
	DN	Inch	Size	mm						
1CF77-15-8	12	1/2	-8	12.7	M22x1,5	15	76	41	44	27
1CF77-22-12	19	3/4	-12	19.1	M30x2	22	108	62	59	36
1CF77-42-24	38	1 1/2	-24	38.1	M52x2	42	175	108	101	60

C9 **Female Metric 24° – Swivel
Heavy Series with O-Ring
Straight**

ISO 12151-2-SWS-S – DKOS

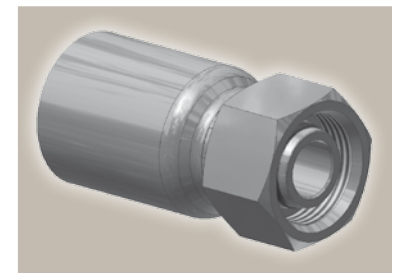
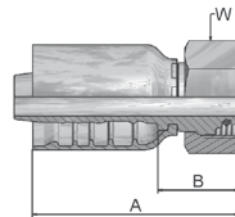

Part Number	Hose I.D.				Thread metric	A mm	B mm	W mm
	DN	Inch	Size	mm				
1C977-16-8	12	1/2	-8	12.7	M24x1,5	60	25	30
1C977-16-10	16	5/8	-10	15.9	M24x1,5	67	28	30
1C977-20-10	16	5/8	-10	15.9	M30x2	67	28	36
1C977-20-12	19	3/4	-12	19.1	M30x2	76	30	36
1C977-25-12	19	3/4	-12	19.1	M36x2	77	31	46
1C977-30-16	25	1	-16	25.4	M42x2	89	35	50
1C977-30-20	31	1 1/4	-20	31.8	M42x2	102	39	50
1C977-38-20	31	1 1/4	-20	31.8	M52x2	100	36	60
1C977-38-24	38	1 1/2	-24	38.1	M52x2	109	42	60

Fittings with standard O-ring seals can be used for temperatures from -40 °C up to +105 °C.
Find O-rings in section F. Special O-rings are available on request.

Approved **fitting series** for hose types:

77 787TC 797TC

0C Female Metric 24° – Swivel Heavy Series with O-Ring 45° Elbow

ISO 12151-2 – SWE 45°-S – DKOS 45°

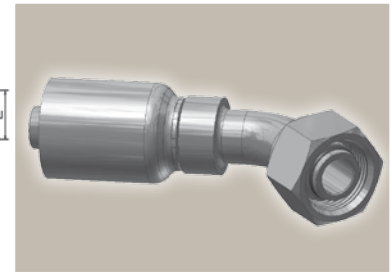
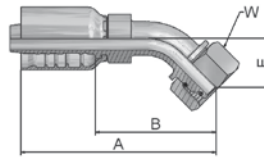

Part Number	Hose I.D.				Thread metric	A mm	B mm	E mm	W mm
	DN	Inch	Size	mm					
10C77-16-8	12	1/2	-8	12.7	M24x1.5	83	49	24	30
10C77-20-10	16	5/8	-10	15.9	M30x2	107	68	28	36
10C77-20-12	19	3/4	-12	19.1	M30x2	120	74	30	36
10C77-25-12	19	3/4	-12	19.1	M36x2	119	73	29	46
10C77-30-16	25	1	-16	25.4	M42x2	142	88	33	50
10C77-38-20	31	1 1/4	-20	31.8	M52x2	161	97	37	60
10C77-38-24	38	1 1/2	-24	38.1	M52x2	205	128	49	60

Fittings with standard O-ring seals can be used for temperatures from -40 °C up to +105 °C.
Find O-rings in section F. Special O-rings are available on request.

1C Female Metric 24° – Swivel Heavy Series with O-Ring 90° Elbow

ISO 12151-2-SWE-S – DKOS 90°

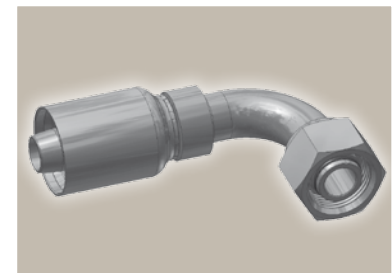
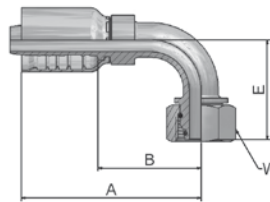

Part Number	Hose I.D.				Thread metric	A mm	B mm	E mm	W mm
	DN	Inch	Size	mm					
11C77-16-8	12	1/2	-8	12.7	M24x1.5	77	42	45	30
11C77-20-10	16	5/8	-10	15.9	M30x2	92	53	53	36
11C77-20-12	19	3/4	-12	19.1	M30x2	108	62	60	36
11C77-25-12	19	3/4	-12	19.1	M36x2	108	62	59	46
11C77-30-16	25	1	-16	25.4	M42x2	131	77	69	50
11C77-38-20	31	1 1/4	-20	31.8	M52x2	151	87	78	60
11C77-38-24	38	1 1/2	-24	38.1	M52x2	179	112	101	60

Fittings with standard O-ring seals can be used for temperatures from -40 °C up to +105 °C.
Find O-rings in section F. Special O-rings are available on request.

Approved **fitting series** for hose types:

77 787TC | 797TC

D2 Male Metric 24° – Rigid Heavy Series – Straight

ISO 12151-2-S-S – CES

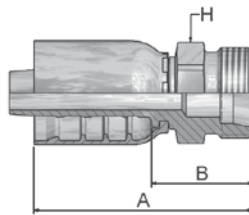

Part Number	Hose I.D.				Thread metric	A mm	B mm	H mm
	DN	Inch	Size	mm				
1D277-16-8	12	1/2	-8	12.7	M24x1.5	64	30	24
1D277-20-10	16	5/8	-10	15.9	M30x2	72	34	30
1D277-20-12	19	3/4	-12	19.1	M30x2	84	38	30
1D277-25-12	19	3/4	-12	19.1	M36x2	86	40	36
1D277-30-16	25	1	-16	25.4	M42x2	99	45	46
1D277-38-20	31	1 1/4	-20	31.8	M52x2	114	51	55
1D277-38-24	38	1 1/2	-24	38.1	M52x2	120	53	55

Approved **fitting series** for hose types:

77 787TC 797TC

92 Female BSP Parallel Pipe Swivel – Straight (60° Cone)

BS5200-A – DKR

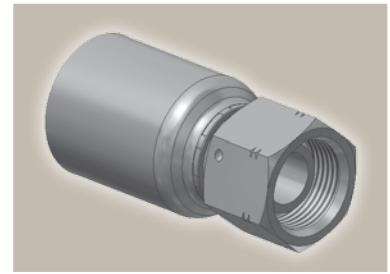
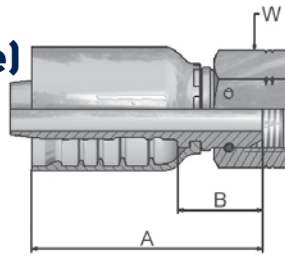

Part Number	Hose I.D.				Thread BSP	A mm	B mm	W mm
	DN	Inch	Size	mm				
19277-8-8	12	1/2	-8	12.7	1/2x14	57	23	27
19277-12-12	19	3/4	-12	19.1	3/4x14	73	27	32
19277-12-16	25	1	-16	25.4	3/4x14	83	29	32
19277-16-16	25	1	-16	25.4	1x11	91	37	41

B1 Female BSP Parallel Pipe Swivel 45° Elbow (60° Cone)

BS 5200-D – DKR 45°

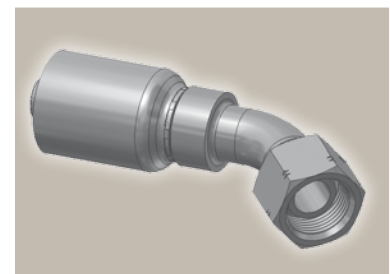
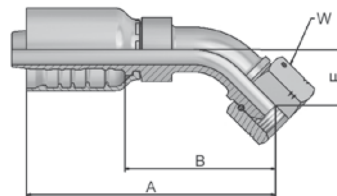

Part Number	Hose I.D.				Thread BSP	A mm	B mm	E mm	W mm
	DN	Inch	Size	mm					
1B177-8-8	12	1/2	-8	12.7	1/2x14	84	49	20	27
1B177-12-12	19	3/4	-12	19.1	3/4x14	116	70	26	32
1B177-16-12	19	3/4	-12	19.1	1x11	124	78	34	41
1B177-16-16	25	1	-16	25.4	1x11	145	91	36	41

Approved **fitting series** for hose types:

77 787TC | 797TC

B2 Female BSP Parallel Pipe Swivel 90° Elbow (60° Cone)

BS 5200-B – DKR 90°

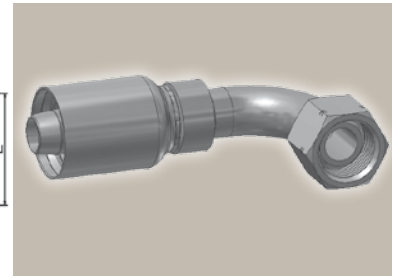
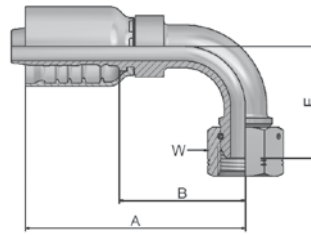

Part Number	Hose I.D.				Thread BSP	A mm	B mm	E mm	W mm
	DN	Inch	Size	mm					
1B277-8-8	12	1/2	-8	12.7	1/2x14	76	41	40	27
1B277-12-12	19	3/4	-12	19.1	3/4x14	108	62	55	32
1B277-16-16	25	1	-16	25.4	1x11	131	77	74	41

EA BSP Swivel Female with O-Ring (60° Cone)

BS 5200 – ISO 12151-6 – DKOR

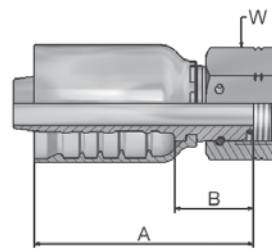

Part Number	Hose I.D.				Thread BSP	A mm	B mm	W mm
	DN	Inch	Size	mm				
1EA77-8-8	12	1/2	-8	12.7	1/2x14	58	23	27
1EA77-10-10	16	5/8	-10	15.9	5/8x14	62	23	30
1EA77-12-10	16	5/8	-10	15.9	3/4x14	63	24	32
1EA77-12-12	20	3/4	-12	19.1	3/4x14	72	26	32
1EA77-16-12	20	3/4	-12	19.1	1x11	82	36	41
1EA77-12-16	25	1	-16	25.4	3/4x14	83	29	32
1EA77-16-16	25	1	-16	25.4	1x11	90	36	41
1EA77-20-20	31	1 1/4	-20	31.8	1-1/4x11	96	33	50
1EA77-24-24	38	1 1/2	-24	38.1	1-1/2	103	36	55
1EA77-32-32	51	2	-32	50.8	2	118	40	70

Approved **fitting series** for hose types:

77 787TC 797TC

EB **BSP Swivel Female
with O-Ring
45° Elbow (60° Cone)**

BS 5200 – ISO 12151-6 – DKOR 45°

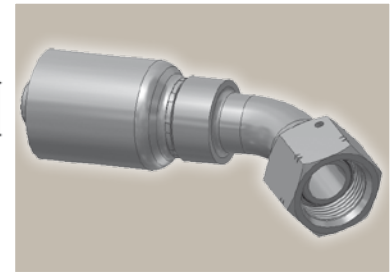
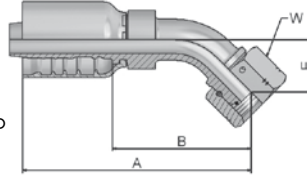

Part Number	Hose I.D.				Thread BSP	A mm	B mm	E mm	W mm
	DN	Inch	Size	mm					
1EB77-8-8	12	1/2	-8	12.7	1/2x14	80	45	20	27
1EB77-10-10	16	5/8	-10	15.9	5/8x14	101	62	22	30
1EB77-12-10	16	5/8	-10	15.9	3/4x14	103	64	24	32
1EB77-12-12	20	3/4	-12	19.1	3/4x14	117	71	27	32
1EB77-16-12	20	3/4	-12	19.1	1x11	120	74	29	41
1EB77-16-16	25	1	-16	25.4	1x11	144	90	35	41
1EB77-20-20	31	1 1/4	-20	31.8	1-1/4x11	159	95	35	50
1EB77-24-24	38	1 1/2	-24	38.1	1-1/2	196	129	50	55
1EB77-32-32	51	2	-32	50.8	2	255	178	86	70

EC **BSP Swivel Female
with O-Ring
90° Elbow (60° Cone)**

BS 5200 – ISO 12151-6 – DKOR 90°

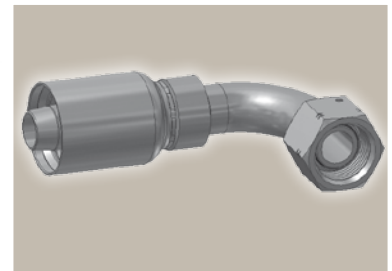
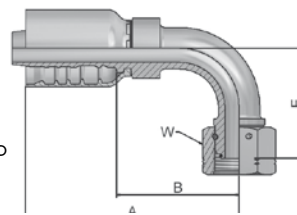

Part Number	Hose I.D.				Thread BSP	A mm	B mm	E mm	W mm
	DN	Inch	Size	mm					
1EC77-8-8	12	1/2	-8	12.7	1/2x14	76	41	40	27
1EC77-10-10	16	5/8	-10	15.9	5/8x14	92	53	44	30
1EC77-12-10	16	5/8	-10	15.9	3/4x14	92	53	47	32
1EC77-12-12	19	3/4	-12	19.1	3/4x14	108	62	55	32
1EC77-16-16	25	1	-16	25.4	1x11	131	77	72	41
1EC77-20-20	31	1 1/4	-20	31.8	1-1/4x11	151	87	75	50
1EC77-24-24	38	1 1/2	-24	38.1	1-1/2	196	129	50	55
1EC77-32-32	51	2	-32	50.8	2	255	178	86	70
1EC77-32-32	51	2	-32	50.8	2	255	178	86	70

Approved **fitting series** for hose types:

77 787TC | 797TC

D9 **Male BSP Parallel Pipe
Rigid – Straight (60° Cone)**

BS5200 – AGR

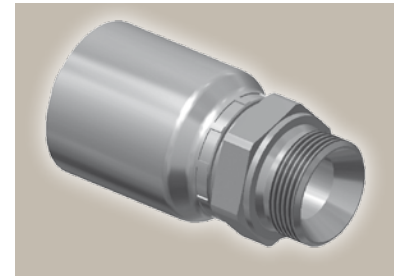
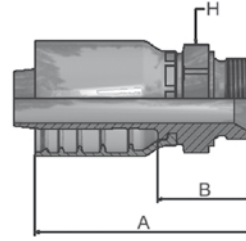

Part Number	Hose I.D.				Thread BSP	A mm	B mm	H mm
	DN	Inch	Size	mm				
1D977-8-8	12	1/2	-8	12.7	1/2x14	68	33	27
1D977-10-10	16	5/8	-10	15.9	5/8x14	74	36	30
1D977-12-12	19	3/4	-12	19.1	3/4x14	87	41	32
1D977-16-12	19	3/4	-12	19.1	1x11	91	45	41
1D977-16-16	25	1	-16	25.4	1x11	101	47	41
1D977-20-16	25	1	-16	25.4	1-1/4x11	103	49	50
1D977-20-20	31	1 1/4	-20	31.8	1-1/4x11	113	50	50
1D977-24-24	38	1 1/2	-24	38.1	1-1/2x11	124	57	55

Approved **fitting series** for hose types:

77 787TC 797TC

01 Male NPTF Pipe Rigid – Straight

SAE J476A / J516 – AGN

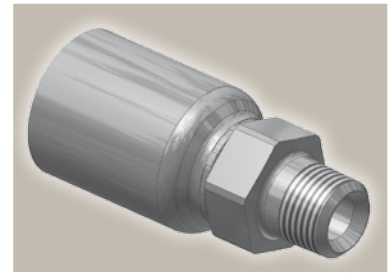
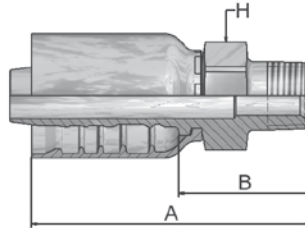

Part Number	Hose I.D.				Thread NPTF	A mm	B mm	H mm
	DN	Inch	Size	mm				
10177-8-8	12	1/2	-8	12.7	1/2x14	69	35	22
10177-8-12	19	3/4	-12	19.1	1/2x14	87	41	30
10177-12-12	19	3/4	-12	19.1	3/4x14	87	41	30
10177-16-16	25	1	-16	25.4	1x11-1/2	103	49	36
10177-20-20	31	1 1/4	-20	31.8	1-1/4x11	116	53	46
10177-24-24	38	1 1/2	-24	38.1	1-1/2x11-1/2	124	57	50
10177-32-32	51	2	-32	50.8	2-11-1/2	143	66	65

03 Male JIC 37° – Rigid Straight

ISO12151-5-S – AGJ

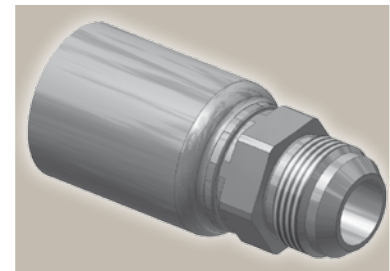
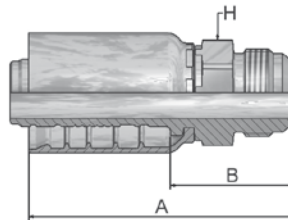

Part Number	Hose I.D.				Thread UNF	A mm	B mm	H mm
	DN	Inch	Size	mm				
10377-8-8	12	1/2	-8	12.7	3/4x16	66	32	22
10377-10-8	12	1/2	-8	12.7	7/8x14	69	34	24
10377-10-10	16	5/8	-10	15.9	7/8-14	76	38	24
10377-12-10	16	5/8	-10	15.9	1-1/16x12	82	43	30
10377-12-12	19	3/4	-12	19.1	1-1/16x12	89	43	30
10377-16-12	19	3/4	-12	19.1	1-5/16x12	92	46	36
10377-16-16	25	1	-16	25.4	1-5/16x12	101	47	36
10377-20-16	25	1	-16	25.4	1-5/8x12	110	56	50
10377-20-20	31	1 1/4	-20	31.8	1-5/8x12	118	55	50
10377-32-32	51	2	-32	50.8	2-1/2x12	148	71	65

Approved **fitting series** for hose types:

77 787TC 797TC

06 Female JIC 37° – Swivel Straight

ISO12151-5-SWS – DKJ

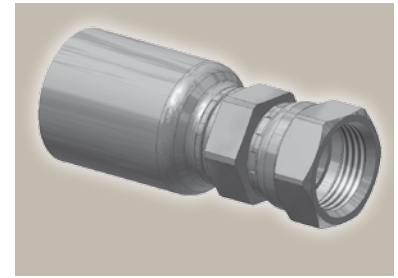
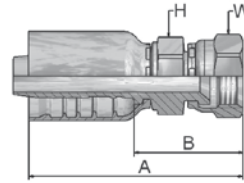

Part Number	Hose I.D.				Thread UNF	A mm	B mm	H mm	W mm
	DN	Inch	Size	mm					
10677-8-8	12	1/2	-8	12.7	3/4x16	71	37	22	22
10677-10-8	12	1/2	-8	12.7	7/8x14	74	39	22	27
10677-12-8	12	1/2	-8	12.7	1-1/16x12	80	46	30	32
10677-10-10	16	5/8	-10	15.9	7/8x14	81	42	24	27
10677-12-10	16	5/8	-10	15.9	1-1/16x12	84	45	30	32
10677-10-12	19	3/4	-12	19.1	7/8x14	92	46	30	27
10677-12-12	19	3/4	-12	19.1	1-1/16x12	94	48	30	32
10677-14-12	19	3/4	-12	19.1	1-5/16x12	99	53	36	41
10677-16-12	19	3/4	-12	19.1	1-5/16x12	99	53	36	41
10677-12-16	25	1	-16	25.4	1-1/16x12	102	48	36	32
10677-16-16	25	1	-16	25.4	1-5/16x12	106	52	36	41
10677-20-16	25	1	-16	25.4	1-5/8x12	109	55	41	50
10677-20-20	31	1 1/4	-20	31.8	1-5/8-12	124	60	46	50
10677-24-20	31	1 1/4	-20	31.8	1-7/8x12	108	44	50	60
10677-24-24	38	1 1/2	-24	38.1	1-7/8x12	117	50	50	60
10677-32-32	51	2	-32	50.8	2-1/2x12	136	59	65	75

37 Female JIC 37° – Swivel 45° Elbow

ISO 12151-5-SWE 45° – DKJ 45°

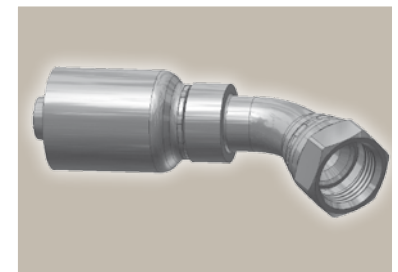
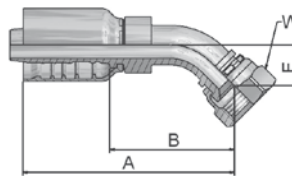

Part Number	Hose I.D.				Thread UNF	A mm	B mm	E mm	W mm
	DN	Inch	Size	mm					
13777-8-8	12	1/2	-8	12.7	3/4x16	73	38	15	22
13777-10-8	12	1/2	-8	12.7	7/4x14	76	41	16	27
13777-10-10	16	5/8	-10	15.9	7/4x14	93	54	16	27
13777-12-10	16	5/8	-10	15.9	1-1/16x12	100	61	21	32
13777-12-12	19	3/4	-12	19.1	1-1/16x12	111	65	21	32
13777-16-12	25	1	-16	25.4	1-5/16x12	108	62	56	41
13777-16-16	25	1	-16	25.4	1-5/16x12	133	79	24	41
13777-20-20	31	1 1/4	-20	31.8	1-5/8x12	153	90	32	50
13777-24-24	38	1 1/2	-24	38.1	1-7/8x12	201	134	58	60
13777-32-32	51	2	-32	50.8	2-1/2x12	258	181	72	75



Approved **fitting series** for hose types:

77 787TC 797TC

39 Female JIC 37° – Swivel 90° Elbow

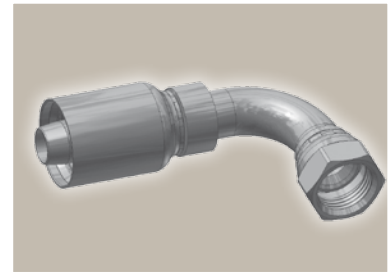
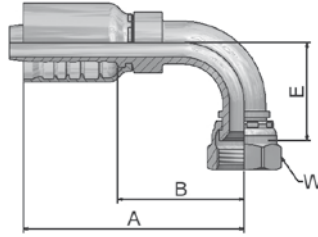
ISO 12151-5-SWES – DKJ 90°



Part Number	 Hose I.D.				 Thread	A mm	B mm	E mm	 W
	DN	Inch	Size	mm	UNF				mm
13977-8-8	12	1/2	-8	12.7	3/4x16	71	36	29	22
13977-10-8	12	1/2	-8	12.7	7/4x14	76	41	32	27
13977-10-10	16	5/8	-10	15.9	7/8x14	88	50	33	27
13977-12-10	16	5/8	-10	15.9	1-1/16x12	92	53	48	32
13977-12-12	19	3/4	-12	19.1	1-1/16x12	108	62	48	32
13977-16-12	19	3/4	-12	19.1	1-5/16x12	108	62	56	41
13977-16-16	25	1	-16	25.4	1-5/16x12	131	77	74	41
13977-20-20	31	1 1/4	-20	31.8	1-5/8x12	148	84	78	50
13977-24-24	38	1 1/2	-24	38.1	1-7/8x12	175	108	102	60
13977-32-32	51	2	-32	50.8	2-1/2x12	236	159	152	75

Approved **fitting series** for hose types:

 77 787TC | 797TC

15/4A ISO 6162-1 Flange Straight

ISO 12151-3-S-L – SFL

(35.0 MPa/ 5000 psi)

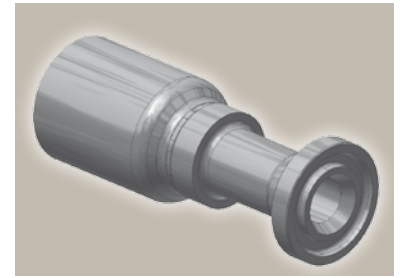
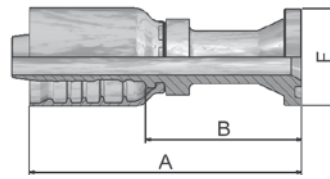

Part Number	Hose I.D.				Flange		A mm	B mm	F mm
	DN	Inch	Size	mm	Inch				
11577-8-8	12	1/2	-8	12.7	1/2	90	55	30	
11577-12-8	12	1/2	-8	12.7	3/4	67	33	38	
11577-10-10	16	5/8	-10	15.9	5/8	99	60	34	
11577-12-10	16	5/8	-10	15.9	3/4	78	36	38	
11577-12-12	19	3/4	-12	19.1	3/4	107	62	38	
11577-16-12	19	3/4	-12	19.1	1	88	42	45	
11577-16-16	25	1	-16	25.4	1	119	65	45	
14A77-20-16	25	1	-16	25.4	1-1/4	87	33	51	
14A77-20-20	31	1 1/4	-20	31.8	1-1/4	138	74	51	
14A77-24-20	31	1 1/4	-20	31.8	1-1/2	100	37	60	
14A77-24-24	38	1 1/2	-24	38.1	1-1/2	140	73	60	
14A77-32-24	38	1 1/2	-24	38.1	2	117	50	71	
14A77-32-32	51	2	-32	50.8	2	163	86	71	

Find SAE flange halves in section Eb.

Fittings with standard O-ring seals can be used for temperatures from -40 °C up to +105 °C.

Find O-rings in section F. Special O-rings are available on request.



Approved **fitting series** for hose types:

77 787TC 797TC

17/4F ISO 6162-1 Flange 45° Elbow

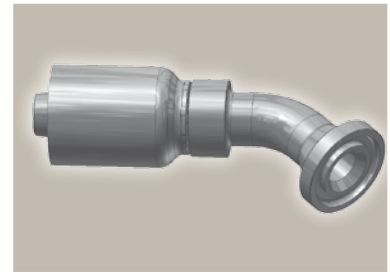
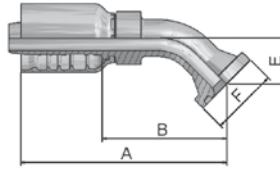
ISO 12151-3 – E45S – L – SFL 45°
(35.0 MPa/ 5000 psi)



Part Number	 Hose I.D.				 Flange	A	B	E	F
	DN	Inch	Size	mm	Inch	mm	mm	mm	mm
11777-8-8	12	1/2	-8	12.7	1/2	79	45	20	30
11777-12-8	12	1/2	-8	12.7	3/4	81	47	22	38
11777-12-12	19	3/4	-12	19.1	3/4	116	70	26	38
11777-16-12	19	3/4	-12	19.1	1	116	70	26	45
11777-16-16	25	1	-16	25.4	1	141	87	32	45
14F77-20-16	25	1	-16	25.4	1-1/4	141	87	32	51
14F77-20-20	31	1 1/4	-20	31.8	1-1/4	162	99	38	51
14F77-24-20	31	1 1/4	-20	31.8	1-1/2	162	99	38	60
14F77-24-24	38	1 1/2	-24	38.1	1-1/2	182	115	44	60
14F77-32-24	38	1 1/2	-24	38.1	2	182	115	44	71
14F77-32-32	51	2	-32	50.8	2	211	134	56	71

Find SAE flange halves in section Eb.

Fittings with standard O-ring seals can be used for temperatures from -40 °C up to +105 °C.

Find O-rings in section F. Special O-rings are available on request.

Approved **fitting series** for hose types:

77 787TC | 797TC

19/4N ISO 6162-1 Flange 90° Elbow

ISO 12151-3-E-L – SFL 90°

(35.0 MPa/ 5000 psi)

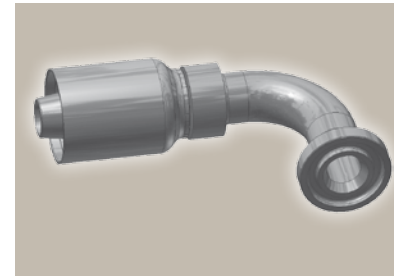
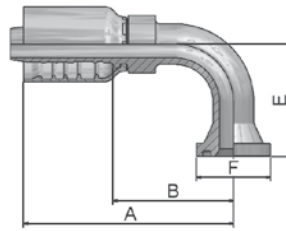

Part Number	Hose I.D.				Flange Inch	A mm	B mm	E mm	F mm
	DN	Inch	Size	mm					
11977-8-8	12	1/2	-8	12.7	1/2	76	41	41	30
11977-12-8	12	1/2	-8	12.7	3/4	80	45	42	38
11977-12-12	19	3/4	-12	19.1	3/4	108	62	58	38
11977-16-12	19	3/4	-12	19.1	1	108	62	58	45
11977-16-16	25	1	-16	25.4	1	131	77	70	45
14N77-20-16	25	1	-16	25.4	1-1/4	131	77	69	51
14N77-20-20	31	1 1/4	-20	31.8	1-1/4	151	87	90	51
14N77-24-20	31	1 1/4	-20	31.8	1-1/2	151	87	90	60
14N77-24-24	38	1 1/2	-24	38.1	1-1/2	170	103	104	60
14N77-32-24	38	1 1/2	-24	38.1	2	170	103	104	71
14N77-32-32	51	2	-32	50.8	2	206	129	138	71

Find SAE flange halves in section Eb.

Fittings with standard O-ring seals can be used for temperatures from -40 °C up to +105 °C.

Find O-rings in section F. Special O-rings are available on request.

Approved **fitting series** for hose types:



77 787TC 797TC

6A ISO 6162-2 Flange Straight

ISO 12151-3-S-S – SFS

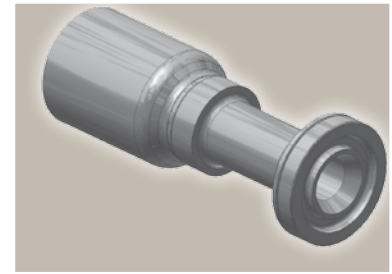
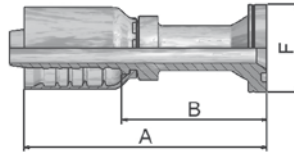
(42.0 MPa/ 6000 psi)



Part Number	 Hose I.D.				 Flange	A mm	B mm	F mm
	DN	Inch	Size	mm	Inch			
16A77-8-8	12	1/2	-8	12.7	1/2	90	55	32
16A77-12-8	12	1/2	-8	12.7	3/4	69	35	41
16A77-12-10	16	5/8	-10	15.9	3/4	75	36	41
16A77-12-12	19	3/4	-12	19.1	3/4	114	68	41
16A77-16-12	19	3/4	-12	19.1	1	88	42	48
16A77-16-16	25	1	-16	25.4	1	113	59	48
16A77-20-16	25	1	-16	25.4	1-1/4	103	49	54
16A77-16-20	31	1 1/4	-20	31.8	1	145	82	48
16A77-20-20	31	1 1/4	-20	31.8	1-1/4	146	82	54
16A77-24-20	31	1 1/4	-20	31.8	1-1/2	118	55	64
16A77-24-24	38	1 1/2	-24	38.1	1-1/2	162	96	64
16A77-32-24	38	1 1/2	-24	38.1	2	133	66	79
16A77-32-32	51	2	-32	50.8	2	182	105	79

Find SAE flange halves in section Eb.

Fittings with standard O-ring seals can be used for temperatures from -40 °C up to +105 °C.

Find O-rings in section F. Special O-rings are available on request.

Approved **fitting series** for hose types:

 787TC | 797TC

6E ISO 6162-2 Flange 30° Elbow

SFS 30°

(42.0 MPa/ 6000 psi)

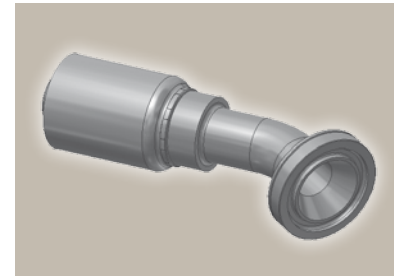
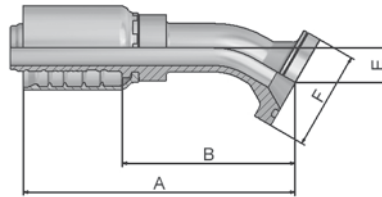

Part Number	Hose I.D.				Flange Inch	A mm	B mm	E mm	F mm
	DN	Inch	Size	mm					
16E77-12-12	19	3/4	-12	19.1	3/4	121	75	16	41
16E77-16-16	25	1	-16	25.4	1	136	82	19	48
16E77-20-16	25	1	-16	25.4	1-1/4	149	95	19	54
16E77-20-20	31	1 1/4	-20	31.8	1-1/4	167	104	22	54
16E77-24-24	38	1 1/2	-24	38.1	1-1/2	190	123	30	64
16E77-32-32	51	2	-32	50.8	2	223	145	32	79

Find SAE flange halves in section Eb.

Fittings with standard O-ring seals can be used for temperatures from -40 °C up to +105 °C.

Find O-rings in section F. Special O-rings are available on request.

6F ISO 6162-2 Flange 45° Elbow – Heavy Series

ISO 12151-3 – E45-S – SFS 45°

(42.0 MPa/ 6000 psi)

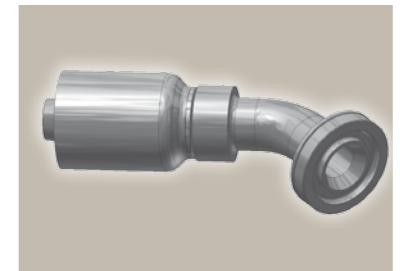
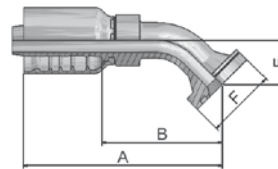

Part Number	Hose I.D.				Flange Inch	A mm	B mm	E mm	F mm
	DN	Inch	Size	mm					
16F77-8-8	12	1/2	-8	12.7	1/2	79	44	19	32
16F77-12-8	12	1/2	-8	12.7	3/4	86	51	26	41
16F77-12-10	16	5/8	-10	15.9	3/4	96	57	26	41
16F77-12-12	19	3/4	-12	19.1	3/4	116	70	26	41
16F77-16-12	19	3/4	-12	19.1	1	116	70	26	48
16F77-16-16	25	1	-16	25.4	1	141	87	32	48
16F77-20-16	25	1	-16	25.4	1-1/4	142	88	32	54
16F77-16-20	31	1 1/4	-20	31.8	1	159	95	38	48
16F77-20-20	31	1 1/4	-20	31.8	1-1/4	162	99	38	54
16F77-24-20	31	1 1/4	-20	31.8	1-1/2	162	99	38	64
16F77-24-24	38	1 1/2	-24	38.1	1-1/2	182	115	44	64
16F77-32-32	51	2	-32	50.8	2	211	134	56	79

Find SAE flange halves in section Eb.

Fittings with standard O-ring seals can be used for temperatures from -40 °C up to +105 °C.

Find O-rings in section F. Special O-rings are available on request.

Approved **fitting series** for hose types:

77 787TC | 797TC

6N ISO 6162-2 Flange 90° Elbow

ISO 12151-3 – E-S – SFS 90°
(42.0 MPa/ 6000 psi)

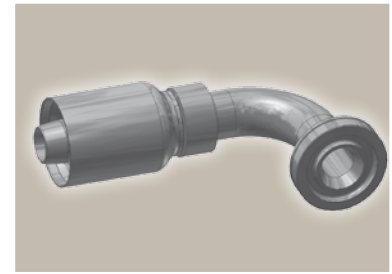
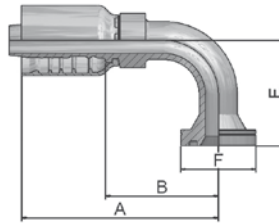

Part Number	Hose I.D.				Flange Inch	A mm	B mm	E mm	F mm
	DN	Inch	Size	mm					
16N77-8-8	12	1/2	-8	12.7	1/2	77	42	41	32
16N77-12-8	12	1/2	-8	12.7	3/4	81	47	45	41
16N77-12-10	16	5/8	-10	15.9	3/4	92	53	54	41
16N77-12-12	19	3/4	-12	19.1	3/4	108	62	58	41
16N77-16-12	19	3/4	-12	19.1	1	108	62	58	48
16N77-16-16	25	1	-16	25.4	1	131	77	70	48
16N77-20-16	25	1	-16	25.4	1-1/4	135	81	70	54
16N77-16-20	31	1 1/4	-20	31.8	1	145	82	90	48
16N77-20-20	31	1 1/4	-20	31.8	1-1/4	151	87	90	54
16N77-24-20	31	1 1/4	-20	31.8	1-1/2	151	87	90	64
16N77-24-24	38	1 1/2	-24	38.1	1-1/2	170	103	104	64
16N77-32-24	38	1 1/2	-24	38.1	2	170	103	104	79
16N77-32-32	51	2	-32	50.8	2	206	129	138	79

Find SAE flange halves in section Eb.

Fittings with standard O-ring seals can be used for temperatures from -40 °C up to +105 °C.

Find O-rings in section F. Special O-rings are available on request.

X5 Flange – Straight

Full flange system for
ISO 6162-1 or ISO 6162-2

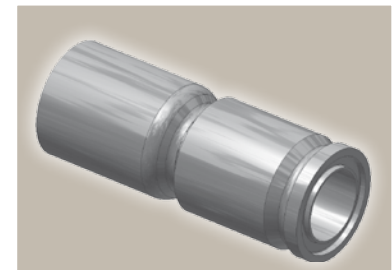
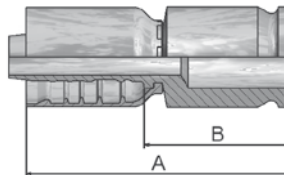

Part Number	Hose I.D.				A mm	B mm
	DN	Inch	Size	mm		
1X577-12-12	19	3/4	-12	19.1	103	57
1X577-16-12	19	3/4	-12	19.1	103	57
1X577-16-16	25	1	-16	25.4	113	59
1X577-20-16	25	1	-16	25.4	113	59
1X577-24-16	25	1	-16	25.4	113	59
1X577-20-20	31	1 1/4	-20	31.8	120	57
1X577-24-20	31	1 1/4	-20	31.8	125	60
1X577-24-24	38	1 1/2	-24	38.1	129	62

Find SAE flange halves in section Eb.

Fittings with standard O-ring seals can be used for temperatures from -40 °C up to +105 °C.

Find O-rings in section F. Special O-rings are available on request.

Approved **fitting series** for hose types:

77 787TC | 797TC

X7 Flange – 45° Elbow

Full flange system for
ISO 6162-1 or ISO 6162-2

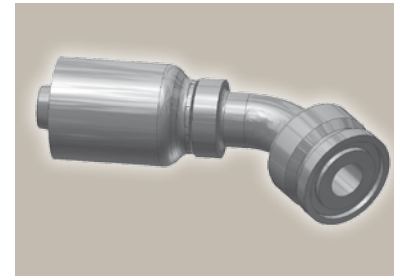
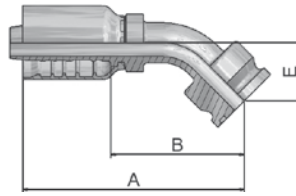



Part Number	 Hose I.D.				A mm	B mm	E mm
	DN	Inch	Size	mm			
1X777-12-12	19	3/4	-12	19.1	118	73	29
1X777-16-12	19	3/4	-12	19.1	118	72	29
1X777-16-16	25	1	-16	25.4	141	87	32
1X777-20-16	25	1	-16	25.4	147	93	38
1X777-16-20	31	1 1/4	-20	31.8	146	82	38
1X777-20-20	31	1 1/4	-20	31.8	159	96	38
1X777-24-20	31	1 1/4	-20	31.8	165	102	44
1X777-24-24	38	1 1/2	-24	38.1	183	116	45

Find full flange system on page Eb-2.

X9 Flange – 90° Elbow

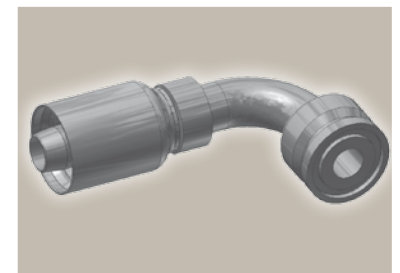
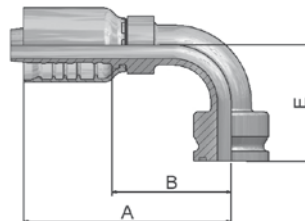
Full flange system for
ISO 6162-1 or ISO 6162-2



Part Number	 Hose I.D.				A mm	B mm	E mm
	DN	Inch	Size	mm			
1X977-8-8	12	1/2	-8	12.7	81	45	43
1X977-12-12	19	3/4	-12	19.1	108	62	61
1X977-16-12	19	3/4	-12	19.1	108	62	61
1X977-12-16	25	1	-16	25.4	110	56	70
1X977-16-16	25	1	-16	25.4	131	77	70
1X977-20-16	25	1	-16	25.4	131	77	70
1X977-16-20	31	1 1/4	-20	31.8	130	67	90
1X977-20-20	31	1 1/4	-20	31.8	148	84	90
1X977-24-20	31	1 1/4	-20	31.8	148	84	90
1X977-24-24	38	1 1/2	-24	38.1	170	103	104

Find full flange system on page Eb-2.

Approved **fitting series** for hose types:

77 787TC 797TC

XA Caterpillar® Flange
Straight

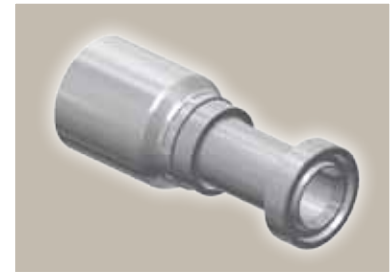
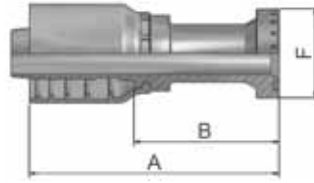

Part Number	Hose I.D.				Flange Inch	A mm	B mm	F mm
	DN	Inch	Size	mm				
1XA77-12-12	19	3/4	-12	19.1	3/4	114	68	41
1XA77-16-12	19	3/4	-12	19.1	3/4	88	42	48
1XA77-16-16	25	1	-16	25.4	1	141	87	48
1XA77-20-16	25	1	-16	25.4	1	104	50	54
1XA77-20-20	31	1 1/4	-20	31.8	1-1/4	152	88	54
1XA77-24-20	31	1 1/4	-20	31.8	1-1/2	121	57	64
1XA77-24-24	38	1 1/2	-24	38.1	1-1/2	176	109	64
1XA77-32-24	38	1 1/2	-24	38.1	2	133	66	79
1XA77-32-32	51	2	-32	50.8	2	192	115	79

XF Caterpillar® Flange
45° Elbow

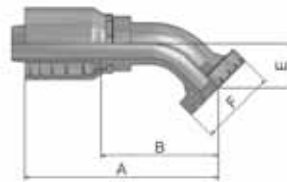

Part Number	Hose I.D.				Flange Inch	A mm	B mm	E mm	F mm
	DN	Inch	Size	mm					
1XF77-12-12	19	3/4	-12	19.1	3/4	122	76	31	41
1XF77-16-12	19	3/4	-12	19.1	1	121	75	31	48
1XF77-16-16	25	1	-16	25.4	1	145	91	36	48
1XF77-20-16	25	1	-16	25.4	1-1/4	134	80	36	54
1XF77-20-20	31	1 1/4	-20	31.8	1-1/4	161	98	37	54
1XF77-24-20	31	1 1/4	-20	31.8	1-1/2	161	98	37	64
1XF77-24-24	38	1 1/2	-24	38.1	1-1/2	183	116	45	64

Approved **fitting series** for hose types:

77 787TC | 797TC

XN Caterpillar® Flange
90° Elbow

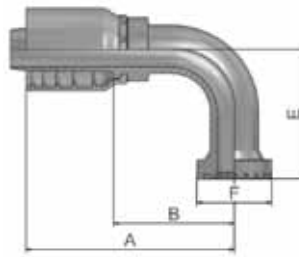

Part Number	Hose I.D.				Flange Inch	A mm	B mm	E mm	F mm
	DN	Inch	Size	mm					
1XN77-12-12	19	3/4	-12	19.1	3/4	108	62	63	41
1XN77-16-12	19	3/4	-12	19.1	1	108	62	63	48
1XN77-16-16	25	1	-16	25.4	1	131	77	74	48
1XN77-20-16	25	1	-16	25.4	1-1/4	120	66	74	54
1XN77-20-20	31	1 1/4	-20	31.8	1-1/4	151	87	94	54
1XN77-24-20	31	1 1/4	-20	31.8	1-1/2	151	87	77	64
1XN77-24-24	38	1 1/2	-24	38.1	1-1/2	160	103	106	79
1XN77-32-24	38	1 1/2	-24	38.1	2	169	103	106	79

K5 Komatsu® Flange
Straight

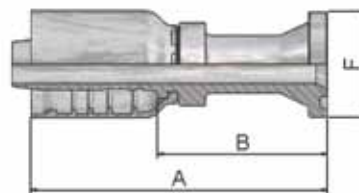



Part Number	Hose I.D.				A mm	B mm
	DN	Inch	Size	mm		
1K577-16-16	25	1	-16	25.4	119	65

Approved **fitting series** for hose types:

77 787TC | 797TC

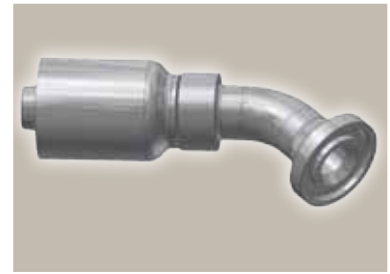
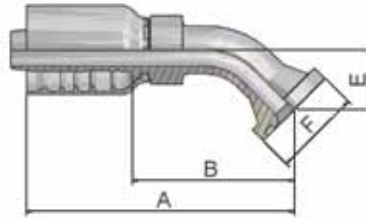
K7 Komatsu® Flange
45° Elbow



Part Number	 Hose I.D.				A mm	B mm	E mm
	DN	Inch	Size	mm			
1K777-12-12	19	3/4	-12	19.1	116	70	26
1K777-20-20	31	1 1/4	-20	31.8	159	96	38

K9 Komatsu® Flange
90° Elbow

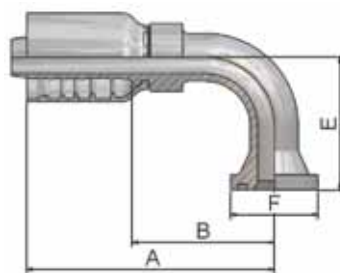

Part Number	 Hose I.D.				A mm	B mm	E mm
	DN	Inch	Size	mm			
1K977-12-12	19	3/4	-12	19.1	108	62	58
1K977-16-16	25	1	-16	25.4	127	73	70
1K977-20-20	31	1 1/4	-20	31.8	148	84	90

Approved **fitting series** for hose types:

 77 787TC | 797TC

JC

Female ORFS Swivel – Straight Short

ISO 12151-1 – SWSA
SAE J516 – ORFS

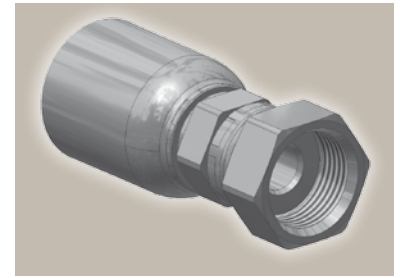
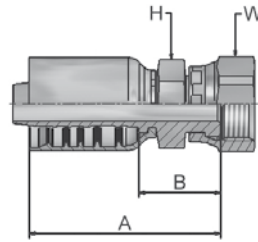

Part Number	Hose I.D.				Thread UNF	A mm	B mm	H mm	W mm
	DN	Inch	Size	mm					
1JC77-8-8	12	1/2	-8	12.7	13/16x16	60	25	22	24
1JC77-12-8	12	1/2	-8	12.7	1-3/16x12	64	29	30	36
1JC77-10-10	16	5/8	-10	15.9	1x14	70	31	24	30
1JC77-12-10	16	5/8	-10	15.9	13/16x16	69	30	30	36
1JC77-10-12	19	3/4	-12	19.1	1x14	79	33	30	30
1JC77-12-12	19	3/4	-12	19.1	1-3/16x12	79	33	30	36
1JC77-16-12	19	3/4	-12	19.1	1-7/16x12	81	35	36	41
1JC77-12-16	25	1	-16	25.4	1-3/16x12	92	38	36	36
1JC77-16-16	25	1	-16	25.4	1-7/16x12	91	37	36	41
1JC77-20-16	25	1	-16	25.4	1-11/16x12	90	36	41	50
1JC77-24-24	38	1 1/2	-24	38.1	2x12	109	43	50	-
1JC77-32-32	51	2	-32	50.8	2-1/2x12	143	66	65	75

J7

Female ORFS – Swivel 45° Elbow

ISO 12151-1 – SWE 45°
SAE J516 – ORFS 45°

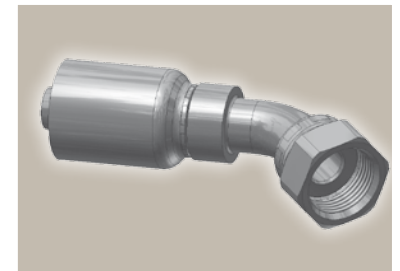
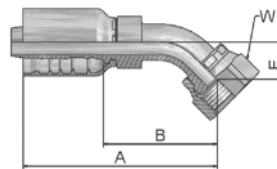

Part Number	Hose I.D.				Thread UNF	A mm	B mm	E mm	W mm
	DN	Inch	Size	mm					
1J777-8-8	12	1/2	-8	12.7	13/16x16	73	38	15	24
1J777-10-10	16	5/8	-10	15.9	1x14	93	54	16	30
1J777-12-12	19	3/4	-12	19.1	1-3/16x12	111	65	21	36
1J777-16-16	25	1	-16	25.4	1-7/16x12	133	79	24	41
1J777-20-20	31	1 1/4	-20	31.8	1-11/16x12	145	81	25	50
1J777-24-20	31	1 1/4	-20	31.8	2x12	148	84	27	60
1J777-24-24	38	1 1/2	-24	38.1	2x12	176	109	42	60

Approved **fitting series** for hose types:

77 787TC 797TC

J9 Female ORFS – Swivel 90° Elbow – Short Drop

ISO 12151-1 – SWES
SAE J516 – ORFS 90°

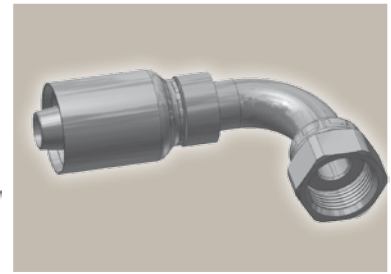
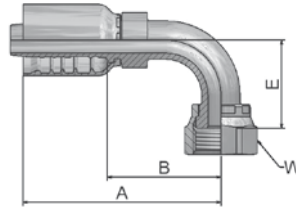

Part Number	Hose I.D.				Thread UNF	A mm	B mm	E mm	W mm
	DN	Inch	Size	mm					
1J977-8-8	12	1/2	-8	12.7	13/16x16	71	36	29	24
1J977-12-12	19	3/4	-12	19.1	1-3/16x12	108	62	48	36
1J977-16-12	19	3/4	-12	19.1	1-7/16x12	108	62	56	41
1J977-16-16	25	1	-16	25.4	1-7/16x12	131	77	56	41
1J977-20-20	31	1 1/4	-20	31.8	1-11/16x12	146	82	64	50
1J977-24-24	38	1 1/2	-24	38.1	2x12	163	96	69	60

JM ORFS Male

ISO 12151-1-S – SAE J516

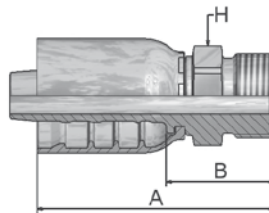

Part Number	Hose I.D.				Thread UNF	A mm	B mm	H mm
	DN	Inch	Size	mm				
1JM77-8-8	12	1/2	-8	12.7	13/16x16	63	28	22
1JM77-12-8	12	1/2	-8	12.7	1-3/16x12	70	35	32
1JM77-10-10	16	5/8	-10	15.9	1x14	72	33	27
1JM77-12-12	19	3/4	-12	19.1	1-3/16x12	83	37	32
1JM77-16-12	19	3/4	-12	19.1	1-7/16x12	84	38	41
1JM77-16-16	25	1	-16	25.4	1-7/16x12	96	41	41
1JM77-20-16	25	1	-16	25.4	1-11/16x12	93	39	46
1JM77-20-20	31	1 1/4	-20	31.8	1-11/16x12	110	46	50
1JM77-24-20	31	1 1/4	-20	31.8	2x12	117	52	60

JM fittings are supplied without O-ring.
Find O-rings in section E. Special O-rings are available on request.

Approved **fitting series** for hose types:

77 787TC | 797TC

Super Steck0®

Page Cf-1

A0

Cf-1



Super Steck0® fitting

DIN – Metric

Page Cf-2 – Cf-5

CA

Cf-2

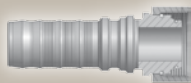

Female Metric 24°
Light Series with O-Ring
Swivel – Straight
ISO 12151-2-SWS-L – DKOL

CE

Cf-2

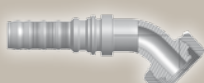

Female Metric 24°
Light Series with O-Ring
Swivel – 45° Elbow
ISO 12151-2-SWE 45°-L – DKOL 45°

CF

Cf-3

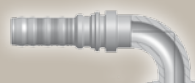

Female Metric 24°
Light Series with O-Ring
Swivel – 90° Elbow
ISO 12151-2-SWE-L – DKOL 90°

C9

Cf-4

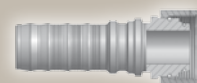

Female Metric 24° – Swivel
Heavy Series with O-Ring
Straight
ISO 12151-2-SWS-S – DKOS

OC

Cf-4



Female Metric 24° – Swivel
Heavy Series with O-Ring
45° Elbow
ISO 12151-2 – SWE 45°-S – DKOS 45°

1C

Cf-5



Female Metric 24° – Swivel
Heavy Series with O-Ring
90° Elbow
ISO 12151-2-SWE-S – DKOS 90°

D2

Cf-5

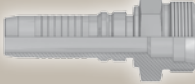

Male Metric 24° – Rigid
Heavy Series – Straight
ISO 12151-2-S-S – CES

BSP

Page Cg-6 – Cf-8

92

Cf-6

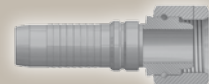

Female BSP Parallel Pipe
Swivel – Straight (60° Cone)
BS5200-A – DKR

B1

Cf-6



Female BSP Parallel Pipe
Swivel
45° Elbow (60° Cone)
BS 5200-D – DKR 45°

B2

Cf-7



Female BSP Parallel Pipe
Swivel
90° Elbow (60° Cone)
BS 5200-B – DKR 90°

D9

Cf-7

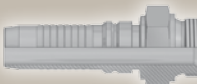

Male BSP Parallel Pipe
Rigid – Straight (60° Cone)
BS5200 – AGR

91



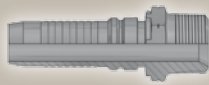

Cf-8

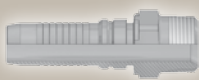

Male BSP Taper Pipe – Rigid
Straight
BS5200 – AGR-K

SAE

Page Cf-9 – Cf-11

<p>01 Cf-9</p>  <p>Male NPTF Pipe Rigid – Straight SAE J476A / J516 – AGN</p>	<p>03 Cf-9</p>  <p>Male JIC 37° – Rigid Straight ISO12151-5-S – AGJ</p>	<p>06 Cf-10</p>  <p>Female JIC 37° – Swivel Straight ISO12151-5-SWS – DKJ</p>	<p>37 Cf-10</p>  <p>Female JIC 37° – Swivel 45° Elbow ISO 12151-5-SWE 45° – DKJ 45°</p>
<p>39 Cf-11</p>  <p>Female JIC 37° – Swivel 90° Elbow ISO 12151-5-SWES – DKJ 90°</p>			

Flange

Page Cf-12 – Cf-21

<p>15/4A Cf-12</p>  <p>ISO 6162-1 Flange Straight ISO 12151-3-S-L – SFL (35.0 MPa/ 5000 psi)</p>	<p>17/4F Cf-13</p>  <p>ISO 6162-1 Flange 45° Elbow ISO 12151-3 – E45-S – L – SFL 45° (35.0 MPa/ 5000 psi)</p>	<p>19/4N Cf-14</p>  <p>ISO 6162-1 Flange 90° Elbow ISO 12151-3-E-L – SFL 90° (35.0 MPa/ 5000 psi)</p>
<p>6A Cf-15</p>  <p>ISO 6162-2 Flange Straight ISO 12151-3-S-S – SFS (42.0 MPa/ 6000 psi)</p>	<p>6F Cf-16</p>  <p>ISO 6162-2 Flange 45° Elbow – Heavy Series ISO 12151-3 – E45-S – SFS 45° (42.0 MPa/ 6000 psi)</p>	<p>6N Cf-17</p>  <p>ISO 6162-2 Flange 90° Elbow ISO 12151-3 – E-S – SFS 90° (42.0 MPa/ 6000 psi)</p>
<p>X5 Cf-19</p>  <p>Flange – Straight Full flange system for ISO 6162-1 or ISO 6162-2</p>	<p>X7 Cf-19</p>  <p>Flange – 45° Elbow Full flange system for ISO 6162-1 or ISO 6162-2</p>	<p>X9 Cf-20</p>  <p>Flange – 90° Elbow Full flange system for ISO 6162-1 or ISO 6162-2</p>
<p>XA Cf-20</p>  <p>Caterpillar® Flange Straight</p>	<p>XF Cf-21</p>  <p>Caterpillar® Flange 45° Elbow</p>	<p>XN Cf-21</p>  <p>Caterpillar® Flange 90° Elbow</p>

V4 Interlock In-/Outside Skive

4 Wire Hoses

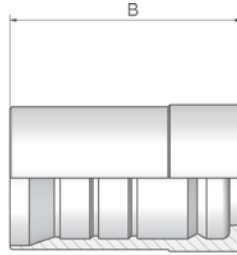

Only for use with adjustable crimpers.
Minimum of 320 tons crimping force recommended.

Part Number	 Hose I.D.				B mm
	DN	Inch	Size	mm	
100V4-10	16	5/8	-10	15.9	49
100V4-12	19	3/4	-12	19.1	60
100V4-16	25	1	-16	25.4	75
100V4-20	31	1 1/4	-20	31.8	88
100V4-24	38	1 1/2	-24	38.1	94
100V4-32	51	2	-32	50.8	99

Also available in stainless steel. Details can be found in CAT 4400.1/UK

V6 Interlock In-/Outside Skive

6 Wire Hoses



Only for use with adjustable crimpers.
Minimum of 340 tons crimping force required.

Part Number	 Hose I.D.				B mm
	DN	Inch	Size	mm	
100V6-20	31	1 1/4	-20	31.8	90
100V6-24	38	1 1/2	-24	38.1	96
100V6-32	51	2	-32	50.8	110
100V6-40	63	2 1/2	-40	63.5	134
100V6-48	76	3	-48	76.2	110

Also available in stainless steel. Details can be found in CAT 4400.1/UK

Approved **fitting series** for hose types:

Also available in stainless steel. Details can be found in CAT 4400.1/UK

V4 CM4R42P

V6 CM6R42P R35TC RS35TC

A0 Super SteckO® fitting

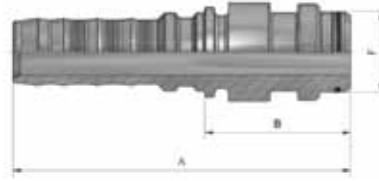

Part Number	Hose I.D.				A mm	B mm	F mm
	DN	Inch	Size	mm			
KA0V4-16-16-DR	25	1	-16	25.4	143	70	31
KA0V6-20-20	31	1 1/4	-20	31.8	158	70	38
KA0V6-24-24	38	1 1/2	-24	38.1	172	76	44
KA0V6-32-32-DR	51	2	-32	50.8	202	92	50

Approved **fitting series** for hose types:

Also available in stainless steel. Details can be found in CAT 4400.1/UK

V4	CM4R42P
V6	CM6R42P R35TC RS35TC

CA Female Metric 24° Light Series with O-Ring Swivel – Straight

ISO 12151-2-SWS-L – DKOL

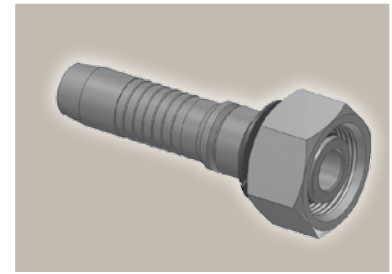
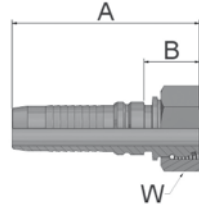

Part Number	Hose I.D.				Thread metric	Tube O.D. mm	A mm	B mm	W mm
	DN	Inch	Size	mm					
KCAV4-18-10	16	5/8	-10	15.9	M26x1.5	18	83	23	32
KCAV4-22-12	19	3/4	-12	19.1	M30x2	22	89	28	36
KCAV4-28-16	25	1	-16	25.4	M36x2	28	103	31	41
KCAV4-35-20	31	1 1/4	-20	31.8	M45x2	35	120	32	50
KCAV6-35-20	31	1 1/4	-20	31.8	M45x2	35	130	39	50
KCAV4-42-24	38	1 1/2	-24	38.1	M52x2	42	128	35	60
KCAV6-42-24	38	1 1/2	-24	38.1	M52x2	42	138	42	60

Fittings with standard O-ring seals can be used for temperatures from -40 °C up to +105 °C.
Find O-rings in section F. Special O-rings are available on request.

CE Female Metric 24° Light Series with O-Ring Swivel – 45° Elbow

ISO 12151-2-SWE 45°-L – DKOL 45°

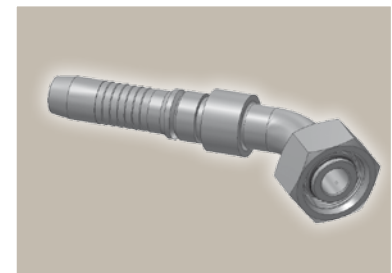
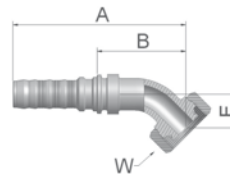

Part Number	Hose I.D.				Thread metric	Tube O.D. mm	A mm	B mm	E mm	W mm
	DN	Inch	Size	mm						
KCEV4-22-12	19	3/4	-12	19.1	M30x2	22	137	75	29	36
KCEV4-35-20	31	1 1/4	-20	31.8	M45x2	35	197	109	37	50
KCEV6-35-20	31	1 1/4	-20	31.8	M45x2	35	188	97	37	50
KCEV6-42-24	38	1 1/2	-24	38.1	M52x2	42	226	130	49	60

Fittings with standard O-ring seals can be used for temperatures from -40 °C up to +105 °C.
Find O-rings in section F. Special O-rings are available on request.

Approved **fitting series** for hose types:

Also available in stainless steel. Details can be found in CAT 4400.1/UK

V4	CM4R42P
V6	CM6R42P R35TC RS35TC

CF **Female Metric 24°
Light Series with O-Ring
Swivel – 90° Elbow**

ISO 12151-2-SWE-L – DKOL 90°

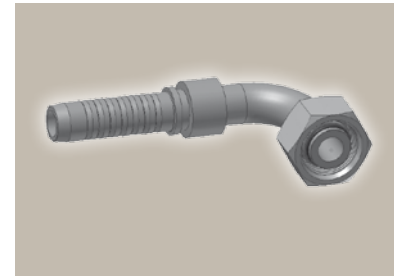
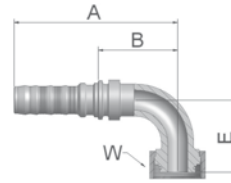

Part Number	Hose I.D.				Thread metric	Tube O.D. mm	A mm	B mm	E mm	W mm
	DN	Inch	Size	mm						
KCFV4-22-16	25	1	-16	25.4	M30x2	22	150	77	70	36
KCFV4-35-20	31	1 1/4	-20	31.8	M45x2	35	186	98	79	50
KCFV6-35-20	31	1 1/4	-20	31.8	M45x2	35	177	86	79	50
KCFV6-42-24	38	1 1/2	-24	38.1	M52x2	42	209	113	101	60

Fittings with standard O-ring seals can be used for temperatures from -40 °C up to +105 °C.
Find O-rings in section F. Special O-rings are available on request.

Approved **fitting series** for hose types:

Also available in stainless steel. Details can be found in CAT 4400.1/UK

V4	CM4R42P
V6	CM6R42P R35TC RS35TC

C9 Female Metric 24° – Swivel Heavy Series with O-Ring Straight

ISO 12151-2-SWS-S – DKOS

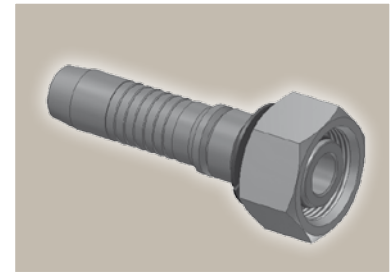
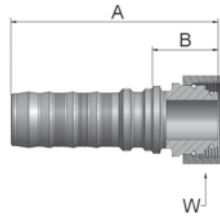

Part Number	Hose I.D.				Thread metric	Tube O.D. mm	A mm	B mm	W mm
	DN	Inch	Size	mm					
KC9V4-20-10	16	5/8	-10	15.9	M30x2	20	87	27	36
KC9V4-20-12	19	3/4	-12	19.1	M30x2	20	88	26	36
KC9V4-25-12	19	3/4	-12	19.1	M36x2	25	91	30	46
KC9V4-30-12	19	3/4	-12	19.1	M42x2	30	95	33	50
KC9V4-25-16	25	1	-16	25.4	M36x2	25	103	30	46
KC9V4-30-16	25	1	-16	25.4	M42x2	30	108	35	50
KC9V4-38-16	25	1	-16	25.4	M52x2	38	110	37	60
KC9V4-30-20	31	1 1/4	-20	31.8	M42x2	30	123	35	50
KC9V6-30-20	31	1 1/4	-20	31.8	M42x2	30	131	41	50
KC9V4-38-20	31	1 1/4	-20	31.8	M52x2	38	126	38	60
KC9V6-38-20	31	1 1/4	-20	31.8	M52x2	38	135	44	60
KC9V4-38-24	38	1 1/2	-24	38.1	M52x2	38	129	36	60
KC9V6-38-24	38	1 1/2	-24	38.1	M52x2	38	139	43	60
KC9V6-54-32	51	2	-32	50.8	M68x2	54	175	60	80

OC Female Metric 24° – Swivel Heavy Series with O-Ring 45° Elbow

ISO 12151-2 – SWE 45°-S – DKOS 45°

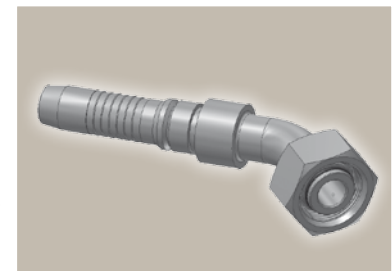
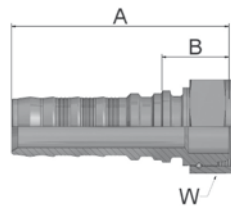

Part Number	Hose I.D.				Thread metric	Tube O.D. mm	A mm	B mm	E mm	W mm
	DN	Inch	Size	mm						
KOCV4-20-10	16	5/8	-10	15.9	M30x2	20	124	63	26	36
KOCV4-20-12	19	3/4	-12	19.1	M30x2	20	138	76	30	36
KOCV4-25-12	19	3/4	-12	19.1	M36x2	25	127	64	29	46
KOCV4-25-16	25	1	-16	25.4	M36x2	25	160	87	33	46
KOCV4-30-16	25	1	-16	25.4	M42x2	30	162	89	33	50
KOCV4-30-20	31	1 1/4	-20	31.8	M42x2	30	193	105	34	50
KOCV6-30-20	31	1 1/4	-20	31.8	M42x2	30	184	93	34	50
KOCV4-38-20	31	1 1/4	-20	31.8	M52x2	38	197	109	37	60
KOCV6-38-20	31	1 1/4	-20	31.8	M52x2	38	187	96	37	60
KOCV4-38-24	38	1 1/2	-24	38.1	M52x2	38	228	134	49	60
KOCV6-38-24	38	1 1/2	-24	38.1	M52x2	38	226	130	49	60

Fittings with standard O-ring seals can be used for temperatures from -40 °C up to +105 °C.
Find O-rings in section F. Special O-rings are available on request.

Also available in stainless steel. Details can be found in CAT 4400.1/UK

Approved **fitting series** for hose types:

V4	CM4R42P
V6	CM6R42P R35TC RS35TC

1C Female Metric 24° – Swivel Heavy Series with O-Ring 90° Elbow

ISO 12151-2-SWE-S – DKOS 90°

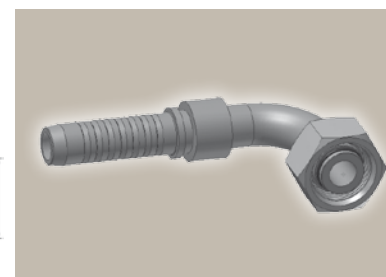
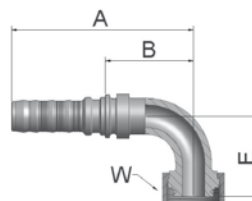

Part Number	Hose I.D.				Thread metric	Tube O.D. mm	A mm	B mm	E mm	W mm
	DN	Inch	Size	mm						
K1CV4-20-10	16	5/8	-10	15.9	M30x2	20	112	52	50	36
K1CV4-20-12	19	3/4	-12	19.1	M30x2	20	125	63	60	36
K1CV4-25-12	19	3/4	-12	19.1	M36x2	25	126	63	59	46
K1CV4-25-16	25	1	-16	25.4	M36x2	25	150	77	66	46
K1CV4-30-16	25	1	-16	25.4	M42x2	30	151	78	69	50
K1CV4-30-16-SL150	25	1	-16	25.4	M42x2	30	151	78	150	50
K1CV4-30-16-SL160	25	1	-16	25.4	M42x2	30	151	78	160	50
K1CV4-38-16	25	1	-16	25.4	M52x2	38	154	81	75	60
K1CV4-30-20	31	1 1/4	-20	31.8	M42x2	30	183	95	73	50
K1CV6-30-20	31	1 1/4	-20	31.8	M42x2	30	169	78	69	50
K1CV4-38-20	31	1 1/4	-20	31.8	M52x2	38	187	99	78	60
K1CV6-38-20	31	1 1/4	-20	31.8	M52x2	38	177	86	78	60
K1CV6-38-20-SL150	31	1 1/4	-20	31.8	M52x2	38	177	86	150	60
K1CV4-38-24	38	1 1/2	-24	38.1	M52x2	38	210	117	101	60
K1CV6-38-24	38	1 1/2	-24	38.1	M52x2	38	209	113	101	60

D2 Male Metric 24° – Rigid Heavy Series – Straight

ISO 12151-2-S-S – CES

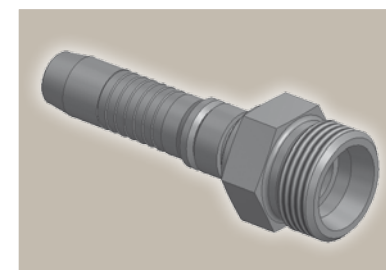
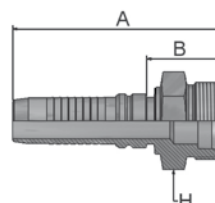

Part Number	Hose I.D.				Thread metric	Tube O.D. mm	A mm	B mm	H mm
	DN	Inch	Size	mm					
KD2V4-20-10	16	5/8	-10	15.9	M30x2	20	95	31	30
KD2V4-20-12	19	3/4	-12	19.1	M30x2	20	93	31	30
KD2V4-25-12	19	3/4	-12	19.1	M36x2	25	98	36	36
KD2V4-25-16	25	1	-16	25.4	M36x2	25	110	38	46
KD2V4-30-16	25	1	-16	25.4	M42x2	30	115	42	46
KD2V6-30-20	31	1 1/4	-20	31.8	M42x2	30	140	59	46
KD2V4-38-20	31	1 1/4	-20	31.8	M52x2	38	135	47	55
KD2V6-38-20	31	1 1/4	-20	31.8	M52x2	38	142	51	55
KD2V4-38-24	38	1 1/2	-24	38.1	M52x2	38	139	46	55
KD2V6-38-24	38	1 1/2	-24	38.1	M52x2	38	151	55	55

Approved fitting series for hose types:

Also available in stainless steel. Details can be found in CAT 4400.1/UK

V4 CM4R42P

V6 CM6R42P R35TC RS35TC

92 Female BSP Parallel Pipe Swivel – Straight (60° Cone)

BS5200-A – DKR

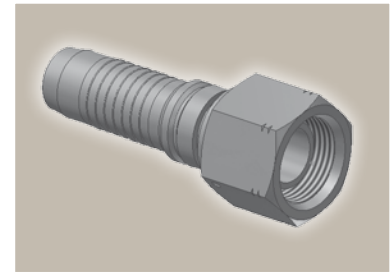
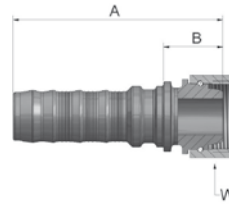

Part Number	Hose I.D.				Thread BSP	A mm	B mm	W mm
	DN	Inch	Size	mm				
K92V4-10-10	16	5/8	-10	15.9	5/8x14	80	20	30
K92V4-12-12	19	3/4	-12	19.1	3/4x14	85	23	32
K92V4-16-12	19	3/4	-12	19.1	1x11	93	31	41
K92V4-16-16	25	1	-16	25.4	1x11	105	32	41
K92V4-20-20	31	1 1/4	-20	31.8	1-1/4x11	118	30	50
K92V6-20-20	31	1 1/4	-20	31.8	1-1/4x11	127	36	50
K92V4-24-24	38	1 1/2	-24	38.1	1-1/2x11	124	31	55
K92V6-24-24	38	1 1/2	-24	38.1	1-1/2x11	134	38	55
K92V4-32-32	51	2	-32	50.8	2x11	131	34	70
K92V6-32-32	51	2	-32	50.8	2x11	151	41	70

B1 Female BSP Parallel Pipe Swivel 45° Elbow (60° Cone)

BS 5200-D – DKR 45°

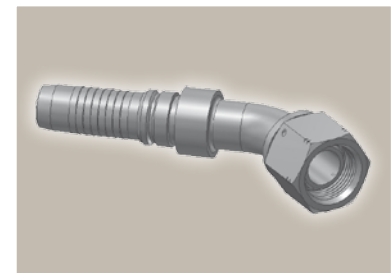
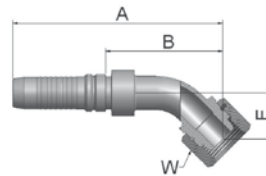

Part Number	Hose I.D.				Thread BSP	A mm	B mm	E mm	W mm
	DN	Inch	Size	mm					
KB1V4-12-12	19	3/4	-12	19.1	3/4x14	134	72	26	32
KB1V4-16-16	25	1	-16	25.4	1x11	164	91	36	41
KB1V4-20-20	31	1 1/4	-20	31.8	1-1/4x11	198	110	38	50
KB1V6-20-20	31	1 1/4	-20	31.8	1-1/4x11	194	103	43	50
KB1V4-24-24	38	1 1/2	-24	38.1	1-1/2x11	230	137	52	55
KB1V6-24-24	38	1 1/2	-24	38.1	1-1/2x11	229	133	52	55
KB1V4-32-32	51	2	-32	50.8	2x11	277	180	70	70
KB1V6-32-32	51	2	-32	50.8	2x11	288	178	70	70

Approved **fitting series** for hose types:

Also available in stainless steel. Details can be found in CAT 4400.1/UK

V4	CM4R42P
V6	CM6R42P R35TC RS35TC

B2 Female BSP Parallel Pipe Swivel 90° Elbow (60° Cone)

BS 5200-B – DKR 90°

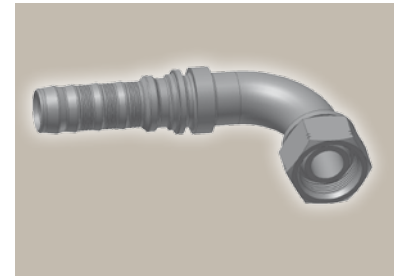
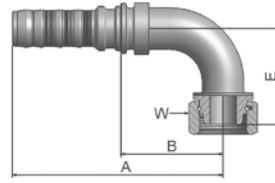

Part Number	Hose I.D.				Thread BSP	A mm	B mm	E mm	W mm
	DN	Inch	Size	mm					
KB2V4-12-12	19	3/4	-12	19.1	3/4x14	125	63	55	32
KB2V4-16-16	25	1	-16	25.4	1x11	150	77	74	41
KB2V4-20-20	31	1 1/4	-20	31.8	1-1/4x11	186	99	80	50
KB2V6-20-20	31	1 1/4	-20	31.8	1-1/4x11	177	86	80	50
KB2V4-24-24	38	1 1/2	-24	38.1	1-1/2x11	210	117	103	55
KB2V6-24-24	38	1 1/2	-24	38.1	1-1/2x11	209	113	103	55
KB2V4-32-32	51	2	-32	50.8	2x11	257	160	149	70
KB2V6-32-32	51	2	-32	50.8	2x11	268	157	149	70

D9 Male BSP Parallel Pipe Rigid – Straight (60° Cone)

BS5200 – AGR

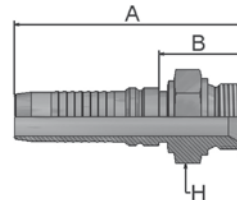

Part Number	Hose I.D.				Thread BSP	A mm	B mm	H mm
	DN	Inch	Size	mm				
KD9V4-10-10	16	5/8	-10	15.9	5/8x14	94	35	30
KD9V4-12-12	19	3/4	-12	19.1	3/4x14	99	37	32
KD9V4-16-16	25	1	-16	25.4	1x11	115	43	41
KD9V4-20-20	31	1 1/4	-20	31.8	1-1/4x11	134	46	50
KD9V6-20-20	31	1 1/4	-20	31.8	1-1/4x11	139	48	50
KD9V4-24-24	38	1 1/2	-24	38.1	1-1/2x11	142	48	55
KD9V6-24-24	38	1 1/2	-24	38.1	1-1/2x11	148	52	55
KD9V4-32-32	51	2	-32	50.8	2x11	148	50	70
KD9V6-32-32	51	2	-32	50.8	2x11	168	58	70

Approved **fitting series** for hose types:



Also available in stainless steel. Details can be found in CAT 4400.1/UK

V4	CM4R42P
V6	CM6R42P R35TC RS35TC

91 Male BSP Taper Pipe – Rigid Straight

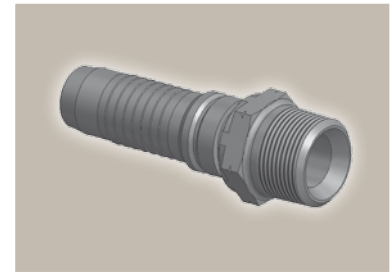
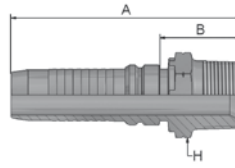
BS5200 – AGR-K



Part Number	 Hose I.D.				 Thread BSP	A mm	B mm	 H mm
	DN	Inch	Size	mm				
K91V4-12-12	19	3/4	-12	19.1	3/4x14	99	37	30
K91V4-16-16	25	1	-16	25.4	1x11	113	40	36
K91V4-20-20	31	1 1/4	-20	31.8	1-1/4x11	131	43	46
K91V4-24-24	38	1 1/2	-24	38.1	1-1/2x11	152	59	55
K91V4-32-32	51	2	-32	50.8	2x11	166	68	65

Approved **fitting series** for hose types:

Also available in stainless steel. Details can be found in CAT 4400.1/UK

V4 CM4R42P

V6 CM6R42P R35TC RS35TC

01

Male NPTF Pipe Rigid – Straight

SAE J476A / J516 – AGN

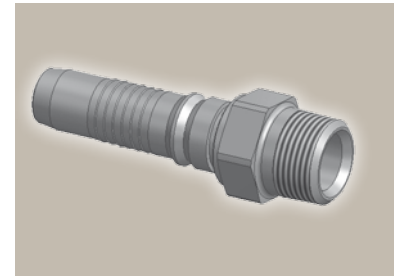
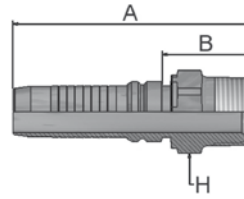

Part Number	Hose I.D.				Thread NPTF	A mm	B mm	H mm
	DN	Inch	Size	mm				
K01V4-12-12	19	3/4	-12	19.1	3/4x14	100	38	30
K01V4-16-16	25	1	-16	25.4	1x11-1/2	117	44	36
K01V4-20-20	31	1 1/4	-20	31.8	1-1/4x11-1/2	146	58	46
K01V6-20-20	31	1 1/4	-20	31.8	1-1/4x11-1/2	151	60	46
K01V4-24-24	38	1 1/2	-24	38.1	1-1/2x11-1/2	148	55	50
K01V6-24-24	38	1 1/2	-24	38.1	1-1/2x11-1/2	159	63	50
K01V4-32-32	51	2	-32	50.8	2x11-1/2	160	62	65
K01V6-32-32	51	2	-32	50.8	2x11-1/2	181	70	65

03

Male JIC 37° – Rigid Straight

ISO12151-5-S – AGJ

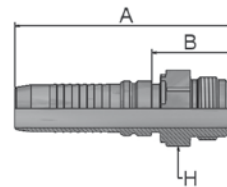

Part Number	Hose I.D.				Thread UNF	A mm	B mm	H mm
	DN	Inch	Size	mm				
K03V4-12-12	19	3/4	-12	19.1	1-1/16x12	101	39	30
K03V4-16-12	19	3/4	-12	19.1	1-5/16x12	103	41	36
K03V4-16-16	25	1	-16	25.4	1-5/16x12	117	44	36
K03V4-20-16	25	1	-16	25.4	1-5/8x12	122	50	46
K03V4-20-20	31	1 1/4	-20	31.8	1-5/8x12	139	51	46
K03V6-20-20	31	1 1/4	-20	31.8	1-5/8x12	147	56	46
K03V4-24-20	31	1 1/4	-20	31.8	1-7/8x12	139	51	50
K03V4-24-24	38	1 1/2	-24	38.1	1-7/8x12	146	53	50
K03V6-24-24	38	1 1/2	-24	38.1	1-7/8x12	156	60	50
K03V4-32-32	51	2	-32	50.8	2-1/2x12	161	64	65
K03V6-32-32	51	2	-32	50.8	2-1/2x12	182	72	65

Approved **fitting series** for hose types:

Also available in stainless steel. Details can be found in CAT 4400.1/UK

V4	CM4R42P
V6	CM6R42P R35TC RS35TC

06 Female JIC 37° – Swivel Straight

ISO12151-5-SWS – DKJ

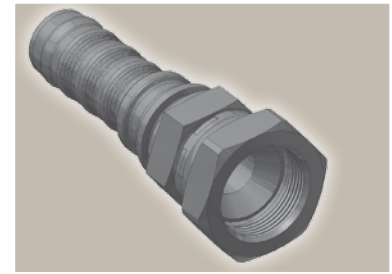
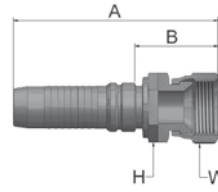

Part Number	Hose I.D.				Thread UNF	A mm	B mm	H mm	W mm
	DN	Inch	Size	mm					
K06V4-12-12	19	3/4	-12	19.1	1-1/16x12	105	43	30	32
K06V4-16-12	19	3/4	-12	19.1	1-5/16x12	109	48	36	41
K06V4-12-16	25	1	-16	25.4	1-1/16x12	121	49	36	32
K06V4-16-16	25	1	-16	25.4	1-5/16x12	122	50	36	41
K06V4-20-16	25	1	-16	25.4	1-5/8x12	125	52	41	50
K06V4-20-20	31	1 1/4	-20	31.8	1-5/8x12	146	58	46	50
K06V6-20-20	31	1 1/4	-20	31.8	1-5/8x12	154	63	46	50
K06V4-24-20	31	1 1/4	-20	31.8	1-7/8x12	150	63	50	60
K06V6-24-20	31	1 1/4	-20	31.8	1-7/8x12	159	68	50	60
K06V4-24-24	38	1 1/2	-24	38.1	1-7/8x12	152	59	50	60
K06V6-24-24	38	1 1/2	-24	38.1	1-7/8x12	163	67	50	60
K06V4-32-32	51	2	-32	50.8	2-1/2x12	168	77	65	75
K06V6-32-32	51	2	-32	50.8	2-1/2x12	188	78	65	75

37 Female JIC 37° – Swivel 45° Elbow

ISO 12151-5-SWE 45° – DKJ 45°

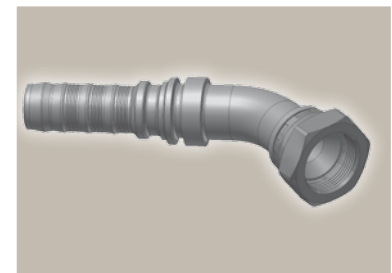
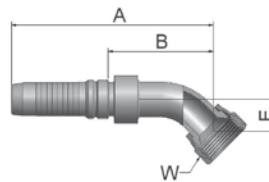

Part Number	Hose I.D.				Thread UNF	A mm	B mm	E mm	W mm
	DN	Inch	Size	mm					
K37V4-12-12	19	3/4	-12	19.1	1-1/16x12	128	67	21	32
K37V4-16-16	25	1	-16	25.4	1-5/16x12	152	80	24	41
K37V4-20-20	31	1 1/4	-20	31.8	1-5/8x12	201	113	42	50
K37V6-20-20	31	1 1/4	-20	31.8	1-5/8x12	192	101	42	50
K37V4-24-24	38	1 1/2	-24	38.1	1-7/8x12	227	134	49	60
K37V6-24-24	38	1 1/2	-24	38.1	1-7/8x12	235	139	58	60
K37V4-32-32	51	2	-32	50.8	2-1/2x12	279	182	72	75
K37V6-32-32	51	2	-32	50.8	2-1/2x12	290	180	72	75

Approved **fitting series** for hose types:

Also available in stainless steel. Details can be found in CAT 4400.1/UK

V4	CM4R42P
V6	CM6R42P R35TC RS35TC

39 Female JIC 37° – Swivel 90° Elbow

ISO 12151-5-SWES – DKJ 90°

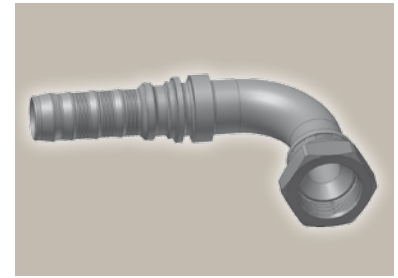
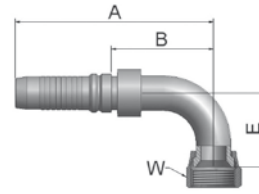

Part Number	Hose I.D.				Thread UNF	A mm	B mm	E mm	W mm
	DN	Inch	Size	mm					
K39V4-12-12	19	3/4	-12	19.1	1-1/16x12	125	63	48	32
K39V4-16-12	19	3/4	-12	19.1	1-5/16x12	125	63	56	41
K39V4-16-16	25	1	-16	25.4	1-5/16x12	150	78	56	41
K39V4-20-16	25	1	-16	25.4	1-5/8x12	150	77	62	50
K39V4-20-20	31	1 1/4	-20	31.8	1-5/8x12	186	98	85	50
K39V6-20-20	31	1 1/4	-20	31.8	1-5/8x12	177	86	85	50
K39V4-24-20	31	1 1/4	-20	31.8	1-7/8x12	186	98	80	60
K39V4-24-24	38	1 1/2	-24	38.1	1-7/8x12	210	117	102	60
K39V6-24-24	38	1 1/2	-24	38.1	1-7/8x12	209	113	102	60
K39V4-32-32	51	2	-32	50.8	2-1/2x12	257	160	152	75
K39V6-32-32	51	2	-32	50.8	2-1/2x12	268	157	152	75

Approved **fitting series** for hose types:

Also available in stainless steel. Details can be found in CAT 4400.1/UK

V4	CM4R42P
V6	CM6R42P R35TC RS35TC

15/4A ISO 6162-1 Flange Straight

ISO 12151-3-S-L – SFL

(35.0 MPa/ 5000 psi)

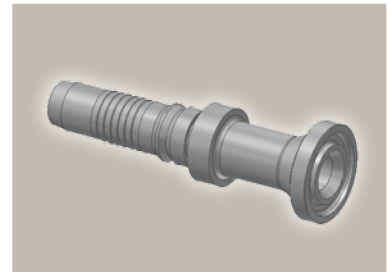
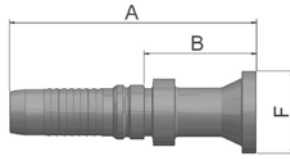

Part Number	Hose I.D.				Flange Inch	A mm	B mm	F mm
	DN	Inch	Size	mm				
K15V4-12-12	19	3/4	-12	19.1	3/4	119	58	38
K15V4-16-12	19	3/4	-12	19.1	1	100	38	45
K15V4-12-16	25	1	-16	25.4	3/4	135	62	38
K15V4-16-16	25	1	-16	25.4	1	133	61	45
K4AV4-20-16	25	1	-16	25.4	1-1/4	101	28	51
K15V4-16-20	31	1 1/4	-20	31.8	1	152	64	45
K15V6-16-20	31	1 1/4	-20	31.8	1	161	70	44
K4AV4-20-20	31	1 1/4	-20	31.8	1-1/4	160	72	51
K4AV6-20-20	31	1 1/4	-20	31.8	1-1/4	167	76	51
K4AV4-24-20	31	1 1/4	-20	31.8	1-1/2	126	39	60
K4AV6-24-20	31	1 1/4	-20	31.8	1-1/2	165	74	60
K4AV4-20-24	38	1 1/2	-24	38.1	1-1/4	167	73	51
K4AV4-24-24	38	1 1/2	-24	38.1	1-1/2	190	97	60
K4AV6-24-24	38	1 1/2	-24	38.1	1-1/2	201	105	60
K4AV4-32-24	38	1 1/2	-24	38.1	2	149	56	71
K4AV6-32-24	38	1 1/2	-24	38.1	2	159	63	71
K4AV4-32-32	51	2	-32	50.8	2	189	92	71
K4AV6-32-32	51	2	-32	50.8	2	210	100	71

Find SAE flanges in section F.

Approved **fitting series** for hose types:

Also available in stainless steel. Details can be found in CAT 4400.1/UK

V4	CM4R42P
V6	CM6R42P R35TC RS35TC

17/4F ISO 6162-1 Flange 45° Elbow

ISO 12151-3 – E45S – L – SFL 45°
(35.0 MPa/ 5000 psi)

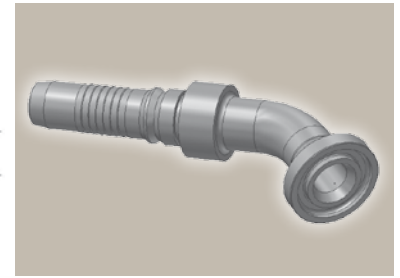
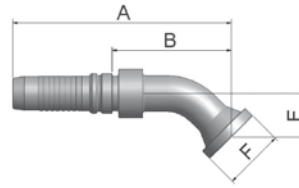

Part Number	Hose I.D.				Flange Inch	A mm	B mm	E mm	F mm
	DN	Inch	Size	mm					
K17V4-12-12	19	3/4	-12	19.1	3/4	133	71	26	38
K17V4-16-12	19	3/4	-12	19.1	1	133	71	26	45
K17V4-16-16	25	1	-16	25.4	1	160	88	32	45
K17V4-16-20	31	1 1/4	-20	31.8	1	198	110	38	45
K17V6-16-20	31	1 1/4	-20	31.8	1	188	97	38	44
K4FV4-20-12	19	3/4	-12	19.1	1-1/4	133	71	25	51
K4FV4-20-16	25	1	-16	25.4	1-1/4	160	88	32	51
K4FV4-20-20	31	1 1/4	-20	31.8	1-1/4	198	110	38	51
K4FV6-20-20	31	1 1/4	-20	31.8	1-1/4	188	97	38	51
K4FV4-24-20	31	1 1/4	-20	31.8	1-1/2	198	110	38	60
K4FV6-24-20	31	1 1/4	-20	31.8	1-1/2	188	97	38	60
K4FV4-20-24	38	1 1/2	-24	38.1	1-1/4	214	121	44	51
K4FV6-20-24	38	1 1/2	-24	38.1	1-1/4	201	105	44	51
K4FV4-24-24	38	1 1/2	-24	38.1	1-1/2	222	129	44	60
K4FV6-24-24	38	1 1/2	-24	38.1	1-1/2	221	125	44	60
K4FV4-32-24	38	1 1/2	-24	38.1	2	222	129	44	71
K4FV6-32-24	38	1 1/2	-24	38.1	2	221	125	44	71
K4FV4-32-32	51	2	-32	50.8	2	269	171	62	71
K4FV6-32-32	51	2	-32	50.8	2	274	164	56	71

Find SAE flanges in section F.

Approved **fitting series** for hose types:

Also available in stainless steel. Details can be found in CAT 4400.1/UK

V4	CM4R42P
V6	CM6R42P R35TC RS35TC

19/4N ISO 6162-1 Flange 90° Elbow

ISO 12151-3-E-L – SFL 90°

(35.0 MPa/ 5000 psi)

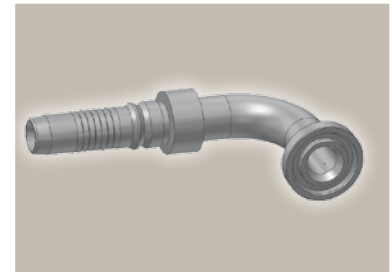
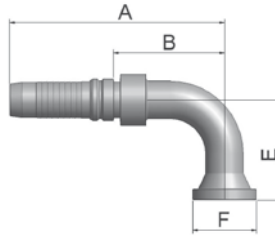

Part Number	Hose I.D.				Flange Inch	A mm	B mm	E mm	F mm
	DN	Inch	Size	mm					
K19V4-12-12	19	3/4	-12	19.1	3/4	125	63	58	38
K19V4-12-12-SL100	19	3/4	-12	19.1	3/4	125	63	100	38
K19V4-16-12	19	3/4	-12	19.1	1	125	63	58	45
K19V4-16-16	25	1	-16	25.4	1	150	78	70	45
K19V4-16-16-SL130	25	1	-16	25.4	1	150	78	130	45
K19V4-16-16-SL210	25	1	-16	25.4	1	150	78	210	45
K19V4-16-20	31	1 1/4	-20	31.8	1	186	99	90	45
K19V6-16-20	31	1 1/4	-20	31.8	1	177	86	90	44
K4NV4-20-12-SL65	19	3/4	-12	19.1	3/4	125	63	65	51
K4NV4-20-16	25	1	-16	25.4	1-1/4	150	78	68	51
K4NV4-20-16-SL130	25	1	-16	25.4	1-1/4	150	78	130	51
K4NV4-20-20	31	1 1/4	-20	31.8	1-1/4	186	99	90	51
K4NV4-20-20-SL120	31	1 1/4	-20	31.8	1-1/4	186	99	120	51
K4NV4-20-20-SL150	31	1 1/4	-20	31.8	1-1/4	186	99	150	51
K4NV4-20-20-SL165	31	1 1/4	-20	31.8	1-1/4	186	99	165	51
K4NV6-20-20	31	1 1/4	-20	31.8	1-1/4	177	86	90	51
K4NV4-24-20	31	1 1/4	-20	31.8	1-1/2	186	99	90	60
K4NV4-24-20-SL110	31	1 1/4	-20	31.8	1-1/2	186	99	110	60
K4NV4-24-20-SL150	31	1 1/4	-20	31.8	1-1/2	186	99	150	60
K4NV6-24-20	31	1 1/4	-20	31.8	1-1/2	177	86	90	60
K4NV6-24-20-SL200	31	1 1/4	-20	31.8	1-1/2	177	86	200	60
K4NV4-20-24	38	1 1/2	-24	38.1	1-1/4	197	104	104	51
K4NV6-20-24	38	1 1/2	-24	38.1	1-1/4	184	88	104	51
K4NV4-24-24	38	1 1/2	-24	38.1	1-1/2	210	117	104	60
K4NV4-24-24-SL150	38	1 1/2	-24	38.1	1-1/2	210	117	150	60
K4NV4-24-24-SL200	38	1 1/2	-24	38.1	1-1/2	210	117	200	60
K4NV4-24-24-SL250	38	1 1/2	-24	38.1	1-1/2	210	117	250	60
K4NV6-24-24	38	1 1/2	-24	38.1	1-1/2	209	113	104	60
K4NV6-24-24-SL200	38	1 1/2	-24	38.1	1-1/2	209	113	200	60
K4NV4-32-24	38	1 1/2	-24	38.1	2	210	117	104	71
K4NV6-32-24	38	1 1/2	-24	38.1	2	209	113	104	71
K4NV4-24-32	51	2	-32	50.8	1-1/2	227	130	138	60
K4NV4-24-32-SL160	51	2	-32	50.8	1-1/2	227	130	160	60
K4NV4-32-32	51	2	-32	50.8	2	257	160	138	71
K4NV6-32-32	51	2	-32	50.8	2	268	157	138	71

Find SAE flanges in section F.

Approved **fitting series** for hose types:

Also available in stainless steel. Details can be found in CAT 4400.1/UK

V4	CM4R42P
V6	CM6R42P R35TC RS35TC

6A ISO 6162-2 Flange Straight

ISO 12151-3-S-S – SFS

(42.0 MPa/ 6000 psi)

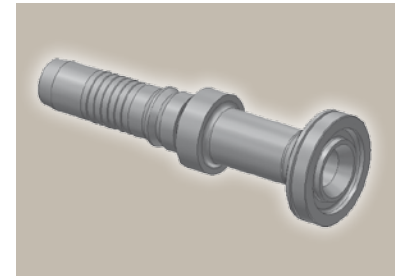
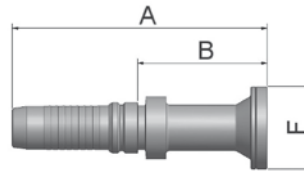

Part Number	Hose I.D.				Flange Inch	A mm	B mm	F mm
	DN	Inch	Size	mm				
K6AV4-8-10	16	5/8	-10	15.9	1/2	121	62	32
K6AV4-12-10	16	5/8	-10	15.9	3/4	94	34	41
K6AV4-12-12	19	3/4	-12	19.1	3/4	126	64	41
K6AV4-16-12	19	3/4	-12	19.1	1	100	38	48
K6AV4-12-16	25	1	-16	25.4	3/4	150	77	41
K6AV4-16-16	25	1	-16	25.4	1	148	75	48
K6AV4-20-16	25	1	-16	25.4	1-1/4	116	44	54
K6AV4-24-16	25	1	-16	25.4	1-1/2	118	45	64
K6AV4-16-20	31	1 1/4	-20	31.8	1	166	8	48
K6AV6-16-20	31	1 1/4	-20	31.8	1	175	84	48
K6AV4-20-20	31	1 1/4	-20	31.8	1-1/4	166	84	54
K6AV6-20-20	31	1 1/4	-20	31.8	1-1/4	175	83	54
K6AV4-24-20	31	1 1/4	-20	31.8	1-1/2	139	51	64
K6AV6-24-20	31	1 1/4	-20	31.8	1-1/2	147	56	64
K6AV4-20-24	38	1 1/2	-24	38.1	1-1/4	174	95	54
K6AV6-20-24	38	1 1/2	-24	38.1	1-1/4	185	89	54
K6AV4-24-24	38	1 1/2	-24	38.1	1-1/2	192	103	64
K6AV6-24-24	38	1 1/2	-24	38.1	1-1/2	201	106	64
K6AV4-32-24	38	1 1/2	-24	38.1	2	184	91	79
K6AV6-32-24	38	1 1/2	-24	38.1	2	194	98	79
K6AV4-24-32	51	2	-32	50.8	1-1/2	198	101	64
K6AV6-24-32	51	2	-32	50.8	1-1/2	219	108	64
K6AV4-32-32	51	2	-32	50.8	2	212	115	79
K6AV6-32-32	51	2	-32	50.8	2	233	122	79
K6AV6-40-40	63	2 1/2	-40	63.5	2 1/2	253	117	107
K6AV6-48-48	76	3	-48	76.2	3	240	133	132

Find SAE flanges in section F.

Approved **fitting series** for hose types:

Also available in stainless steel. Details can be found in CAT 4400.1/UK

V4	CM4R42P
V6	CM6R42P R35TC RS35TC

6F ISO 6162-2 Flange 45° Elbow – Heavy Series

ISO 12151-3 – E45-S – SFS 45°

(42.0 MPa/ 6000 psi)

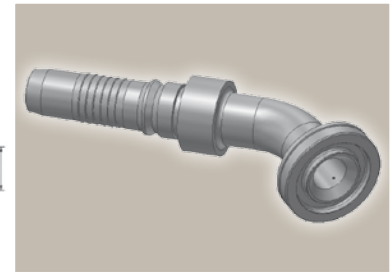
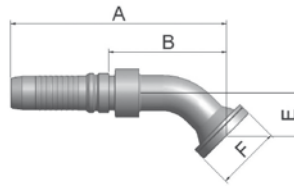

Part Number	Hose I.D.				Flange Inch	A mm	B mm	E mm	F mm
	DN	Inch	Size	mm					
K6FV4-8-10	16	5/8	-10	15.9	1/2	123	63	26	32
K6FV4-12-10	16	5/8	-10	15.9	3/4	123	63	26	41
K6FV4-12-12	19	3/4	-12	19.1	3/4	133	72	26	41
K6FV4-12-12-SL55	19	3/4	-12	19.1	3/4	162	101	55	41
K6FV4-16-12	19	3/4	-12	19.1	1	133	71	26	48
K6FV4-16-12-SL55	19	3/4	-12	19.1	1	162	101	55	48
K6FV4-12-16	25	1	-16	25.4	3/4	154	82	32	41
K6FV4-16-16	25	1	-16	25.4	1	160	88	32	48
K6FV4-20-16	25	1	-16	25.4	1-1/4	161	89	32	54
K6FV4-16-20	31	1 1/4	-20	31.8	1	198	110	38	48
K6FV6-16-20	31	1 1/4	-20	31.8	1	188	97	38	48
K6FV4-20-20	31	1 1/4	-20	31.8	1-1/4	198	110	38	54
K6FV4-20-20-SL60	31	1 1/4	-20	31.8	1-1/4	220	132	60	54
K6FV6-20-20	31	1 1/4	-20	31.8	1-1/4	189	97	38	54
K6FV6-20-20-SL60	31	1 1/4	-20	31.8	1-1/4	210	119	60	54
K6FV4-24-20	31	1 1/4	-20	31.8	1-1/2	198	110	38	64
K6FV4-24-20-SL60	31	1 1/4	-20	31.8	1-1/2	220	132	60	64
K6FV6-24-20	31	1 1/4	-20	31.8	1-1/2	189	97	38	64
K6FV4-20-24	38	1 1/2	-24	38.1	1-1/2	214	121	44	54
K6FV6-20-24	38	1 1/2	-24	38.1	1-1/4	209	113	44	54
K6FV4-24-24	38	1 1/2	-24	38.1	1-1/2	222	129	44	64
K6FV4-24-24-SL200	38	1 1/2	-24	38.1	1-1/2	222	129	200	64
K6FV4-24-24-SL60	38	1 1/2	-24	38.1	1-1/2	222	129	60	64
K6FV4-24-24-SL70	38	1 1/2	-24	38.1	1-1/2	248	155	70	64
K6FV6-24-24	38	1 1/2	-24	38.1	1-1/2	221	125	44	64
K6FV6-24-24-SL70	38	1 1/2	-24	38.1	1-1/2	221	125	70	64
K6FV4-32-24	38	1 1/2	-24	38.1	2	222	129	44	79
K6FV6-32-24	38	1 1/2	-24	38.1	2	221	125	44	79
K6FV4-24-32	51	2	-32	50.8	1-1/2	245	147	56	64
K6FV6-24-32	51	2	-32	50.8	1-1/2	260	149	56	64
K6FV4-32-32	51	2	-32	50.8	2	263	166	56	79
K6FV4-32-32-SL70	51	2	-32	50.8	2	277	180	70	79
K6FV6-32-32	51	2	-32	50.8	2	274	163	56	79

Find SAE flanges in section F.

Approved **fitting series** for hose types:

Also available in stainless steel. Details can be found in CAT 4400.1/UK

V4	CM4R42P
V6	CM6R42P R35TC RS35TC

6N

ISO 6162-2 Flange 90° Elbow

ISO 12151-3 – E-S – SFS 90°

(42.0 MPa/ 6000 psi)

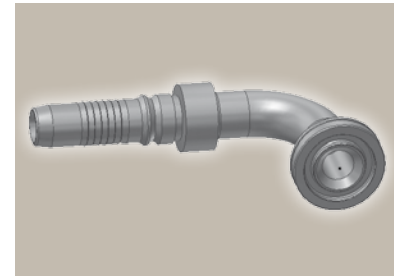
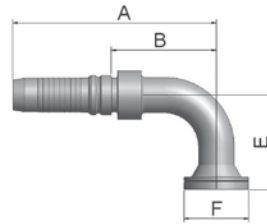

Part Number	Hose I.D.				Flange Inch	A mm	B mm	E mm	F mm
	DN	Inch	Size	mm					
K6NV4-8-10	16	5/8	-10	15.9	1/2	111	51	54	32
K6NV4-12-10	16	5/8	-10	15.9	3/4	111	50	54	41
K6NV4-12-12	19	3/4	-12	19.1	3/4	125	63	58	41
K6NV4-12-12-SL100	19	3/4	-12	19.1	3/4	125	63	100	41
K6NV4-12-12-SL70	19	3/4	-12	19.1	3/4	125	63	70	41
K6NV4-12-12-SL80	19	3/4	-12	19.1	3/4	125	63	80	41
K6NV4-12-12-SL86	19	3/4	-12	19.1	3/4	125	63	86	41
K6NV4-16-12	19	3/4	-12	19.1	1	125	63	58	48
K6NV4-16-12-SL100	19	3/4	-12	19.1	1	125	63	100	48
K6NV4-16-12-SL90	19	3/4	-12	19.1	1	125	63	90	48
K6NV4-12-16	25	1	-16	25.4	3/4	140	68	70	41
K6NV4-12-16-SL55	25	1	-16	25.4	3/4	140	68	55	41
K6NV4-12-16-SL80	25	1	-16	25.4	3/4	140	68	80	41
K6NV4-16-16	25	1	-16	25.4	1	150	78	70	48
K6NV4-16-16-SL110	25	1	-16	25.4	1	150	78	110	48
K6NV4-16-16-SL125	25	1	-16	25.4	1	150	78	125	48
K6NV4-16-16-SL140	25	1	-16	25.4	1	150	78	140	48
K6NV4-16-16-SL80	25	1	-16	25.4	1	150	78	80	48
K6NV4-20-16	25	1	-16	25.4	1-1/4	154	82	70	54
K6NV4-20-16-SL150	25	1	-16	25.4	1-1/4	154	82	150	54
K6NV4-20-16-SL175	25	1	-16	25.4	1-1/4	154	82	175	54
K6NV4-20-16-SL65	25	1	-16	25.4	1-1/4	154	82	65	54

Size -20 up to size -32:
please see next page!

Approved fitting series for hose types:

Also available in stainless steel. Details can be found in CAT 4400.1/UK



CM4R42P



CM6R42P R35TC RS35TC

6N ISO 6162-2 Flange 90° Elbow

ISO 12151-3 – E-S – SFS 90°

(42.0 MPa/ 6000 psi)

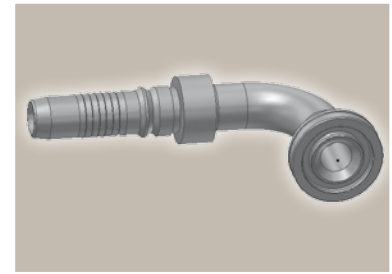
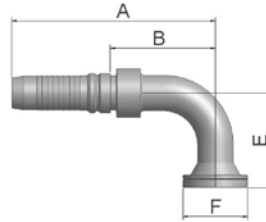

Part Number	Hose I.D.				Flange Inch	A mm	B mm	E mm	F mm
	DN	Inch	Size	mm					
K6NV4-16-20	31	1 1/4	-20	31.8	1	186	99	90	48
K6NV6-16-20	31	1 1/4	-20	31.8	1	177	86	90	48
K6NV4-20-20	31	1 1/4	-20	31.8	1-1/4	186	99	90	54
K6NV4-20-20-SL120	31	1 1/4	-20	31.8	1-1/4	186	98	120	54
K6NV4-20-20-SL140	31	1 1/4	-20	31.8	1-1/4	186	98	140	54
K6NV4-20-20-SL155	31	1 1/4	-20	31.8	1-1/4	186	98	155	54
K6NV4-20-20-SL200	31	1 1/4	-20	31.8	1-1/4	186	98	200	54
K6NV6-20-20	31	1 1/4	-20	31.8	1-1/4	177	86	90	54
K6NV6-20-20-SL120	31	1 1/4	-20	31.8	1-1/4	177	86	120	54
K6NV6-20-20-SL150	31	1 1/4	-20	31.8	1-1/4	177	86	150	54
K6NV4-24-20	31	1 1/4	-20	31.8	1-1/2	186	99	90	64
K6NV4-24-20-SL135	31	1 1/4	-20	31.8	1-1/2	186	98	135	64
K6NV6-24-20	31	1 1/4	-20	31.8	1-1/2	177	86	90	64
K6NV4-20-24	38	1 1/2	-24	38.1	1-1/4	197	104	104	54
K6NV6-20-24	38	1 1/2	-24	38.1	1-1/4	192	96	104	54
K6NV4-24-24	38	1 1/2	-24	38.1	1-1/2	210	117	104	64
K6NV4-24-24-SL140	38	1 1/2	-24	38.1	1-1/2	210	117	140	64
K6NV4-24-24-SL150	38	1 1/2	-24	38.1	1-1/2	210	117	150	64
K6NV4-24-24-SL160	38	1 1/2	-24	38.1	1-1/2	210	117	160	64
K6NV4-24-24-SL200	38	1 1/2	-24	38.1	1-1/2	210	117	200	64
K6NV4-24-24-SL250	38	1 1/2	-24	38.1	1-1/2	210	117	250	64
K6NV6-24-24	38	1 1/2	-24	38.1	1-1/2	210	113	104	64
K6NV6-24-24-SL190	38	1 1/2	-24	38.1	1-1/2	210	113	190	64
K6NV4-32-24	38	1 1/2	-24	38.1	2	210	117	104	79
K6NV6-32-24	38	1 1/2	-24	38.1	2	209	113	104	79
K6NV4-24-32	51	2	-32	50.8	1-1/2	221	124	104	64
K6NV6-24-32	51	2	-32	50.8	1-1/2	236	125	104	64
K6NV4-32-32	51	2	-32	50.8	2	257	160	138	79
K6NV6-32-32	51	2	-32	50.8	2	268	157	138	79
K6NV6-32-32-SL145	51	2	-32	50.8	2	268	157	145	79

Size -10 up to size -16:
please see previous page!

Approved fitting series for hose types:

Also available in stainless steel. Details can be found in CAT 4400.1/UK

V4	CM4R42P
V6	CM6R42P R35TC RS35TC

X5 Flange – Straight

Full flange system for
ISO 6162-1 or ISO 6162-2

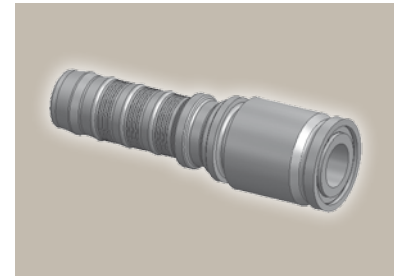
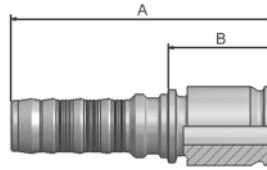

Part Number	Hose I.D.				Flange Inch	A mm	B mm
	DN	Inch	Size	mm			
KX5V6-20-20	31	1 1/4	-20	31.8	1-1/4	152	61
KX5V6-24-24	38	1 1/2	-24	38.1	1-1/2	159	63
KX5V6-32-32	51	2	-32	50.8	2	186	75
KX5V6-40-40	63	2 1/2	-40	63.5	2-1/2	233	98
KX5V6-48-48	76	3	-48	76.2	3	200	83

Find SAE flanges in section F.

X7 Flange – 45° Elbow

Full flange system for
ISO 6162-1 or ISO 6162-2

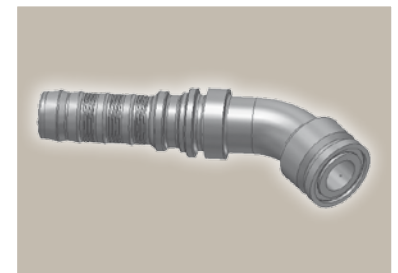
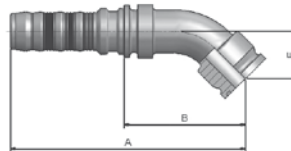

Part Number	Hose I.D.				Flange Inch	A mm	B mm	E mm
	DN	Inch	Size	mm				
KX7V6-20-20	31	1 1/4	-20	31.8	1-1/4	188	97	38
KX7V6-24-24	38	1 1/2	-24	38.1	1-1/2	221	125	44
KX7V6-32-32	51	2	-32	50.8	2	275	165	57

Find SAE flanges in section F.

Approved **fitting series** for hose types:

Also available in stainless steel. Details can be found in CAT 4400.1/UK

V4	CM4R42P
V6	CM6R42P R35TC RS35TC

X9 Flange – 90° Elbow

Full flange system for
ISO 6162-1 or ISO 6162-2

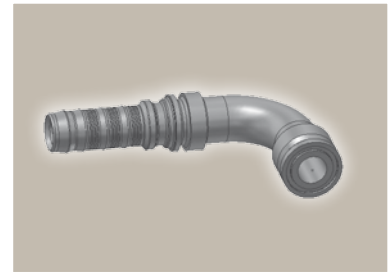
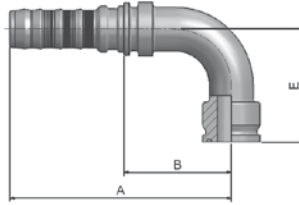

Part Number	Hose I.D.				Flange Inch	A mm	B mm	E mm
	DN	Inch	Size	mm				
KX9V6-20-20	31	1 1/4	-20	31.8	1-1/4	177	86	90
KX9V6-24-24	38	1 1/2	-24	38.1	1-1/2	209	113	104
KX9V6-32-32	51	2	-32	50.8	2	268	157	138

Find SAE flanges in section F.

XA Caterpillar® Flange Straight

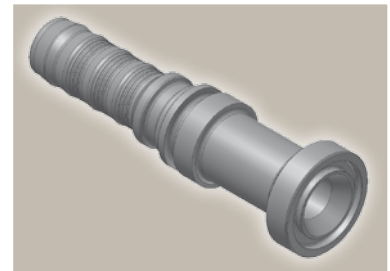
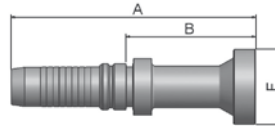

Part Number	Hose I.D.				Flange Inch	A mm	B mm	F mm
	DN	Inch	Size	mm				
KXAV4-12-12	19	3/4	-12	19.1	3/4	132	71	41
KXAV4-16-12	19	3/4	-12	19.1	1	144	82	48
KXAV4-16-16	25	1	-16	25.4	1	155	82	48
KXAV4-20-16	25	1	-16	25.4	1-1/4	160	88	54
KXAV6-20-20	31	1 1/4	-20	31.8	1-1/4	181	90	54
KXAV6-24-20	31	1 1/4	-20	31.8	1-1/2	188	97	64
KXAV6-24-24	38	1 1/2	-24	38.1	1-1/2	207	111	64

Approved **fitting series** for hose types:

Also available in stainless steel. Details can be found in CAT 4400.1/UK

V4 CM4R42P

V6 CM6R42P R35TC RS35TC

XF Caterpillar® Flange 45° Elbow

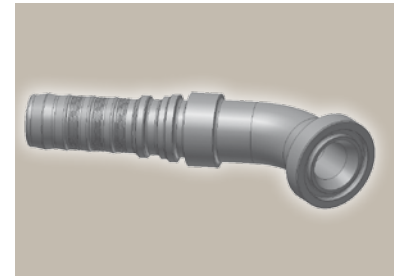
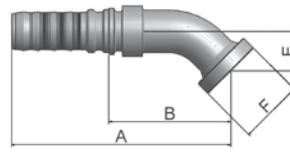

Part Number	Hose I.D.				Flange Inch	A mm	B mm	E mm	F mm
	DN	Inch	Size	mm					
KXFV4-12-12	19	3/4	-12	19.1	3/4	138	76	31	41
KXFV4-16-16	25	1	-16	25.4	1	164	91	36	48
KXFV4-20-16	25	1	-16	25.4	1-1/4	164	92	35	54
KXFV6-20-20	31	1 1/4	-20	31.8	1-1/4	187	96	37	54
KXFV6-24-20	31	1 1/4	-20	31.8	1-1/2	187	96	36	64
KXFV6-24-24	38	1 1/2	-24	38.1	1-1/2	216	120	39	64

XN Caterpillar® Flange 90° Elbow

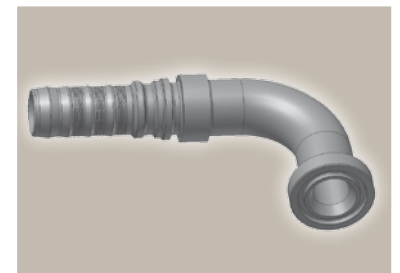
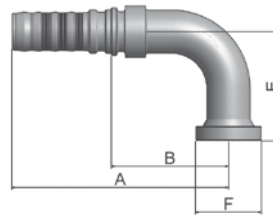

Part Number	Hose I.D.				Flange Inch	A mm	B mm	E mm	F mm
	DN	Inch	Size	mm					
KXNV4-12-12	19	3/4	-12	19.1	3/4	125	63	63	41
KXNV4-16-12	19	3/4	-12	19.1	1	125	63	62	48
KXNV4-16-16	25	1	-16	25.4	1	150	77	74	48
KXNV4-20-16	25	1	-16	25.4	1-1/4	154	81	74	54
KXNV6-20-20	31	1 1/4	-20	31.8	1-1/4	177	86	77	54
KXNV6-24-20	31	1 1/4	-20	31.8	1-1/2	177	86	77	64
KXNV6-24-24	38	1 1/2	-24	38.1	1-1/2	209	113	106	64

Approved **fitting series** for hose types:



Also available in stainless steel. Details can be found in CAT 4400.1/UK

V4 CM4R42P

V6 CM6R42P R35TC RS35TC

SteckO®

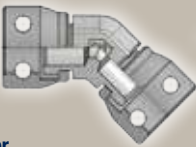
Page D-1 – D-16

<p>S27 D-1</p>  <p>SteckO® adaptor Banjo</p>	<p>S28 D-1</p>  <p>SteckO® adaptor Bonded Washer</p>	<p>S29 D-1</p>  <p>SteckO® adaptor Banjo Bolt</p>	<p>S30 D-2</p>  <p>SteckO® adaptor Straight - Fixed Female</p>
<p>S32 D-2</p>  <p>SteckO® adaptor Straight - Female Swivel</p>	<p>S35 D-3</p>  <p>SteckO® adaptor 45° Swivel Female</p>	<p>S40 D-3</p>  <p>SteckO® adaptor 90° Swivel Female</p>	<p>S45 D-4</p>  <p>SteckO® adaptor 90° Fixed Female</p>
<p>S50 D-4</p>  <p>SteckO® adaptor Swivel Female Tee</p>	<p>S55 D-5</p>  <p>SteckO® adaptor Swivel Female Tee</p>	<p>S60 D-5</p>  <p>SteckO® adaptor Cross - Fixed Demale</p>	<p>S70 D-6</p>  <p>SteckO® adaptor Straight Fixed Female</p>
<p>S72 D-6</p>  <p>SteckO® adaptor S-O Male - Swivel Female</p>	<p>S74 D-7</p>  <p>SteckO® adaptor 45° S-O Male - Swivel Female</p>	<p>S76 D-7</p>  <p>SteckO® adaptor 90° S-O Male - Swivel Female</p>	<p>S77 D-8</p>  <p>SteckO® adaptor S-O Male - Swivel Female Tee</p>
<p>S78 D-8</p>  <p>SteckO® adaptor S-O Male - Swivel Female L</p>	<p>S80 D-8</p>  <p>SteckO® adaptor Swivel Female - NPTF Male</p>	<p>S90 D-9</p>  <p>SteckO® adaptor 45° Swivel Female - NPTF Male</p>	<p>S95 D-9</p>  <p>SteckO® adaptor 90° Swivel Female - NPTF Male</p>
<p>S114 D-9</p>  <p>SteckO® adaptor S-O Swivel Female BSP Male</p>	<p>S115 D-10</p>  <p>SteckO® adaptor Swivel Female - BSP Male</p>	<p>S118 D-10</p>  <p>SteckO® adaptor 90° Swivel Female - BSP Swivel Female</p>	<p>S119 D-11</p>  <p>SteckO® adaptor 45° Swivel Female - BSP Swivel Female</p>
<p>S120 D-11</p>  <p>SteckO® adaptor Double S-O Male</p>	<p>S125 D-12</p>  <p>SteckO® adaptor S-O Male - NPTF Male</p>	<p>S140 D-12</p>  <p>SteckO® adaptor S-O Male - UNF Male O-Ring</p>	<p>S155 D-13</p>  <p>SteckO® adaptor S-O Male - BSP Male</p>
<p>S160 D-13</p>  <p>SteckO® Female End Cap</p>	<p>S165 D-14</p>  <p>SteckO® S-O Male Plug</p>	<p>S170 D-14</p>  <p>SteckO® Staple</p>	<p>S170ZN D-15</p>  <p>SteckO® Staple</p>
<p>S175 D-15</p>  <p>SteckO® Staple</p>	<p>S175D D-16</p>  <p>SteckO® Staple</p>	<p>S180 D-16</p>  <p>SteckO® O-Ring</p>	<p>S195 D-16</p>  <p>SteckO® Backup Ring</p>

S200

D-16

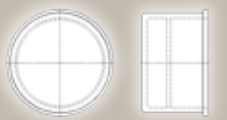

SteckO®
Plastic cap

SuperSteckO®

Page D-17 – D-23

<p>SS30 D-17</p> <p>Super SteckO® adaptor Straight SS-O Female</p>	<p>SS40 D-17</p> <p>Super SteckO® adaptor 90° SS-O Female</p>	<p>SS45 D-17</p> <p>Super SteckO® adaptor 90° SS-O Female</p>	<p>SS50 D-17</p> <p>Super SteckO® adaptor SS-O Female Tee</p>
<p>SS55 D-17</p> <p>Super SteckO® adaptor SS-O Female Tee</p>	<p>SS72 D-18</p> <p>Super SteckO® adaptor SS-O Male - S-O Female</p>	<p>SS76 D-18</p> <p>Super SteckO® adaptor 90° SS-O Male - Female</p>	<p>SS85 D-18</p> <p>Super SteckO® adaptor SS-O Female - NPTF Male</p>
<p>SS115 D-19</p> <p>Super SteckO® adaptor SS-O Female - BSP Male</p>	<p>SS120S D-19</p> <p>Super SteckO® adaptor SS-O - S-O Double Male</p>	<p>SS120 D-20</p> <p>Super SteckO® adaptor Double SS-O Male</p>	<p>SS125 D-20</p> <p>Super SteckO® adaptor SS-O Male - NPTF Male</p>
<p>SS155 D-21</p> <p>Super SteckO® adaptor SS-O Male - BSP Male</p>	<p>SS160 D-21</p> <p>Super SteckO® End cap</p>	<p>SS165 D-22</p> <p>Super SteckO® Male Plug</p>	<p>SS175D D-22</p> <p>Super SteckO® Staple</p>
<p>SS175 D-22</p> <p>Super SteckO® Staple</p>	<p>SS180 D-23</p> <p>Super SteckO® O-Ring</p>	<p>SS195 D-23</p> <p>Super SteckO® Backup Ring</p>	

S27 Stecko® adaptor

Banjo

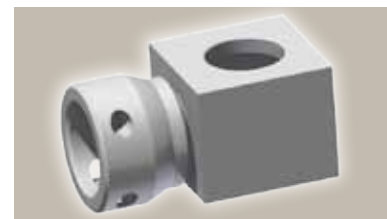
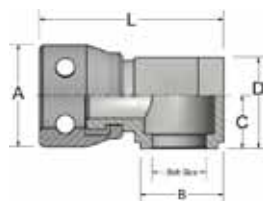

Part Number	Port Size				Bolt size BSP inch	L mm	A mm	B mm	C mm	D mm
	DN	Inch	Size	mm						
S27-4-4	6	1/4	-4	6.4	1/4	40	25	25.0	14.0	22.0
S27-6-6	10	3/8	-6	9.5	3/8	44	32	32.0	16.5	29.0
S27-6-8	10	3/8	-6	9.5	1/2	47	32	38.0	16.5	32.0
S27-8-6	12	1/2	-8	12.7	3/8	44	35	32.0	17.5	29.0
S27-8-8	12	1/2	-8	12.7	1/2	47	35	38.0	17.5	32.0
S27-12-12	19	3/4	-12	19.1	3/4	52	45	51.0	24.0	44.5
S27-16-16	25	1	-16	25.4	1	96	60	57.0	30.0	51.0
S27-20-20	31	1 1/4	-20	31.8	1 1/4	96	60	63.5	32.0	63.5

S28 Stecko® adaptor

Bonded Washer



Part Number	Bolt size	L mm	A mm
	BSP inch		
S28-4	1/4	2.1	20.6
S28-6	3/8	2.1	23.8
S28-8	1/2	2.5	28.6
S28-12	3/4	2.5	34.9
S28-16	1	3.3	42.8
S28-20	1 1/4	3.3	52.4
S28-24	1 1/2	3.3	58.6
S28-32	2	3.3	73.0

S29 Stecko® adaptor

Banjo Bolt

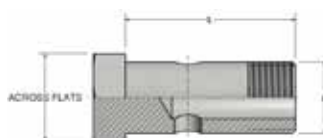

Part Number	Thread	L mm	AF inch
	BSP inch		
S29-4	1/4	35.9	3/4
S29-6	3/8	43.6	15/16
S29-8	1/2	49.9	1
S29-12	3/4	63.9	1 5/16
S29-16	1	74.6	1 11/16
S29-20	1 1/4	89.8	2 1/8

S30 SteckO® adaptor
Straight - Fixed Female

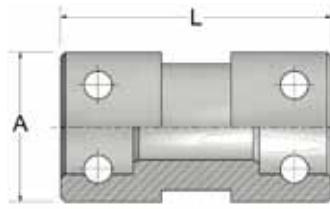

Part Number	Port Size				L mm	A mm
	DN	Inch	Size	mm		
S30-4-4	6	1/4	-4	6.4	58	25
S30-6-6	10	3/8	-6	9.5	58	32
S30-8-8	12	1/2	-8	12.7	59	35
S30-12-12	19	3/4	-12	19.1	59	45
S30-16-16	25	1	-16	25.4	67	55
S30-20-20	31	1 1/4	-20	31.8	67	60
S30-24-24	40	1 1/2	-24	38.1	80	80
S30-32-32	51	2	-32	50.8	80	90
S30-40-40	63	2 1/2	-40	63.5	136	100
S30-48-48	76	3	-48	76.2	190	120

S32 SteckO® adaptor
Straight - Female Swivel

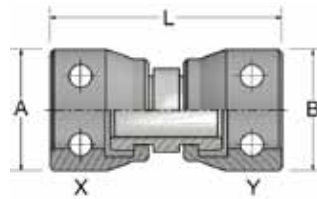

Part Number	Port Size				Y				L mm	A mm	B mm
	DN	Inch	Size	mm	DN	Inch	Size	mm			
S32-4-4	6	1/4	-4	6.4	6	1/4	-4	6.4	60	25	25
S32-6-4	10	3/8	-6	9.5	6	1/4	-4	6.4	60	32	32
S32-6-6	10	3/8	-6	9.5	10	3/8	-6	9.5	60	32	25
S32-8-4	12	1/2	-8	12.7	6	1/4	-4	6.4	60	35	25
S32-8-6	12	1/2	-8	12.7	10	3/8	-6	9.5	65	35	32
S32-8-8	12	1/2	-8	12.7	12	1/2	-8	12.7	60	35	35
S32-12-6	19	3/4	-12	19.1	10	3/8	-6	9.5	60	45	32
S32-12-8	19	3/4	-12	19.1	12	1/2	-8	12.7	65	45	35
S32-12-12	19	3/4	-12	19.1	19	3/4	-12	19.1	60	45	45
S32-16-6	25	1	-16	25.4	10	3/8	-6	9.5	60	45	32
S32-16-8	25	1	-16	25.4	12	1/2	-8	12.7	75	60	35
S32-16-12	25	1	-16	25.4	19	3/4	-12	19.1	70	60	45
S32-16-16	25	1	-16	25.4	25	1	-16	25.4	80	60	60
S32-20-12	31	1 1/4	-20	31.8	19	3/4	-12	19.1	70	60	45
S32-20-16	31	1 1/4	-20	31.8	25	1	-16	25.4	80	60	60
S32-20-20	31	1 1/4	-20	31.8	31	1 1/4	-20	31.8	80	60	80

S35 SteckO® adaptor

45° Swivel Female

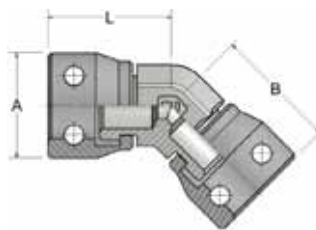

Part Number	Port Size				L mm	A mm	B mm
	DN	Inch	Size	mm			
S35-4-4	6	1/4	-4	6.4	45	25	39
S35-6-6	10	3/8	-6	9.5	48	32	42
S35-8-8	12	1/2	-8	12.7	50	35	42
S35-12-12	19	3/4	-12	19.1	53	45	42
S35-16-16	25	1	-16	25.4	68	60	54
S35-20-20	31	1 1/4	-20	31.8	70	60	54

S40 SteckO® adaptor

90° Swivel Female

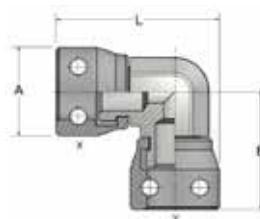

Part Number	Port Size				Y				L mm	A mm	B mm
	DN	Inch	Size	mm	DN	Inch	Size	mm			
S40-4-4	6	1/4	-4	6.4	6	1/4	-4	6.4	58	25	45
S40-6-6	10	3/8	-6	9.5	10	3/8	-6	9.5	63	32	48
S40-8-8	12	1/2	-8	12.7	12	1/2	-8	12.7	66	35	50
S40-12-12	19	3/4	-12	19.1	19	3/4	-12	19.1	72	45	53
S40-16-16	25	1	-16	25.4	25	1	-16	25.4	93	60	68
S40-20-20	31	1 1/4	-20	31.8	31	1 1/4	-20	31.8	99	60	70

S45 SteckO® adaptor

90° Fixed Female

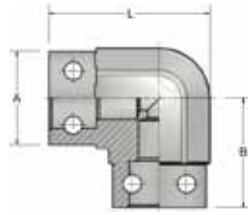

Part Number	Port Size				L mm	A mm	B mm	AF mm
	DN	Inch	Size	mm				
S45-4-4	6	1/4	-4	6.4	53	32	37	27
S45-6-6	10	3/8	-6	9.5	53	32	37	27
S45-8-8	12	1/2	-8	12.7	59	38	40	32
S45-12-12	19	3/4	-12	19.1	63	41	42	41
S45-16-16	25	1	-16	25.4	78	55	50	50
S45-20-20	31	1 1/4	-20	31.8	84	61	53	55
S45-24-24	38	1 1/2	-24	38.1	102	70	67	70
S45-32-32	51	2	-32	50.8	111	82	70	80
S45-40-40	63	2 1/2	-40	63.5	210	100	160	105
S45-48-48	76	3	-48	76.2	240	120	180	115

S50 SteckO® adaptor

Swivel Female Tee

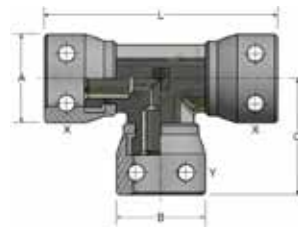

Part Number	Port Size				Y				L mm	A mm	B mm	C mm
	DN	Inch	Size	mm	DN	Inch	Size	mm				
S50-4-4-4	6	1/4	-4	6.4	6	1/4	-4	6.4	90	25	25	45
S50-6-6-6	10	3/8	-6	9.5	10	3/8	-6	9.5	96	32	32	48
S50-8-8-6	12	1/2	-8	12.7	10	3/8	-6	9.5	100	35	32	50
S50-8-8-8	12	1/2	-8	12.7	12	1/2	-8	12.7	100	35	35	50
S50-12-12-8	19	3/4	-12	19.1	12	1/2	-8	12.7	106	45	35	53
S50-12-12-12	19	3/4	-12	19.1	19	3/4	-12	19.1	106	45	45	53
S50-16-16-8	25	1	-16	25.4	12	1/2	-8	12.7	136	60	35	59
S50-16-16-12	25	1	-16	25.4	19	3/4	-12	19.1	136	60	45	59
S50-16-16-16	25	1	-16	25.4	25	1	-16	25.4	136	60	60	78
S50-20-20-12	31	1 1/4	-20	31.8	19	3/4	-12	19.1	140	60	45	62
S50-20-20-16	31	1 1/4	-20	31.8	25	1	-16	25.4	140	60	60	71
S50-20-20-20	31	1 1/4	-20	31.8	31	1 1/4	-20	31.8	140	60	60	70

S55 SteckO® adaptor

Swivel Female Tee

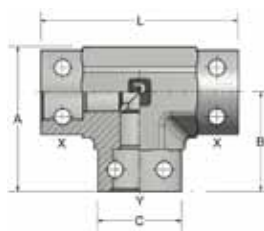

Part Number	Port Size				Y				L	A	B	C
	DN	Inch	Size	mm	DN	Inch	Size	mm				
S55-4-4-4	6	1/4	-4	6.4	6	1/4	-4	6.4	75	53	37	32
S55-6-6-6	10	3/8	-6	9.5	10	3/8	-6	9.5	73	53	37	32
S55-8-8-6	12	1/2	-8	12.7	10	3/8	-6	9.5	78	59	40	32
S55-8-8-8	12	1/2	-8	12.7	12	1/2	-8	12.7	78	59	40	38
S55-12-12-6	19	3/4	-12	19.1	10	3/8	-6	9.5	84	63	42	32
S55-12-12-8	19	3/4	-12	19.1	12	1/2	-8	12.7	84	63	42	35
S55-12-12-12	19	3/4	-12	19.1	19	3/4	-12	19.1	84	63	42	41
S55-16-16-6	25	1	-16	25.4	10	3/8	-6	9.5	100	78	50	32
S55-16-16-8	25	1	-16	25.4	12	1/2	-8	12.7	100	78	50	35
S55-16-16-12	25	1	-16	25.4	19	3/4	-12	19.1	100	78	50	45
S55-16-16-16	25	1	-16	25.4	25	1	-16	25.4	100	78	50	55
S55-20-20-6	31	1 1/4	-20	31.8	10	3/8	-6	9.5	107	84	53	32
S55-20-20-8	31	1 1/4	-20	31.8	12	1/2	-8	12.7	107	84	53	35
S55-20-20-12	31	1 1/4	-20	31.8	19	3/4	-12	19.1	107	84	53	45
S55-20-20-16	31	1 1/4	-20	31.8	25	1	-16	25.4	107	84	53	55
S55-20-20-20	31	1 1/4	-20	31.8	31	1 1/4	-20	31.8	107	84	53	61
S55-24-24-8	38	1 1/2	-24	38.1	12	1/2	-8	12.7	134	102	67	35
S55-24-24-12	38	1 1/2	-24	38.1	19	3/4	-12	19.1	134	102	67	45
S55-24-24-16	38	1 1/2	-24	38.1	25	1	-16	25.4	134	102	67	55
S55-24-24-20	38	1 1/2	-24	38.1	31	1 1/4	-20	31.8	134	102	67	60
S55-24-24-24	38	1 1/2	-24	38.1	38	1 1/2	-24	38.1	134	102	67	70
S55-32-32-20	51	2	-32	50.8	31	1 1/4	-20	31.8	146	111	70	60
S55-32-32-24	51	2	-32	50.8	38	1 1/2	-24	38.1	146	111	70	70
S55-32-32-32	51	2	-32	50.8	51	2	-32	50.8	140	111	70	82
S55-40-40-40	63	2 1/2	-40	63.5	63	2 1/2	-40	63.5	320	210	160	100
S55-40-40-32	63	2 1/2	-40	63.5	51	2	-32	50.8	320	190	145	90
S55-48-48-48	76	3	-48	76.2	76	3	-48	76.2	360	240	180	170
S55-48-48-32	76	3	-48	76.2	51	2	-32	50.8	360	220	175	90

S60 SteckO® adaptor

Cross - Fixed Demale

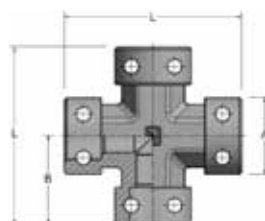

Part Number	Port Size				L	A	B
	DN	Inch	Size	mm			
S60-6-6-6-6	10	3/8	-6	9.5	75	38	32
S60-8-8-8-8	12	1/2	-8	12.7	80	40	38
S60-12-12-12-12	19	3/4	-12	19.1	80	40	41

S70 SteckO® adaptor
Straight Fixed Female

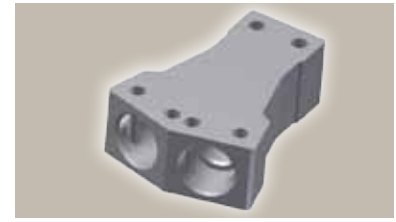
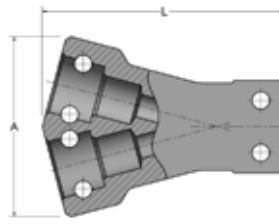

Part Number	Port Size				L mm	A mm
	DN	Inch	Size	mm		
S70-6-6-6	10	3/8	-6	9.5	83	65

S72 SteckO® adaptor
S-O Male - Swivel Female

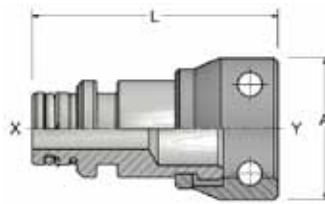

Part Number	Port Size				Y				L mm	A mm
	DN	Inch	Size	mm	DN	Inch	Size	mm		
S72-4-4	6	1/4	-4	6.4	6	1/4	-4	6.4	65	25
S72-6-4	6	1/4	-4	6.4	10	3/8	-6	9.5	65	32
S72-8-4	6	1/4	-4	6.4	12	1/2	-8	12.7	65	35
S72-4-6	10	3/8	-6	9.5	6	1/4	-4	6.4	60	25
S72-6-6	10	3/8	-6	9.5	10	3/8	-6	9.5	65	32
S72-8-6	10	3/8	-6	9.5	12	1/2	-8	12.7	65	35
S72-12-6	10	3/8	-6	9.5	19	3/4	-12	19.1	70	45
S72-4-8	12	1/2	-8	12.7	6	1/4	-4	6.4	60	25
S72-6-8	12	1/2	-8	12.7	10	3/8	-6	9.5	60	32
S72-8-8	12	1/2	-8	12.7	12	1/2	-8	12.7	60	35
S72-12-8	12	1/2	-8	12.7	19	3/4	-12	19.1	65	45
S72-6-12	19	3/4	-12	19.1	10	3/8	-6	9.5	60	32
S72-8-12	19	3/4	-12	19.1	12	1/2	-8	12.7	60	35
S72-12-12	19	3/4	-12	19.1	19	3/4	-12	19.1	70	45
S72-16-12	19	3/4	-12	19.1	25	1	-16	25.4	72	60
S72-20-12	19	3/4	-12	19.1	31	1 1/4	-20	31.8	72	60
S72-8-16	25	1	-16	25.4	12	1/2	-8	12.7	72	35
S72-12-16	25	1	-16	25.4	19	3/4	-12	19.1	72	45
S72-16-16	25	1	-16	25.4	25	1	-16	25.4	72	60
S72-20-16	25	1	-16	25.4	31	1 1/4	-20	31.8	78	60
S72-8-20	31	1 1/4	-20	31.8	12	1/2	-8	12.7	78	35
S72-12-20	31	1 1/4	-20	31.8	19	3/4	-12	19.1	78	45
S72-16-20	31	1 1/4	-20	31.8	25	1	-16	25.4	86	60
S72-20-20	31	1 1/4	-20	31.8	31	1 1/4	-20	31.8	78	60
S72-24-20	31	1 1/4	-20	31.8	38	1 1/2	-24	38.1	90	80
S72-16-24	38	1 1/2	-24	38.1	25	1	-16	25.4	90	60
S72-20-24	38	1 1/2	-24	38.1	31	1 1/4	-20	31.8	90	60
S72-16-32	51	2	-32	50.8	25	1	-16	25.4	90	60
S72-20-32	51	2	-32	50.8	31	1 1/4	-20	31.8	90	60
S72-24-32	51	2	-32	50.8	38	1 1/2	-24	38.1	90	80

S74 SteckO® adaptor

45° S-O Male - Swivel Female

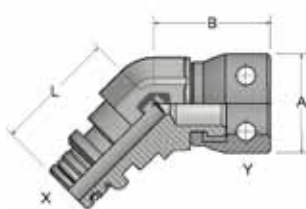

Part Number	Port Size				Y				L	A	B	A/F
	DN	Inch	Size	mm	DN	Inch	Size	mm				
S74-4-4	6	1/4	-4	6.4	6	1/4	-4	6.4	38	25	37	19
S74-6-6	10	3/8	-6	9.5	10	3/8	-6	9.5	38	32	37	23
S74-6-8	12	1/2	-8	12.7	10	3/8	-6	9.5	38	32	37	30
S74-8-8	12	1/2	-8	12.7	12	1/2	-8	12.7	38	35	37	30
S74-12-12	19	3/4	-12	19.1	19	3/4	-12	19.1	48	45	44	38
S74-16-16	25	1	-16	25.4	25	1	-16	25.4	50	60	52	50
S74-20-20	31	1 1/4	-20	31.8	31	1 1/4	-20	31.8	50	60	52	50
S74-24-24	38	1 1/2	-24	38.1	38	1 1/2	-24	38.1	70	80	67	70

S76 SteckO® adaptor

90° S-O Male - Swivel Female

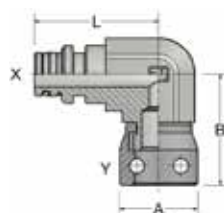

Part Number	Port Size				Y				L	A	B
	DN	Inch	Size	mm	DN	Inch	Size	mm			
S76-4-4	6	1/4	-4	6.4	6	1/4	-4	6.4	45	25	43
S76-4-6	10	3/8	-6	9.5	6	1/4	-4	6.4	46	25	45
S76-6-6	10	3/8	-6	9.5	10	3/8	-6	9.5	45	32	42
S76-8-6	10	3/8	-6	9.5	12	1/2	-8	12.7	50	35	50
S76-6-8	12	1/2	-8	12.7	10	3/8	-6	9.5	50	32	48
S76-8-8	12	1/2	-8	12.7	12	1/2	-8	12.7	50	35	45
S76-12-8	12	1/2	-8	12.7	19	3/4	-12	19.1	55	45	53
S76-8-12	19	3/4	-12	19.1	12	1/2	-8	12.7	54	35	52
S76-12-12	19	3/4	-12	19.1	19	3/4	-12	19.1	50	45	53
S76-16-12	19	3/4	-12	19.1	25	1	-16	25.4	62	60	68
S76-12-16	25	1	-16	25.4	19	3/4	-12	19.1	69	45	56
S76-16-16	25	1	-16	25.4	25	1	-16	25.4	65	60	66
S76-20-16	25	1	-16	25.4	31	1 1/4	-20	31.8	75	60	70
S76-16-20	31	1 1/4	-20	31.8	25	1	-16	25.4	73	60	68
S76-20-20	31	1 1/4	-20	31.8	31	1 1/4	-20	31.8	67	60	66
S76F-24-24	38	1 1/2	-24	38.1	38	1 1/2	-24	38.1	85	80	67

S77

SteckO® adaptor

S-O Male - Swivel Female Tee

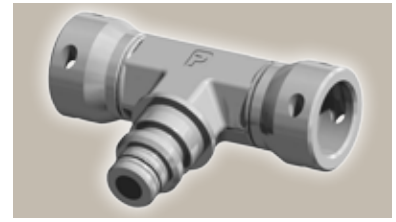
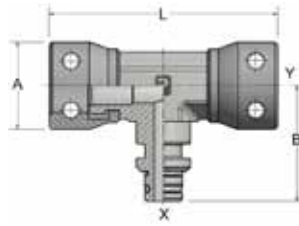

Part Number	Port Size				Y				L	A	B
	DN	Inch	Size	mm	DN	Inch	Size	mm	mm	mm	mm
S77-4-4-4	6	1/4	-4	6.4	6	1/4	-4	6.4	90	25	45
S77-6-6-6	10	3/8	-6	9.5	10	3/8	-6	9.5	96	32	48
S77-8-8-8	12	1/2	-8	12.7	12	1/2	-8	12.7	100	35	52
S77-12-12-12	19	3/4	-12	19.1	19	3/4	-12	19.1	106	45	56
S77-16-16-16	25	1	-16	25.4	25	1	-16	25.4	136	60	72
S77-20-20-20	31	1 1/4	-20	31.8	31	1 1/4	-20	31.8	140	60	76

S78

SteckO® adaptor

S-O Male - Swivel Female L

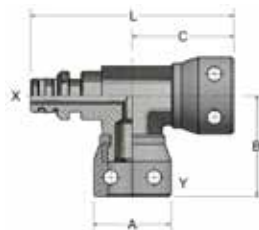

Part Number	Port Size				Y				L	A	B	C
	DN	Inch	Size	mm	DN	Inch	Size	mm	mm	mm	mm	mm
S78-4-4-4	6	1/4	-4	6.4	6	1/4	-4	6.4	90	25	45	45
S78-6-6-6	10	3/8	-6	9.5	10	3/8	-6	9.5	93	32	46	47
S78-8-8-8	12	1/2	-8	12.7	12	1/2	-8	12.7	102	35	52	50
S78-12-12-12	19	3/4	-12	19.1	19	3/4	-12	19.1	109	45	56	53
S78-16-16-16	25	1	-16	25.4	25	1	-16	25.4	140	60	72	68
S78-20-20-20	31	1 1/4	-20	31.8	31	1 1/4	-20	31.8	146	60	76	70
S78F-6-6-6	10	3/8	-6	9.5	10	3/8	-6	9.5	84	84	30	37

S80

SteckO® adaptor

Swivel Female - NPTF Male

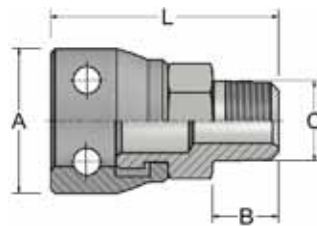

Part Number	Port Size				L	A	B	Port Thread NPTF	AF
	DN	Inch	Size	mm	mm	mm	mm	Inch	mm
S80-4-4	6	1/4	-4	6.4	51	25	15	1/4	19
S80-6-6	10	3/8	-6	9.5	51	32	15	3/8	22
S80-8-8	12	1/2	-8	12.7	58	35	19	1/2	27
S80-12-12	19	3/4	-12	19.1	60	45	19	3/4	36
S80-16-16	25	1	-16	25.4	81	60	24	1	46
S80-20-20	31	1 1/4	-20	31.8	82	60	25	1 1/4	50

S90 SteckO® adaptor

45° Swivel Female - NPTF Male

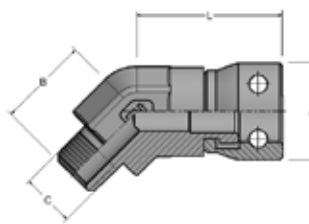

Part Number	Port Size				L mm	A mm	B mm	Port Thread NPTF	
	DN	Inch	Size	mm				Inch	
S90-4-4	6	1/4	-4	6.4	45	25	28	1/4	
S90-6-6	10	3/8	-6	9.5	48	32	30	3/8	
S90-8-8	12	1/2	-8	12.7	50	35	34	1/2	
S90-12-12	19	3/4	-12	19.1	53	45	38	3/4	
S90-16-16	25	1	-16	25.4	68	60	50	1	

S95 SteckO® adaptor

90° Swivel Female - NPTF Male

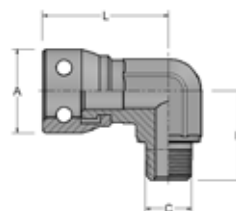

Part Number	Port Size				L mm	A mm	B mm	Port Thread NPTF	
	DN	Inch	Size	mm				Inch	
S95-4-4	6	1/4	-4	6.4	45	25	31	1/4	
S95-6-6	10	3/8	-6	9.5	48	32	34	3/8	
S95-8-8	12	1/2	-8	12.7	50	35	40	1/2	
S95-12-12	19	3/4	-12	19.1	53	45	44	3/4	
S95-16-16	25	1	-16	25.4	68	60	58	1	
S95-20-20	31	1 1/4	-20	31.8	67	60	67	1 1/4	

S114 SteckO® adaptor

S-O Swivel Female BSP Male



Part Number	Port Size				L mm	A mm	B mm	Port Thread NPTF		AF mm
	DN	Inch	Size	mm				Inch		
S114-4-4	6	1/4	-4	6.4	49	25	12	1/4		19
S114-6-6	10	3/8	-6	9.5	51	32	16	3/8		22
S114-8-8	12	1/2	-8	12.7	56	35	16	1/2		27
S114-8-16	12	1/2	-8	12.7	65	35	24	1		27
S114-12-12	19	3/4	-12	19.1	61	45	19	3/4		36
S114-16-12	25	1	-16	25.4	77	60	19	3/4		46
S114-16-16	25	1	-16	25.4	80	60	24	1		46
S114F-24-24*	38	1 1/2	-24	38.1	82	70	27	1 1/2		70
S114F-32-32*	51	2	-32	50.8	82	80	27	2		80

* F= Fixed Female

S115 SteckO® adaptor

Swivel Female - BSP Male

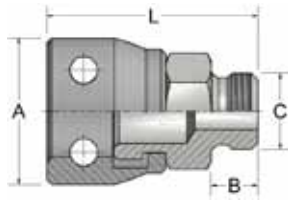

Part Number	Port Size				L mm	A mm	B mm	Port Thread BSP	
	DN	Inch	Size	mm				Inch	AF mm
S115-4-4	6	1/4	-4	6.4	46	25	9	1/4	19
S115-4-6	6	1/4	-4	6.4	46	25	10	3/8	22
S115-6-4	10	3/8	-6	9.5	47	32	9	1/4	22
S115-6-6	10	3/8	-6	9.5	47	32	10	3/8	22
S115-6-8	10	3/8	-6	9.5	52	32	13	1/2	27
S115-6-10	10	3/8	-6	9.5	53	32	13	5/8	30
S115-8-6	12	1/2	-8	12.7	50	35	10	3/8	27
S115-8-8	12	1/2	-8	12.7	53	35	13	1/2	27
S115-8-12	12	1/2	-8	12.7	56	35	14	3/4	32
S115-8-16	12	1/2	-8	12.7	58	35	17	1	41
S115-12-8	19	3/4	-12	19.1	56	45	13	1/2	36
S115-12-12	19	3/4	-12	19.1	56	45	14	3/4	36
S115-12-16	19	3/4	-12	19.1	56	45	17	1	45
S115-12-20	19	3/4	-12	19.1	59	45	19	1 1/4	50
S115-16-12	25	1	-16	25.4	72	60	14	3/4	46
S115-16-16	25	1	-16	25.4	73	60	17	1	46
S115-16-20	25	1	-16	25.4	79	60	19	1 1/4	50
S115-20-16	31	1 1/4	-20	31.8	76	60	17	1	50
S115-20-20	31	1 1/4	-20	31.8	76	60	19	1 1/4	50
S115-20-24	31	1 1/4	-20	31.8	81	60	20	1 1/2	55
S115F-24-24	38	1 1/2	-24	38.1	79	70	20	1 1/2	70
S115F-32-32	51	2	-32	50.8	80	80	23	2	80

S118 SteckO® adaptor

90° Swivel Female -
BSP Swivel Female

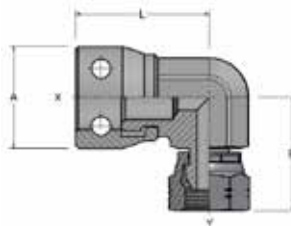

Part Number	Port Size				L mm	A mm	B mm	Port Thread BSP	
	DN	Inch	Size	mm				Inch	AF mm
S118-4-4	6	1/4	-4	6.4	31	25	43	1/4	
S118-6-6	10	3/8	-6	9.5	35	32	42	3/8	
S118-8-8	12	1/2	-8	12.7	40	35	45	1/2	
S118-12-12	19	3/4	-12	19.1	58	45	58	3/4	
S118-16-16	25	1	-16	25.4	67	60	65	1	
S118-20-20	31	1 1/4	-20	31.8	72	60	68	1 1/4	

S119 Stecko® adaptor

45° Swivel Female - BSP Swivel Female

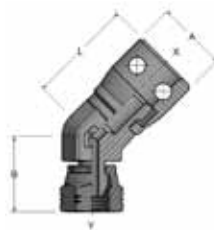

Part Number	Port Size				L mm	A mm	B mm	Port Thread BSP Inch
	DN	Inch	Size	mm				
S119-4-4	6	1/4	-4	6.4	37	25	27	1/4
S119-6-6	10	3/8	-6	9.5	37	32	29	3/8
S119-8-8	12	1/2	-8	12.7	37	35	33	1/2

S120 Stecko® adaptor

Double S-O Male

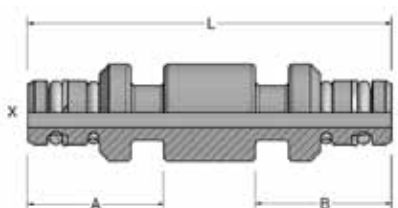

Part Number	Port Size				Y				L mm	A mm	B mm
	DN	Inch	Size	mm	DN	Inch	Size	mm			
S120-4-4	6	1/4	-4	6.4	6	1/4	-4	6.4	56	26	26
S120-4-6	10	3/8	-6	9.5	6	1/4	-4	6.4	56	26	26
S120-6-6	10	3/8	-6	9.5	10	3/8	-6	9.5	56	26	26
S120-4-8	12	1/2	-8	12.7	6	1/4	-4	6.4	56	26	26
S120-6-8	12	1/2	-8	12.7	10	3/8	-6	9.5	56	26	26
S120-8-8	12	1/2	-8	12.7	12	1/2	-8	12.7	56	26	26
S120-6-12	19	3/4	-12	19.1	10	3/8	-6	9.5	56	26	26
S120-8-12	19	3/4	-12	19.1	12	1/2	-8	12.7	56	26	26
S120-12-12	19	3/4	-12	19.1	19	3/4	-12	19.1	56	26	26
S120-8-16	25	1	-16	25.4	12	1/2	-8	12.7	61	32	26
S120-12-16	25	1	-16	25.4	19	3/4	-12	19.1	61	32	26
S120-16-16	25	1	-16	25.4	25	1	-16	25.4	66	32	32
S120-8-20	31	1 1/4	-20	31.8	12	1/2	-8	12.7	61	32	26
S120-12-20	31	1 1/4	-20	31.8	19	3/4	-12	19.1	61	32	26
S120-16-20	31	1 1/4	-20	31.8	25	1	-16	25.4	66	32	32
S120-20-20	31	1 1/4	-20	31.8	31	1 1/4	-20	31.8	66	32	32
S120-12-24	38	1 1/2	-24	38.1	19	3/4	-12	19.1	68	36	26
S120-16-24	38	1 1/2	-24	38.1	25	1	-16	25.4	74	36	32
S120-20-24	38	1 1/2	-24	38.1	31	1 1/4	-20	31.8	74	36	32
S120-24-24	38	1 1/2	-24	38.1	38	1 1/2	-24	38.1	78	36	36
S120-12-32	51	2	-32	50.8	19	3/4	-12	19.1	74	36	26
S120-16-32	51	2	-32	50.8	25	1	-16	25.4	74	36	32
S120-20-32	51	2	-32	50.8	31	1 1/4	-20	31.8	74	36	32
S120-24-32	51	2	-32	50.8	38	1 1/2	-24	38.1	78	36	36
S120-32-32	51	2	-32	50.8	51	2	-32	50.8	78	36	36
S120-40-40	63	2 1/2	-40	63	63	2 1/2	-40	63.5	140	65	65
S120-48-48	76	3	-48	76.2	76	3	-48	76.2	150	70	70

S125 SteckO® adaptor

S-O Male - NPTF Male

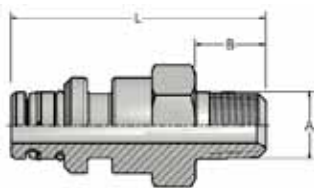

Part Number	Port Size				L mm	Port Thread NPTF Inch	B mm	A/F mm
	DN	Inch	Size	mm				
S125-4-4	6	1/4	-4	6.4	53	1/4	15	19
S125-6-6	10	3/8	-6	9.5	53	3/8	15	22
S125-8-8	12	1/2	-8	12.7	60	1/2	19	27
S125-12-12	19	3/4	-12	19.1	64	3/4	19	32
S125-16-16	25	1	-16	25.4	79	1	24	41
S125-20-20	31	1 1/4	-20	31.8	79	1 1/4	25	50
S125-24-24	38	1 1/2	-24	38.1	80	1 1/2	26	60
S125-32-32	51	2	-32	50.8	80	2	26	70

S140 SteckO® adaptor

S-O Male - UNF Male O-Ring

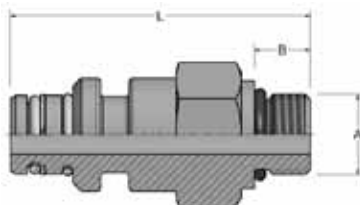

Part Number	Port Size				L mm	Port Thread UNF Inch	B mm	A/F mm
	DN	Inch	Size	mm				
S140-4-4	6	1/4	-4	6.4	52	7/16 x 20	13	19
S140-6-6	10	3/8	-6	9.5	53	9/16 x 18	13	22
S140-8-8	12	1/2	-8	12.7	56	3/4 x 16	15	27
S140-12-12	19	3/4	-12	19.1	60	1 1/16 x 12	19	36
S140-16-16	25	1	-16	25.4	74	1 5/16 x 12	20	41
S140-20-20	31	1 1/4	-20	31.8	79	1 5/8 x 12	20	50

S155 SteckO® adaptor

S-O Male - BSP Male

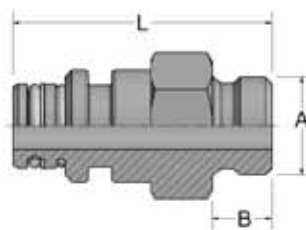

Part Number	Port Size				L mm	Port Thread BSP Inch	B mm	A/F mm
	DN	Inch	Size	mm				
S155-4-4	6	1/4	-4	6.4	51	1/4	9	19
S155-4-6	6	1/4	-4	6.4	51	3/8	10	22
S155-6-4	10	3/8	-6	9.5	50	1/4	9	22
S155-6-6	10	3/8	-6	9.5	50	3/8	10	22
S155-6-8	10	3/8	-6	9.5	50	1/2	13	27
S155-8-6	12	1/2	-8	12.7	50	3/8	10	27
S155-8-8	12	1/2	-8	12.7	55	1/2	13	27
S155-8-12	12	1/2	-8	12.7	58	3/4	14	32
S155-12-10	19	3/4	-12	19.1	58	5/8	13	32
S155-12-12	19	3/4	-12	19.1	58	3/4	14	32
S155-12-16	19	3/4	-12	19.1	62	1	17	41
S155-16-12	25	1	-16	25.4	72	3/4	14	16
S155-16-16	25	1	-16	25.4	72	1	17	46
S155-16-20	25	1	-16	25.4	79	1 1/4	19	50
S155-20-20	31	1 1/4	-20	31.8	79	1 1/4	19	50
S155-20-24	31	1 1/4	-20	31.8	79	1 1/2	20	55
S155-24-24	38	1 1/2	-24	38.1	82	1 1/2	23	65
S155-32-32	51	2	-32	50.8	82	2	23	70

S160 SteckO®

Female End Cap

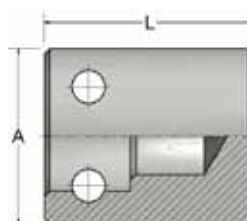

Part Number	Port Size				L mm	A mm
	DN	Inch	Size	mm		
S160-4	6	1/4	-4	6.4	35	25
S160-6	10	3/8	-6	9.5	38	30
S160-8	12	1/2	-8	12.7	38	35
S160-12	19	3/4	-12	19.1	40	40
S160-16	25	1	-16	25.4	50	55
S160-20	31	1 1/4	-20	31.8	50	60
S160-24	38	1 1/2	-24	38.1	80	70
S160-32	51	2	-32	50.8	80	80
S160-40	63	2 1/2	-40	63.5	120	100
S160-48	76	3	-48	76.2	140	120

S165 SteckO®

S-O Male Plug

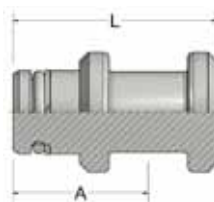

Part Number	Port Size				L mm	A mm
	DN	Inch	Size	mm		
S165-4	6	1/4	-4	6.4	34	26
S165-6	10	3/8	-6	9.5	34	26
S165-8	12	1/2	-8	12.7	34	26
S165-12	19	3/4	-12	19.1	34	26
S165-16	25	1	-16	25.4	41	32
S165-20	31	1 1/4	-20	31.8	41	32
S165-24	38	1 1/2	-24	38.1	44	36
S165-32	51	2	-32	50.8	44	36
S165-40	63	2 1/2	-40	63.5	80	50
S165-48	76	3	-48	76.2	110	70

S170 SteckO®

Staple



Part Number	Port Size				L mm	A mm
	DN	Inch	Size	mm		
S170-4	6	1/4	-4	6.4	38	7.5
S170-6	10	3/8	-6	9.5	42	12.5
S170-8	12	1/2	-8	12.7	48	16.5
S170-12	19	3/4	-12	19.1	55	21.0
S170-16	25	1	-16	25.4	74	27.5
S170-20	31	1 1/4	-20	31.8	83	34.5
S170-24	38	1 1/2	-24	38.1	105	44.0
S170-32	51	2	-32	50.8	125	58.0

S170ZN SteckO®

Staple

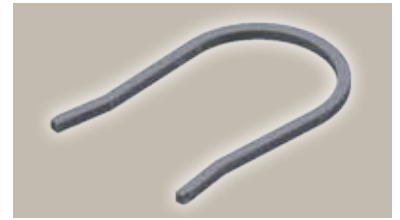

Part Number	Port Size				L mm	A mm
	DN	Inch	Size	mm		
S170-4-ZN	6	1/4	-4	6.4	38	7.5
S170-6-ZN	10	3/8	-6	9.5	42	12.5
S170-8-ZN	12	1/2	-8	12.7	48	16.5
S170-12-ZN	19	3/4	-12	19.1	55	21.0
S170-16-ZN	25	1	-16	25.4	74	27.5
S170-20-ZN	31	1 1/4	-20	31.8	83	34.5
S170-24-ZN	38	1 1/2	-24	38.1	105	44.0
S170-32-ZN	51	2	-32	50.8	125	58.0

S175 SteckO®

Staple



Part Number	Port Size				L mm	A mm
	DN	Inch	Size	mm		
S175-4	6	1/4	-4	6.4	40	8.0
S175-6	10	3/8	-6	9.5	42	13.0
S175-8	12	1/2	-8	12.7	53	17.0
S175-12	19	3/4	-12	19.1	60	22.0
S175-16	25	1	-16	25.4	77	29.0
S175-20	31	1 1/4	-20	31.8	85	36.0
S175-24	38	1 1/2	-24	38.1	89	43.0
S175-32	51	2	-32	50.8	445	55.5
S175-40	63	2 1/2	-40	63.5	100	71.0
S175-48	76	3	-48	76.2	120	78.0

S175D SteckO®

Staple



Part Number	Port Size				L mm	A mm
	DN	Inch	Size	mm		
S175D-4	6	1/4	-4	6.4	40	8
S175D-6	10	3/8	-6	9.5	44	12.5
S175D-8	12	1/2	-8	12.7	53	16.5
S175D-12	19	3/4	-12	19.1	63	22
S175D-16	25	1	-16	25.4	79	28
S175D-20	31	1 1/4	-20	31.8	87	36
S175D-24	38	1 1/2	-24	38.1	88	47
S175D-32	51	2	-32	50.8	110	55

S180

SteckO®

O-Ring



Part Number	Port Size			
	DN	Inch	Size	mm
S180-4	6	1/4	-4	6.4
S180-6	10	3/8	-6	9.5
S180-8	12	1/2	-8	12.7
S180-12	19	3/4	-12	19.1
S180-16	25	1	-16	25.4
S180-20	31	1 1/4	-20	31.8
S180-24	38	1 1/2	-24	38.1
S180-32	51	2	-32	50.8
S180-40	63	2 1/2	-40	63.5
S180-48	76	3	-48	76.2

S195

SteckO®

Backup Ring



Part Number	Port Size			
	DN	Inch	Size	mm
S195-4	6	1/4	-4	6.4
S195-6	10	3/8	-6	9.5
S195-8	12	1/2	-8	12.7
S195-12	19	3/4	-12	19.1
S195-16	25	1	-16	25.4
S195-20	31	1 1/4	-20	31.8
S195-24	38	1 1/2	-24	38.1
S195-32	51	2	-32	50.8

S200

SteckO®

Plastic cap



Part Number	Port Size			
	DN	Inch	Size	mm
S200-4	6	1/4	-4	6.4
S200-6	10	3/8	-6	9.5
S200-8	12	1/2	-8	12.7
S200-12	19	3/4	-12	19.1
S200-16	25	1	-16	25.4
S200-20	31	1 1/4	-20	31.8
S200-24	38	1 1/2	-24	38.1
S200-32	51	2	-32	50.8

SS30 Super SteckO® adaptor

Straight SS-O Female

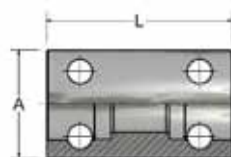

Part Number	Port Size				L mm	A mm
	DN	Inch	Size	mm		
SS30-8-8	12	1/2	-8	12.7	70	38
SS30-12-12	19	3/4	-12	19.1	90	45
SS30-16-16	25	1	-16	25.4	110	60
SS30-20-20	31	1 1/4	-20	31.8	110	70
SS30-24-24	38	1 1/2	-24	38.1	115	82
SS30-32-32	51	2	-32	50.8	120	95

SS40 Super SteckO® adaptor

90° SS-O-Female

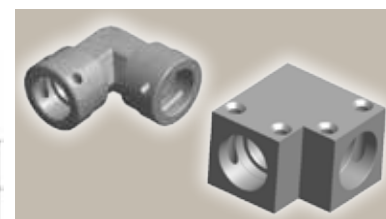
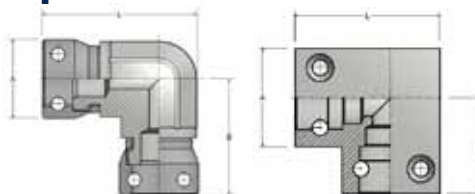

Part Number	Port Size				L mm	A mm	B mm
	DN	Inch	Size	mm			
SS40-8-8	12	1/2	-8	12.7	72	38	52
SS40-12-12	19	3/4	-12	19.1	82	45	62
SS40-16-16	25	1	-16	25.4	110	65	75
SS45-20-20	31	1 1/4	-20	31.8	112	70	78
SS45-24-24	38	1 1/2	-24	38.1	125	82	83
SS45-32-32	51	2	-32	50.8	136	95	88

SS50 Super SteckO® adaptor

SS-O-Female Tee

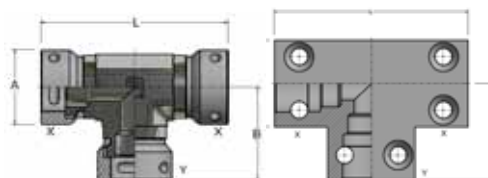

Part Number	Port Size				Y				L mm	A mm	B mm
	DN	Inch	Size	mm	DN	Inch	Size	mm			
SS50-16-16-16	25	1	-16	25.4	25	1	-16	25.4	164	60	75
SS55-20-20-20	31	1 1/4	-20	31.8	31	1 1/4	-20	31.8	155	70	78
SS55-24-24-24	38	1 1/2	-24	38.1	38	1 1/2	-24	38.1	106	82	78
SS55-32-32-32	51	2	-32	50.8	51	2	-32	50.8	176	95	89

SS72 Super SteckO® adaptor

SS-O Male - S-O - Female

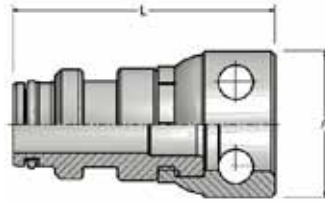

Part Number	Port Size				Y				L	A
	DN	Inch	Size	mm	DN	Inch	Size	mm	mm	mm
SS72-S8-12	19	3/4	-12	19.1	12	1/2	-8	12.8	75	35
SS72-S12-16	25	1	-16	25.4	19	3/4	-12	19.1	79	35
SS72-S8-20	31	1 1/4	-20	31.8	12	1/2	-8	12.7	81	35
SS72-S12-20	31	1 1/4	-20	31.8	19	3/4	-12	19.1	81	45
SS72-S16-20	31	1 1/4	-20	31.8	25	1	-16	25.4	98	55
SS72-S20-20	31	1 1/4	-20	31.8	31	1 1/4	-20	31.8	100	60
SS72-S16-24	38	1 1/2	-24	38.1	25	1	-16	25.4	110	55
SS72-S20-24	38	1 1/2	-24	38.1	31	1 1/4	-20	31.8	110	60
SS72-S16-32	51	2	-32	50.8	25	1	-16	25.4	89	60
SS72-S20-32	51	2	-32	50.8	31	1 1/4	-20	31.8	89	60

SS76 Super SteckO® adaptor

90° SS-O - Male - Felame

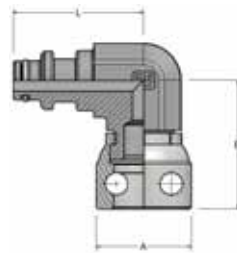

Part Number	Port Size				L	A	B
	DN	Inch	Size	mm	mm	mm	mm
SS76-8-8	12	1/2	-8	12.7	60	38	50
SS76-12-12	19	3/4	-12	19.1	65	45	64
SS76-16-16	25	1	-16	25.4	82	60	90
SS76-20-20	31	1 1/4	-20	31.8	100	70	78
SS76-24-24	38	1 1/2	-24	38.1	114	82	83
SS76-32-32	51	2	-32	50.8	130	95	88

SS85 Super SteckO® adaptor

SS-O - Female - NPTF Male

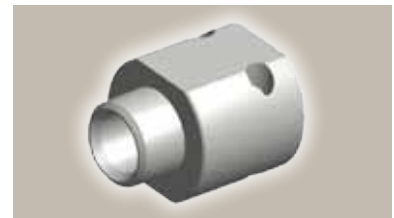
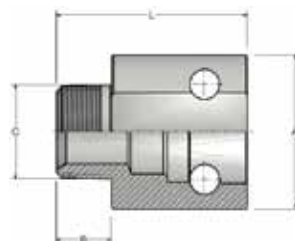

Part Number	Port Size				L	A	B	Port Thread NPTF
	DN	Inch	Size	mm	mm	mm	mm	Inch
SS85-20-20	31	1 1/4	-20	31.8	90	70	19	1 1/4
SS85-24-24	38	1 1/2	-24	38.1	100	82	20	1 1/2
SS85-32-32	51	2	-32	50.8	112	95	20	2

SS115 Super SteckO® adaptor

SS-O Female - BSP Male

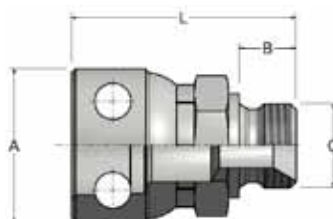

Part Number	Port Size				L mm	Port Thread A mm	B mm	Port Thread BSP Inch	AF mm
	DN	Inch	Size	mm					
SS115-8-8	12	1/2	-8	12.7	65	38	13	1/2	27
SS115-12-12	19	3/4	-12	19.1	68	45	14	3/4	36
SS115-16-16	25	1	-16	25.4	90	60	17	1	50
SS115-20-20	31	1 1/4	-20	31.8	80	60	19	1 1/4	60
SS115-24-24	38	1 1/2	-24	38.1	100	82	20	1 1/2	70
SS115F-32-32*	51	2	-32	50.8	112	95	20	2	80

* F= Fixed Female

SS120S Super SteckO® adaptor

SS-O - S-O Double Male

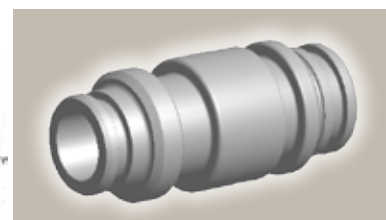
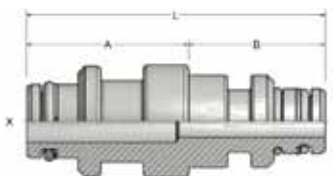

Part Number	Port Size				Y				L mm	A mm	B mm
	DN	Inch	Size	mm	DN	Inch	Size	mm			
SS120-S6-8	12	1/2	-8	12.7	10	3/8	-6	9.5	61	32	26
SS120-S8-12	19	3/4	-12	19.1	12	1/2	-8	12.7	66	36	26
SS120-S12-16	25	1	-16	25.4	19	3/4	-12	19.1	81	50	26
SS120-S16-20	31	1 1/4	-20	31.8	25	1	-16	25.4	88	52	32
SS120-S20-24	38	1 1/2	-24	38.1	31	1 1/4	-20	31.8	93	58	32

SS120 Super SteckO® adaptor

Double SS-O Male

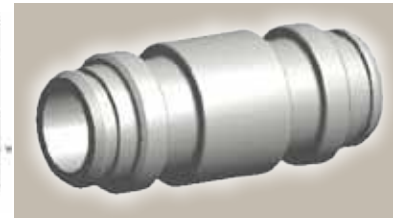
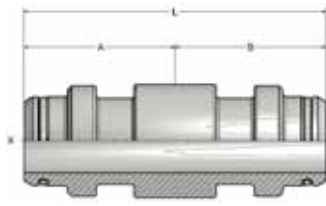

Part Number	Port Size				Y				L mm	A mm	B mm
	DN	Inch	Size	mm	DN	Inch	Size	mm			
SS120-8-8	12	1/2	-8	12.7	12	1/2	-8	12.7	66	32	32
SS120-12-12	19	3/4	-12	19.1	19	3/4	-12	19.1	75	36	36
SS120-8-12	19	3/4	-12	19.1	12	1/2	-8	12.7	70	36	32
SS120-16-16	25	1	-16	25.4	25	1	-16	25.4	105	50	50
SS120-12-16	25	1	-16	25.4	19	3/4	-12	19.1	90	50	36
SS120-20-20	31	1 1/4	-20	31.8	31	1 1/4	-20	31.8	110	52	52
SS120-16-20	31	1 1/4	-20	31.8	25	1	-16	25.4	110	52	50
SS120-24-24	38	1 1/2	-24	38.1	38	1 1/2	-24	38.1	120	58	58
SS120-20-24	38	1 1/2	-24	38.1	31	1 1/4	-20	31.8	120	58	52
SS120-32-32	51	2	-32	50.8	51	2	-32	50.8	125	60	60
SS120-20-32	51	2	-32	50.8	31	1 1/4	-20	31.8	125	60	52
SS120-24-32	51	2	-32	50.8	38	1 1/2	-24	38.1	125	60	58

SS125 Super SteckO® adaptor

SS-O - Male - NPTF Male

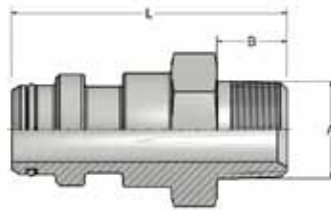

Part Number	Port Size				L mm	Port Thread NPTF Inch	B mm	A/F mm
	DN	Inch	Size	mm				
SS125-12-12	19	3/4	-12	19.1	70	3/4	19	32
SS125-16-16	25	1	-16	25.4	95	1	24	46
SS125-20-20	31	1 1/4	-20	31.8	96	1 1/4	25	50
SS125-24-24	38	1 1/2	-24	38.1	102	1 1/2	26	60
SS125-32-32	51	2	-32	50.8	105	2	26	70

SS155 Super SteckO® adaptor

SS-O - Male - BSP Male

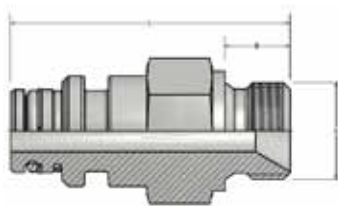

Part Number	Port Size				L mm	Port Thread BSP Inch	B mm	A/F mm
	DN	Inch	Size	mm				
SS155-8-8	12	1/2	-8	12.7	60	1/2	13	27
SS155-12-12	19	3/4	-12	19.1	68	3/4	14	32
SS155-16-16	25	1	-16	25.4	87	1	17	46
SS155-20-20	31	1 1/4	-20	31.8	90	1 1/4	19	50
SS155-24-24	38	1 1/2	-24	38.1	98	1 1/2	23	65
SS155-32-32	51	2	-32	50.8	105	2	23	70

SS160 Super SteckO®

End cap

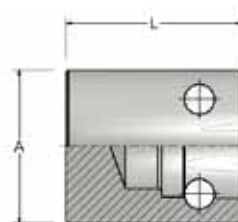

Part Number	Port Size				L mm	A mm
	DN	Inch	Size	mm		
SS160-8	12	1/2	-8	12.7	70	38
SS160-12	19	3/4	-12	19.1	75	45
SS160-16	25	1	-16	25.4	85	60
SS160-20	31	1 1/4	-20	31.8	90	70
SS160-24	38	1 1/2	-24	38.1	100	82
SS160-32	51	2	-32	50.8	100	95
SS160-40	63	2 1/2	-40	63.5	110	125
SS160-48	76	3	-48	76.2	120	145

SS165 Super SteckO®

Male Plug

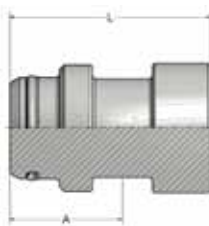

Part Number	Port Size				L mm	A mm
	DN	Inch	Size	mm		
SS165-8	12	1/2	-8	12.7	40	32
SS165-12	19	3/4	-12	19.1	45	36
SS165-16	25	1	-16	25.4	61	50
SS165-20	31	1 1/4	-20	31.8	64	52
SS165-24	38	1 1/2	-24	38.1	70	60
SS165-32	51	2	-32	50.8	70	60
SS165-40	63	2 1/2	-40	63.5	100	75
SS165-48	76	3	-48	76.2	105	93

SS175D Super SteckO®

Staple



Part Number	Port Size				L mm	A mm
	DN	Inch	Size	mm		
SS175D-8	12	1/2	-8	12.7	53	29
SS175D-12	19	3/4	-12	19.1	60	33
SS175D-16	25	1	-16	25.4	76	44
SS175D-20	31	1 1/4	-20	31.8	86	51
SS175D-24	38	1 1/2	-24	38.1	101	62
SS175D-32	51	2	-32	50.8	98	72

SS175 Super SteckO®

Staple



Part Number	Port Size				L mm	A mm
	DN	Inch	Size	mm		
SS175-40	63	2 1/2	-40	63.5	92	69
SS175-48	76	3	-48	76.2	133	84,5

SS180 Super SteckO®

O-Ring



Part Number	Port Size				Inner Diameter	Section
	DN	Inch	Size	mm		
SS180-8	12	1/2	-8	12.7	11	2.5
SS180-12	19	3/4	-12	19.1	17	2.5
S180-16*	25	1	-16	25.4	25	2.5
S180-20*	31	1 1/4	-20	31.8	33	2.5
SS180-24	38	1 1/2	-24	38.1	37	3.0
SS180-32	51	2	-32	50.8	43	3.0
SS180-40	63	2 1/2	-40	63.5	59	3.0
SS180-48	76	3	-48	76.2	75	3.5

*) interchangeable with SteckO O-ring

SS195 Super SteckO®

Backup Ring

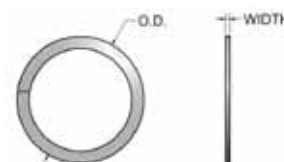





Part Number	Port Size				Inner Diameter	Section
	DN	Inch	Size	mm		
SS195-8	12	1/2	-8	12.7	12	0,8
SS195-12	19	3/4	-12	19.1	18	0,8
S195-16*	25	1	-16	25.4	31	0,8
S195-20*	31	1 1/4	-20	31.8	34	0,8
SS195-24	38	1 1/2	-24	38.1	39	1,5
SS195-32	51	2	-32	50.8	45	1,5
SS195-40	63	2 1/2	-40	63.5	60,2	2,4
SS195-48	76	3	-48	76.2	76	3

*) interchangeable with SteckO Back up washer

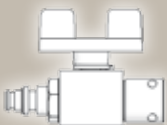
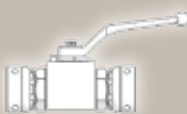
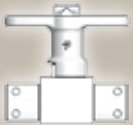
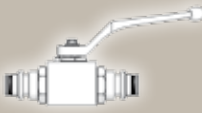
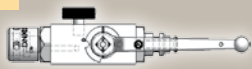
SteckO®

Page E-1 – E-6

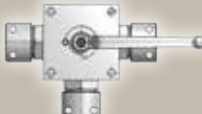
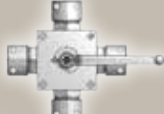
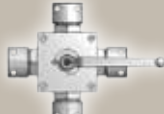
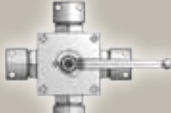
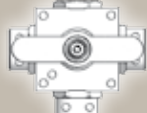
<p>CMV10 E-1</p>  <p>SteckO® Ball Valve Stecko Male – Female</p>	<p>CMV11 E-1</p>  <p>SteckO® Ball Valve Stecko Male – Fixed Female</p>	<p>CMV12 E-2</p>  <p>SteckO® Block Ball Valve Stecko Female – Female</p>	<p>CMV13 E-2</p>  <p>SteckO® Block Ball Valve Stecko Fixed Female</p>
<p>CMV14 E-3</p>  <p>SteckO® Block Ball Valve Stecko Male</p>	<p>CMV15 E-3</p>  <p>SteckO® Block Bleed Ball Valve Stecko Male – Female</p>	<p>CMV19 E-4</p>  <p>SteckO® Block Ball Valve Stecko Female Tee »T«</p>	<p>CMV20 E-4</p>  <p>SteckO® Block Ball Valve Stecko Female Tee »L«</p>
<p>CMV22 E-4</p>  <p>SteckO® Block Ball Valve Stecko Female Tee</p>	<p>CMV23 E-5</p>  <p>SteckO® Block Ball Valve Stecko Female Tee</p>	<p>CMV24 E-5</p>  <p>SteckO® Block Ball Valve Stecko Female Cross »T«</p>	<p>CMV25 E-5</p>  <p>SteckO® Block Ball Valve Stecko Female Cross »L«</p>
<p>CMV26 E-6</p>  <p>SteckO® Block Ball Valve Stecko Female Cross »X«</p>	<p>CMV27 E-6</p>  <p>SteckO® Block Ball Valve Stecko Female Cross »L« Compact</p>		

SuperSteckO®

Page E-7 – E-8

CMV30
E-7



Super SteckO® Block Ball Valve
Super SteckO Male – Female

CMV31
E-7

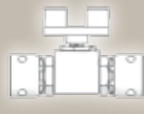

Super SteckO® Block Ball Valve
Super SteckO Female

CMV32
E-7

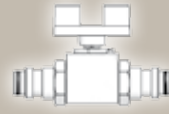

Super SteckO® Block Ball Valve
Super SteckO Male

CMV40
E-8

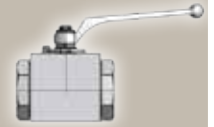

Block Ball Valve
BSP Female

CMV10 Stecko® Ball Valve

Stecko Male – Female

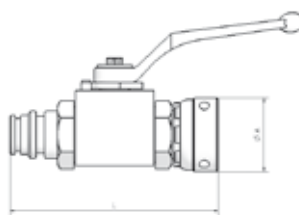

Part Number	Port Size				Pressure Rating		L	A
	DN	Inch	Size	mm	max. working pressure			
					MPa	psi	mm	mm
CMV10-04-1	6	1/4	-4	6.4	50.0	7250	1080	25
CMV10-06-1	10	3/8	-6	9.5	50.0	7250	108	32
CMV10-08-1	12	1/2	-8	12.7	50.0	7250	110	35
CMV10-12-1	19	3/4	-12	19.1	35.0	5000	134	45
CMV10-16-1	25	1	-16	25.4	35.0	5000	163	60
CMV10-20-1	31	1 1/4	-20	31.8	25.0	3600	163	60
CMV10-24-1	38	1 1/2	-24	38.1	16.0	2325	190	70
CMV10-32-1	51	2	-32	50.8	16.0	2325	211	82
CMV10-40-1	63	2 1/2	-40	63.5	3.5	500	350	100
CMV10-48-1	76	3	-48	76.2	3.5	500	400	120

CMV11 Stecko® Ball Valve

Stecko Male – Fixed Female

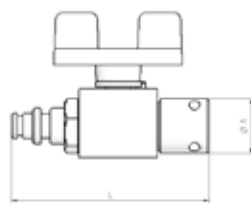

Part Number	Port Size				Pressure Rating		L	A
	DN	Inch	Size	mm	max. working pressure			
					MPa	psi	mm	mm
CMV11-06-4	10	3/8	-6	9.5	50.0	7250	104	30
CMV11-08-4	12	1/2	-8	12.7	50.0	7250	110	35

CMV12 Stecko® Block Ball Valve

Stecko Female – Female

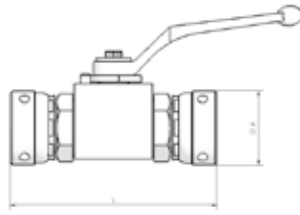

Part Number	Port Size				Pressure Rating		L	A
	DN	Inch	Size	mm	max. working pressure	max. working pressure		
					MPa	psi	mm	mm
CMV12-04-1	6	1/4	-4	6.4	50.0	7250	110	25
CMV12-06-1	10	3/8	-6	9.5	50.0	7250	110	32
CMV12-08-1	12	1/2	-8	12.7	50.0	7250	112	35
CMV12-12-1	19	3/4	-12	19.1	35.0	5000	135	45
CMV12-16-1	25	1	-16	25.4	35.0	5000	164	60
CMV12-20-1	31	1 1/4	-20	31.8	25.0	3600	164	60
CMV12-24-1	38	1 1/2	-24	38.1	16.0	2325	190	70
CMV12-32-1	51	2	-32	50.8	16.0	2325	211	82
CMV12-40-1	63	2 1/2	-40	63.5	3.5	500	360	100
CMV12-48-1	76	3	-48	76.2	3.5	500	400	120

CMV13 Stecko® Block Ball Valve

Stecko Fixed Female

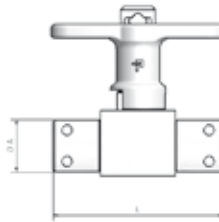

Part Number	Port Size				Pressure Rating		L	A
	DN	Inch	Size	mm	max. working pressure	max. working pressure		
					MPa	psi	mm	mm
CMV13-06-5	10	3/8	-6	9.5	50.0	7250	93	30
CMV13-08-5	12	1/2	-8	12.7	50.0	7250	106	35

CMV14 Stecko® Block Ball Valve

Stecko Male

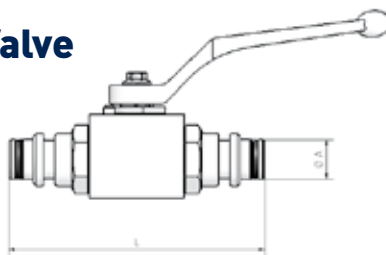

Part Number	Port Size				Pressure Rating		L	A
	DN	Inch	Size	mm	max. working pressure			
					MPa	psi	mm	mm
CMV14-04-1	6	1/4	-4	6.4	50.0	7250	115	15
CMV14-06-1	10	3/8	-6	9.5	50.0	7250	115	15
CMV14-08-1	12	1/2	-8	12.7	50.0	7250	115	15
CMV14-12-1	19	3/4	-12	19.1	35.0	5000	134	21
CMV14-16-1	25	1	-16	25.4	35.0	5000	162	20
CMV14-20-1	31	1 1/4	-20	31.8	25.0	3600	162	20
CMV14-24-1	38	1 1/2	-24	38.1	16.0	2325	175	41
CMV14-32-1	51	2	-32	50.8	16.0	2325	200	46

CMV15 Stecko® Block Bleed Ball Valve

Stecko Male – Female

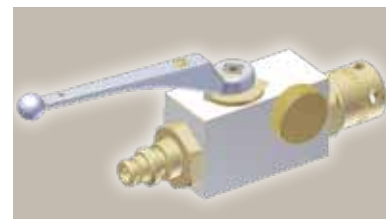
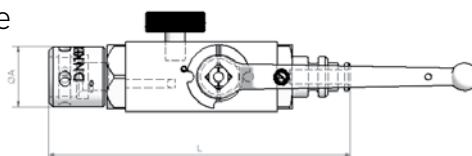

Part Number	Port Size				Pressure Rating		L	A
	DN	Inch	Size	mm	max. working pressure			
					MPa	psi	mm	mm
CMV15-06-1	10	3/8	-6	9.5	50.0	7250	150	32
CMV15-08-1	12	1/2	-8	12.7	50.0	7250	150	35

CMV19 Stecko® Block Ball Valve

Stecko Female Tee »T«

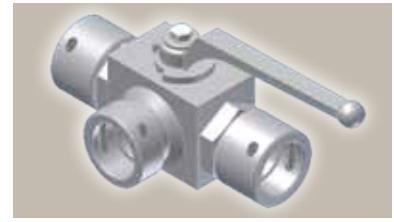
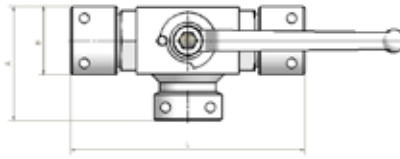

Part Number	Port Size				Pressure Rating		L	A	B
	DN	Inch	Size	mm	max. working pressure	MPa			
CMV19-06-1	10	3/8	-6	9.5	40.0	5800	143	65	35
CMV19-08-1	12	1/2	-8	12.7	40.0	5800	147	65	35
CMV19-12-1	19	3/4	-12	19.1	25.0	3600	141	70	40
CMV19-16-1	25	1	-16	25.4	16.0	2325	159	161	55

CMV20 Stecko® Block Ball Valve

Stecko Female Tee »L«

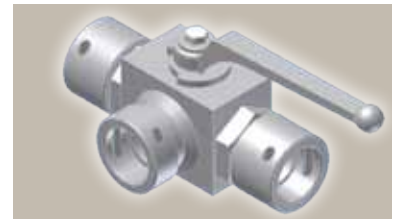
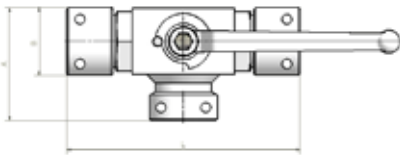

Part Number	Port Size				Pressure Rating		L	A	B
	DN	Inch	Size	mm	max. working pressure	MPa			
CMV20-06-1	10	3/8	-6	9.5	40.0	5800	143	65	35
CMV20-08-1	12	1/2	-8	12.7	40.0	5800	147	65	35
CMV20-12-1	19	3/4	-12	19.1	25.0	3600	141	70	40
CMV20-16-1	25	1	-16	25.4	16.0	2325	159	161	55

CMV22 Stecko® Block Ball Valve

Stecko Female Tee

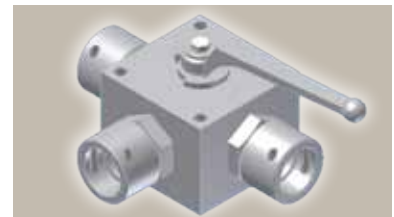
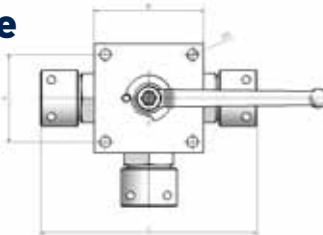

Part Number	Port Size				Pressure Rating		L	A	B	D
	DN	Inch	Size	mm	max. working pressure	MPa				
CMV22-06-1	10	3/8	-6	9.5	40.0	5800	150	65	80	6.5
CMV22-08-1	12	1/2	-8	12.7	40.0	5800	150	65	80	6.5
CMV22-12-1	19	3/4	-12	19.1	31.5	4500	170	80	100	9.0
CMV22-16-1	25	1	-16	25.4	25.0	3600	190	85	110	9.0

CMV23 Stecko® Block Ball Valve

Stecko Female Tee

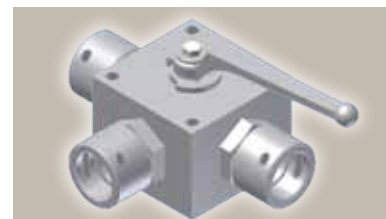
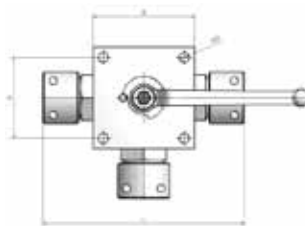

Part Number	Port Size				Pressure Rating max. working pressure		L mm	A mm	B mm	D mm
	DN	Inch	Size	mm	MPa	psi				
CMV23-06-1	10	3/8	-6	9.5	40.0	5800	150	65	80	6.5
CMV23-08-1	12	1/2	-8	12.7	40.0	5800	150	65	80	6.5
CMV23-12-1	19	3/4	-12	19.1	31.5	4500	170	80	100	9.0
CMV23-16-1	25	1	-16	25.4	25.0	3600	190	85	110	9.0

CMV24 Stecko® Block Ball Valve

Stecko Female Cross »T«

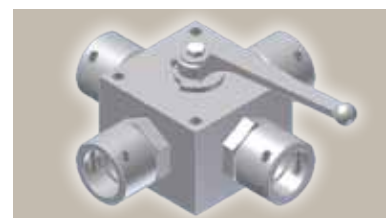
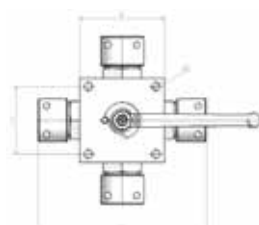

Part Number	Port Size				Pressure Rating max. working pressure		L mm	A mm	B mm	D mm
	DN	Inch	Size	mm	MPa	psi				
CMV24-06-1	10	3/8	-6	9.5	40.0	5800	150	65	80	6.5
CMV24-08-1	12	1/2	-8	12.7	40.0	5800	150	65	80	6.5
CMV24-12-1	19	3/4	-12	19.1	31.5	4500	170	80	100	9.0
CMV24-16-1	25	1	-16	25.4	25.0	3600	190	85	110	9.0

CMV25 Stecko® Block Ball Valve

Stecko Female Cross »L«

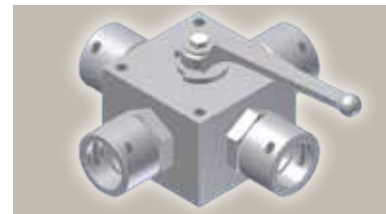
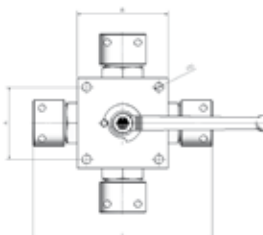

Part Number	Port Size				Pressure Rating max. working pressure		L mm	A mm	B mm	D mm
	DN	Inch	Size	mm	MPa	psi				
CMV25-06-1	10	3/8	-6	9.5	40.0	5800	150	65	80	6.5
CMV25-08-1	12	1/2	-8	12.7	40.0	5800	150	65	80	6.5
CMV25-12-1	19	3/4	-12	19.1	31.5	4500	170	80	100	9.0
CMV25-16-1	25	1	-16	25.4	25.0	3600	190	85	110	9.0

CMV26 Stecko® Block Ball Valve

Stecko Female Cross »X«

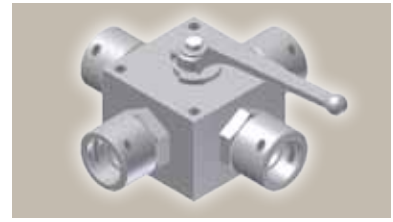
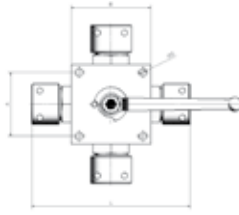

Part Number	Port Size				Pressure Rating		L	A	B	D
	DN	Inch	Size	mm	max. working pressure	MPa				
CMV26-06-1	10	3/8	-6	9.5	40.0	5800	150	65	80	6.5
CMV26-08-1	12	1/2	-8	12.7	40.0	5800	150	65	80	6.5
CMV26-12-1	19	3/4	-12	19.1	31.5	4500	170	80	100	9.0
CMV26-16-1	25	1	-16	25.4	25.0	3600	190	85	110	9.0

CMV27 Stecko® Block Ball Valve

Stecko Female Cross »L« Compact

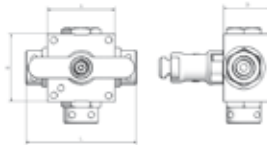

Part Number	Port Size				Pressure Rating		L	A	B	D
	DN	Inch	Size	mm	max. working pressure	MPa				
CMV27-06-5	10	3/8	-6	9.5	40.0	5800	102	52	52	65

CMV30 Super SteckO® Block Ball Valve

Super SteckO Male – Female

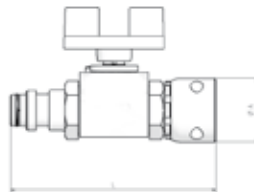

Part Number	Port Size				Pressure Rating		L	A
	DN	Inch	Size	mm	max. working pressure	MPa		
CMV30-08-4	12	1/2	-8	12.7	52.0	7500	128	38
CMV30-12-4	19	3/4	-12	19.1	42.0	6000	160	45
CMV30-16-3*	25	1	-16	25.4	38.0	5500	204	60
CMV30-20-3*	31	1 1/4	-20	31.8	35.0	5000	214	70
CMV30-24-3*	38	1 1/2	-24	38.1	35.0	5000	260	82
CMV30-32-3*	51	2	-32	50.8	35.0	5000	260	95

CMV31 Super SteckO® Block Ball Valve

Super SteckO Female

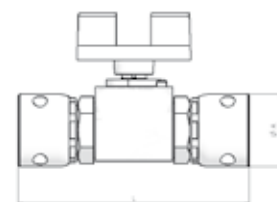

Part Number	Port Size				Pressure Rating		L	A
	DN	Inch	Size	mm	max. working pressure	MPa		
CMV31-08-4	12	1/2	-8	12.7	52.0	7500	124	38
CMV31-12-4	19	3/4	-12	19.1	42.0	6000	160	45
CMV31-16-3*	25	1	-16	25.4	38.0	5500	200	60
CMV31-20-3*	31	1 1/4	-20	31.8	35.0	5000	206	70
CMV31-24-3*	38	1 1/2	-24	38.1	35.0	5000	260	82
CMV31-32-3*	51	2	-32	50.8	35.0	5000	260	95

CMV32 Super SteckO® Block Ball Valve

Super SteckO Male

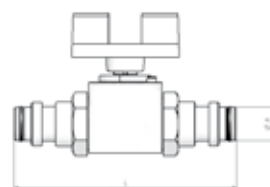

Part Number	Port Size				Pressure Rating		L	A
	DN	Inch	Size	mm	max. working pressure	MPa		
CMV32-08-4	12	1/2	-8	12.7	50.0	7250	132	15
CMV32-12-4	19	3/4	-12	19.1	42.0	6000	166	21
CMV32-16-3*	25	1	-16	25.4	38.0	5500	210	20
CMV32-20-3*	31	1 1/4	-20	31.8	35.0	5000	222	20
CMV32-24-3*	38	1 1/2	-24	38.1	35.0	5000	260	41
CMV32-32-3*	51	2	-32	50.8	35.0	5000	260	46

*starting with size -16, Ball Valves are equipped with handle type 3 (hexagon), see also page 25

CMV40 Block Ball Valve

BSP Female

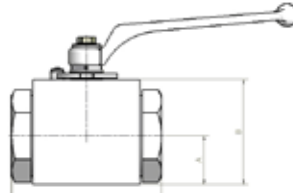

Part Number	Port Size				Pressure Rating		L	A	B	Thread BSP
	DN	Inch	Size	mm	max. working pressure	MPa				
CMV40-02-1	4	1/8	2	3.2	50.0	7250	50	12.5	30	1/8
CMV40-04-1	6	1/4	-4	6.4	50.0	7250	50	12.5	30	1/4
CMV40-05-1	8	5/16	-5	7.9	50.0	7250	65	15.0	40	5/16
CMV40-06-1	10	3/8	-6	9.5	50.0	7250	65	15.0	40	3/8
CMV40-08-1	12	1/2	-8	12.7	50.0	7250	72	18.0	45	1/2
CMV40-12-1	19	3/4	-12	19.1	31.5	4500	77	24.0	55	3/4
CMV40-16-1	25	1	-16	25.4	31.5	4500	92	30.0	65	1

Accessories

Overview

Hose Protection

SG	Spring Guard	F-1
AG	Armour Guard	F-1
AS	Partek® Nylon Protective Sleeve	F-2
PS	Partek® Nylon Protective Sleeve	F-3
FS-F	Fire Sleeves	F-4
PSG	Parker Spiral Guard	F-5
DMS	Minesleeve	F-6
TV	Shrink sleeve	F-7
PS	Partek Wrap	F-7
HP-B	Hose Shield	F-8
HS	Containment Grips	F-8

Hose Whip Restraint

Cable Assemblies	F-9
Hose collars	F-9
Cable Assemblies	F-9

Flange

M1H / 51H	ISO 6162-1 Flange Half – Standard Series	F-10
50H	ISO 6162-1 Flange Half 5000 psi	F-10
M2H	ISO 6162-2 Flange Half 6000 psi	F-10
8FH	Flange Half 8000 psi	F-10
Flange System	ISO 6162-1 (35.0 MPa/ 5000 psi)	F-11
Flange System	ISO 6162-2 (42.0 MPa/ 6000 psi)	F-11

O-Rings

711509	O-rings for SAE fittings (05 end configuration)	F-12
2-0	O-rings for ORFS male (JD and JM end configuration)	F-12
EARG/VURG/VERG	O-rings for BSP fittings	F-12
2-2	O-rings for SAE flanges	F-13
CARG	O-rings for metric 24° female swivel hose-end fittings	F-13
XARG	Flange "D" rings Caterpillar® style flanges	F-13

SG – Spring Guard

Spring Guards protect the hose cover against abrasion and are constructed of steel wire and plated to resist rust.

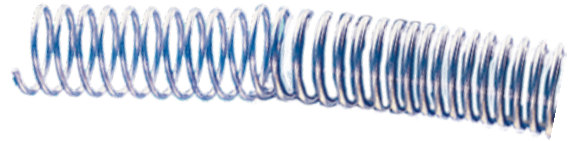

Hose \ I.D. Part Number	15.20	16.75	18.25	21.30	24.60	26.90	28.70	30.95	33.25	39.35	42.15	46.20	53.05	55.85	58.90	68.55	74.20	93.70
301TC		-4	-5	-6	-8	-10		-12		-16			-20		-24		-32	
462TC, CM2H, CM2HP	-4	-5	-6	-8	-10		-12			-16		-20	-24			-32		-40/-48
CM4SPP					-6	-8		-10	-12	-16			-20		-24			
722TC				-6	-8		-10		-12	-16			-20	-24		-32		
731TC, M4SHP									-12		-16		-20		-24		-32	
881									-12	-16		-20		-24		-32		-48
R35TC																		-40
CM4R42P								-10	-12		-16		-20		-24		-32	
787TC, 797TC				-8		-10		-12		-16		-20		-24		-32		

AG – Armour Guard

For extreme abrasion or possible damage from the outside, the corrosion-protected steel flat coil sleeve is recommended.



Hose \ I.D. Part Number	15.20	16.75	18.25	21.30	24.60	26.90	28.70	30.95	33.25	39.35	40.85	42.15	46.20	53.05	58.90	68.55	74.20	81.00
301TC		-4	-5	-6	-8	-10		-12		-16			-20	-24		-32		
462TC, CM2H, CM2HP	-4	-5	-6	-8	-10		-12			-16			-20	-24		-32		-40
CM4SPP					-6	-8		-10	-12	-16			-20	-24				
722TC				-6	-8		-10		-12	-16			-20		-32			
731TC, CM4SHP									-12			-16	-20	-24		-32		
881									-12	-16			-20		-32		-40	
CM4R42P								-10	-12		-16		-20	-24		-32		
787TC, 797TC			-6	-8		-10		-12		-16			-20	-24		-32		

AS – Partek® Nylon Protective Sleeve

Parker's Partek Nylon Protective Sleaving gives you tough hose abrasion protection two ways. First, per the ISO 6945 specification, Partek has a unique tubular weave nylon construction, Partek "AS" is strong enough to withstand greater than 200,000 abrasion cycles without wearing through the fabric at any location. In addition, this weave also gives an exceptionally smooth interior wall, allowing rubber hose to move freely inside the sleeve. This provides easy installation and prevents any internal abrasion problems. Partek sleeving is available in either black or yellow and in sizes to fit most hydraulic hose. Partek, the quick and easy solution to hose protection in high-abrasion areas.



Temperature Range -55 °C up to +120 °C

Part Number		I.D. round		I.D. flat	
		mm	Inch	mm	Inch
black	yellow				
AS-B-11	AS-Y-11	19	0.75	27	1.07
AS-B-13	AS-Y-13	24	0.93	34	1.34
AS-B-15	AS-Y-15	29	1.13	42	1.66
AS-B-17	AS-Y-17	31	1.22	46	1.82
AS-B-19	AS-Y-19	34	1.35	51	2.02
AS-B-22	AS-Y-22	36	1.43	54	2.13
AS-B-27	AS-Y-27	41	1.63	62	2.45
AS-B-33	AS-Y-33	46	1.81	70	2.75
AS-B-35	AS-Y-35	56	2.19	85	3.33
AS-B-37	AS-Y-37	60	2.38	92	3.63
AS-B-39	AS-Y-39	67	2.63	102	4.02
AS-B-45	AS-Y-45	73	2.88	113	4.43
AS-B-47	AS-Y-47	80	3.13	122	4.80
AS-B-53	AS-Y-53	86	3.38	132	5.20
AS-B-58	AS-Y-58	92	3.63	142	5.59
AS-B-64	AS-Y-64	102	4.00	157	6.18

PS – Partek® Nylon Protective Sleeve

Parker's Partek Nylon Protective Sleaving gives you tough hose abrasion protection two ways. First, per the ISO 6945 specification, Partek has a unique tubular weave nylon construction, Partek "PS" is strong enough to withstand greater than 50,000 abrasion cycles without wearing through the fabric at any location. In addition, this weave also gives an exceptionally smooth interior wall, allowing rubber hose to move freely inside the sleeve. This provides easy installation and prevents any internal abrasion problems. Partek sleeving is available in either black or yellow and in sizes to fit most hydraulic hose. Partek, the quick and easy solution to hose protection in high-abrasion areas.



Temperature Range -55 °C up to +120 °C

Part Number	I.D. round		I.D. flat	
	mm	Inch	mm	Inch
PS-B-12	19	0.75	27	1.08
PS-B-13	23	0.91	34	1.32
PS-B-15	27	1.06	40	1.56
PS-B-17	31	1.22	46	1.82
PS-B-22	36	1.42	54	2.14
PS-B-33	46	1.81	70	2.75
PS-B-35	56	2.19	85	3.33
PS-B-37	60	2.38	92	3.63
PS-B-39	67	2.63	102	4.02
PS-B-45	73	2.88	113	4.43
PS-B-47	80	3.13	122	4.8
PS-B-80	127	5.00	197	7.75
PS-B-88	140	5.50	217	8.54

FS-F – Fire Sleeves

Parker Firesleeve is a flame resistant sheath that protects the hose from extreme temperature conditions. Firesleeve easily slides over hoses and readily expands over fitting. When fitting the fire sleeve to hose assemblies with reusable or crimped fittings, a fire sleeve clamp must be used.



- Certification:
 - UL 1441 Certified
 - VW1 Flame Test Certified
 - MSHA Certified for use in underground mines
 - SAE AS1072E
 - GL-Germanischer Lloyd Certified for 800 °C for 30 min.
 - BS EN 373 Molten Splash Tested
 - BS EN 388 Abrasion Tested
 - BS EN ISO 6940 Flame Resistance Tested
 - BS EN ISO 6530 Oil Resistance Tested
 - BS 2576 Tensile Strength Tested
 - DIN 54837/5510-2 Rail Vehicle Certified for Resistance to Combustibility
 - DIN 5659-2/5510-2 Rail Vehicle Certified for Toxicity
 - MIL-C-24576A
 - PJA and P96 Thermal Conductivity

- Braided fiberglass sleeve with orange, bonded and seamless silicone rubber cover
- Conforms to SAE Aerospace Standard 1072A Type 2A

Temperature Range -54 °C up to +260 °C

Part Number	min. I.D.		max. O.D.		Suction Hose (R4)			1-/2-Wire Braided			Multispiral		
	mm	Inch	mm	Inch	inch	mm	size	inch	mm	size	inch	mm	size
FS-F-10	15	0.58	25	0.97				1/4	6	-4			
FS-F-11	17	0.65	26	1.03				1/4	6	-4			
FS-F-12	18	0.71	28	1.09				5/16	8	-5			
FS-F-14	21	0.84	31	1.22				3/8	10	-6			
FS-F-16	24	0.96	35	1.38				1/2	13	-8	1/4	6	-4
FS-F-18	27	1.08	38	1.50				1/2	13	-8	3/8	10	-6
FS-F-20	31	1.21	40	1.59				5/8	16	-10	1/2	13	-8
FS-F-22	34	1.34	44	1.75	3/4	19	-12	3/4	19	-12	5/8	16	-10
FS-F-24	37	1.46	48	1.90				1	25	-16	3/4	19	-12
FS-F-28	43	1.71	52	2.06	1	25	-16	1	25	-16	1	25	-16
FS-F-30	47	1.84	56	2.19									
FS-F-32	50	1.96	59	2.32	1 1/4	32	-20	1 1/4	32	-20			
FS-F-38	59	2.34	70	2.74			-24	1 1/4	32	-20	1 1/4	32	-20
FS-F-40	63	2.46	71	2.79				1 1/2	38	-24	1 1/2	38	-24
FS-F-48	75	2.96	86	3.40	2	51	-32						
FS-F-60	94	3.71	105	4.15	2 1/2	65	-40	2 1/2	65	-40	2 1/2	65	-40
					3	76	-48	3	76	-48	2 1/2	65	-40

PSG – Parker Spiral Guard

- High-strength and resilient, Spiral Guard protects hose and cable with superior anti-crush performance
- Exceptionally smooth facing and rounded edges prevent Spiral Guard from getting caught on rough surfaces
- Easy installation and routing
- Low friction interior minimizes wear on hose
- For bundling, organizing and protecting hose and cable, Parker Spiral Guard is the superior solution for mining operations
- Approvals: MSHA



Part Number	Hose O.D. Range		Suction Hose (R4)			1-/2-Wire Braided			Multi-Spiral		
	mm	Inch	inch	mm	size	inch	mm	size	inch	mm	size
PG-FRAS-16	12 – 17	0.47 - 0.67	-	-	-	1/4	6	-4	-	-	-
PG-FRAS-20	16 – 22	0.63 - 0.87	-	-	-	5/16 3/8	8 10	-5 -6	1/4 3/8	6 10	-5 -6
PG-FRAS-25	22 – 28	0.87 - 1.10	-	-	-	1/2 5/8	13 16	-8 -10	1/2 5/8	13 16	-8 -10
PG-FRAS-32	27 – 33	1.06 - 1.30	3/4	19	-12	5/8 3/4	16 19	-10 -12	5/8 3/4	16 19	-10 -12
PG-FRAS-40	33 – 42	1.30 - 1.65	1	25	-16	1	25	-16	1	25	-16
PG-FRAS-50	42 – 55	1.65 - 2.17	1-1/4	32	-20	1-1/4 1-1/2	32 38	-20 -24	1-1/4	32	-20
PG-FRAS-63	52 – 65	2.05 - 2.56	1-1/2	38	-24	1-1/2 2	38 51	-24 -32	1-1/2	38	-24
PG-FRAS-75	65 – 80	2.56 - 3.15	2 2 1/2	51 65	-32 -40	2 2 1/2	51 65	-32 -40	2	51	-32
PG-FRAS-90	80 – 150	3.15 - 5.91	3	75	-48	3	75	-48	2 1/2 3	65 75	-40 -48

DMS – Minesleeve

Parker Minesleeve offers the best abrasion resistance without adding stiffness to hose assemblies and exceeds the MSHA specifications for flame resistance and flame propagation. Burst tests performed according to SAE J343 on hose assemblies covered with Minesleeve (DMS) show an oil spill retention capability of 7 times greater than similar products. Also suitable for bundling small hose assemblies, tubing or wires.



- Abrasion resistance
 - offers the best abrasion resistance without adding stiffness to hose assemblies
- Fire & flame resistance
 - exceeds US MSHA specifications for flame resistance & flame propagation
- Electrical conductivity
 - tests performed to ISO 8031 on hose assemblies covered with minesleeve show electrical conductivity values well below the specification requirements
- Oil spill retention
 - burst tests performed according to SAE J343 on hose assemblies covered with minesleeve show an oil spill retention capability of 7 times greater than similar products, also suitable for bundling small hose assemblies, tubing or wires
- Approvals: MSHA & UK COAL

Temperature Range -50 °C up to +120 °C

Part Number	I.D. round		I.D. flat	
	mm	Inch	mm	Inch
DMS-23	23	0.91	39	1.54
DMS-27	27	1.06	45	1.77
DMS-31	31	1.22	52	2.05
DMS-36	36	1.42	57	2.24
DMS-47	47	1.85	77	3.03
DMS-55	55	2.17	89	3.5
DMS-66	66	2.60	107	4.21
DMS-85	85	3.35	136	5.35
DMS-93	93	3.66	149	5.87
DMS-127	127	5.00	197	7.75

TV – Shrink sleeve

Cross-linked polyolefin heat-shrinkable tube with adhesive sealing. Its exceptional mechanical capabilities make TV ideal for fixation of protective sleeves on hydraulic hose assemblies in underground and above-ground applications.



- Shrink ratio: up to 3.5 : 1
- Material: Polyolefin
- Usage temperature: -45 °C to +110 °C
- Shrink temperature: min. 110 °C
- Standard color: black
- Flammability: flame retardent, hardly inflammable

Part Number	Diameter	Diameter after shrink	Wallthickness after shrink
	mm	mm	mm
TV28/6	28	6	2.5
TV33/8	33	8	2.5
TV40/12	40	12	2.5
TV55/16	55	16	2.7
TV75/22	75	22	3
TV95/25	95	25	3
TV115/34	115	34	3
TV140/42	140	42	3

PS – Partek Wrap

Nylon hose sleeve designed for bundling hose assemblies after installation

- Post-assembly installation
- Light weight and high flexibility
- Urethane-coated 1050 ballistic Nylon
- Ambient temperature range of -51 °C to 93 °C
- Fast and easy installation
- Designed for added abrasion resistance or bundling of multiple hoses
- Can be cut to size with household scissors



Part Number	Hose Bundle O.D.		Circumference	Roll Length	Color
	Inch	mm			
PS-BV-300	3	76.2	238.8	15.24	black
PS-BV-400	4	101.6	317.5	15.24	black
PS-BV-500	5	127.0	400.0	15.24	black
PS-BV-700	7	177.8	558.8	15.24	black

HP-B – Hose Shield

Hose protection shields extend hose life by protecting the hose from abrasion that occurs when hose rubs against other hose, metal or concrete. Parker hose shields are resistant to oil, lubricants, gasoline, most solvents and can withstand ambient temperatures from -40 °C to +150 °C. Easily installed and secured by cable ties without disconnecting any hose lines.

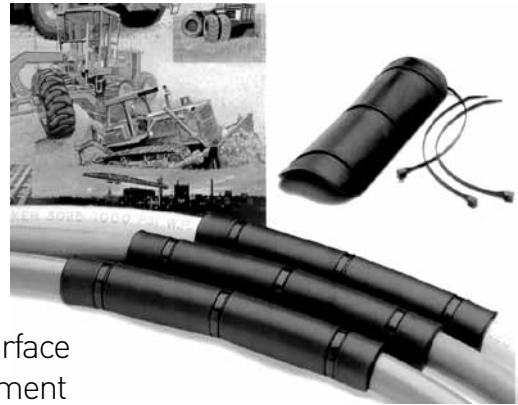

- Use with hose from size -4 up to size -32
- Eliminate hose abrasion on concrete, metal or any rough surface
- Guard against hose deterioration on mobile hydraulic equipment
- Let Parker fill all your hydraulic and pneumatic hose product needs

Hose Shields KIT HP-B-13X18-KIT with – 2 x HP-13 RFL Hose Protectors, length 101 mm (4") – 2 x HP-15 RFL Hose Protectors, length 152 mm (6") – 4 x HP-18 RFL Hose Protectors, length 203 mm (8") – 30 x HT-12 Tie Wraps – 30 x HT-16 Tie Wraps – 15 x HT-22 Tie Wraps	Part Number	HP-B-13X18-KIT
Counter Display HP-B-13-RFL with – 10 x HP-B-13 Hose Protectors, length 101 mm (4") – 30 x HT-12 Tie Wraps	Part Number	HP-B-13-RFL
Counter Display HP-B-15-RFL with – 10 x HP-B-15 Hose Protectors, length 152 mm (6") – 30 x HT-16 Tie Wraps	Part Number	HP-B-15-RFL
Counter Display HP-B-18-RFL with – 5 x HP-B-18 Hose Protectors, length 203 mm (8") – 15 x HT-18 Tie Wraps	Part Number	HP-B-18-RFL
Hose Protector , length 101 mm (4")	Part Number	HP-B-13
Hose Protector , length 152 mm (6")	Part Number	HP-B-15
Hose Protector , length 203 mm (8")	Part Number	HP-B-18

HS – Containment Grips

- Material: electrogalvanized steel wire

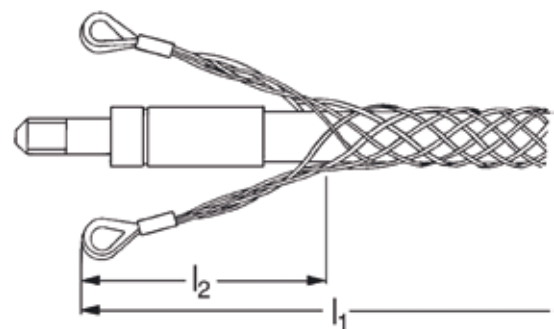

Part Number	Hose I.D.				Ø mm	Working load kN	Breaking load kN	Total length l1 mm	Length of loops l2 mm
	DN	Inch	Size	mm					
HS-03	5	3/16	-3	4.8	9 - 15	3	9	600	200
HS-05	8	5/16	-5	7.9	12 - 20	6	18	600	200
HS-08	12	1/2	-8	12.7	20 - 30	11	33	600	200
HS-12	20	3/4	-12	19.0	30 - 40	11	33	600	200
HS-16	25	1	-16	25.4	40 - 50	16	48	600	200

Hose Whip Restraint

Safety Restraining System for Pressure Hoses

- Prevents whipping of a pressurized hose in the event of the hose separating from its fitting
- The system consists of two parts
 - a hose collar and a cable assembly



Part Number	A		B	
	Inch	mm	Inch	mm
WRC1212	0.47	12	0.492	12.5
WRC1313	0.51	13	0.531	13.5
WRC1415	0.55	14	0.591	15
WRC1718	0.67	17	0.709	18
WRC1819	0.71	18	0.748	19
WRC2021	0.79	20	0.827	21
WRC2223	0.87	22	0.906	23
WRC2425	0.95	24	0.984	25
WRC2526	0.98	25	1.024	26
WRC2728	1.06	27	1.102	28
WRC2829	1.10	28	1.142	29
WRC3031	1.18	30	1.220	31
WRC3435	1.34	34	1.378	35
WRC3637	1.42	36	1.457	37
WRC3839	1.50	38	1.535	39
WRC4445	1.73	44	1.772	45
WRC4547	1.77	45	1.850	47
WRC4850	1.89	48	1.969	50
WRC5153	2.01	51	2.087	53
WRC5456	2.13	54	2.205	56
WRC5759	2.25	57	2.330	59
WRC6365	2.48	63	2.559	65
WRC6971	2.72	69	2.795	71
WRC7577	3.00	75	3.030	77
WRC8486	3.30	84	3.380	86
WRC8789	3.42	87	3.500	89

Hose collars

for Hose Whip Restraint System

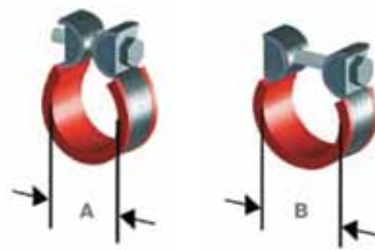

Cable Assemblies

for hoses attached with port adapters



Cable Assemblies

for hoses using flange-style connections
(code 61 and code 62 flanges)



Part Number	A		C	
	Inch	mm	Inch	mm
WRF085	0.33	8.5	11.81	300
WRF105	0.41	10.5	17.72	450
WRF125	0.49	12.5	17.72	450
WRF145	0.57	14.5	17.72	450
WRF165	0.65	16.5	17.72	450
WRF205	0.81	20.5	17.72	450

Part Number	A		C	
	Inch	mm	Inch	mm
WRA145	0.57	14.5	11.81	300
WRA170	0.67	17.0	11.81	300
WRA185	0.73	18.5	11.81	300
WRA205	0.81	20.5	11.81	300
WRA225	0.89	22.5	11.81	300
WRA245	0.96	24.5	11.81	300
WRA265	1.04	26.5	11.81	300
WRA305	1.20	30.5	11.81	300
WRA340	1.34	34.0	17.72	450
WRA365	1.44	36.5	17.72	450
WRA425	1.67	42.5	17.72	450
WRA455	1.79	45.5	17.72	450
WRA490	1.93	49.0	17.72	450
WRA525	2.07	52.5	17.72	450
WRA600	2.36	60.0	17.72	450

Flange Half

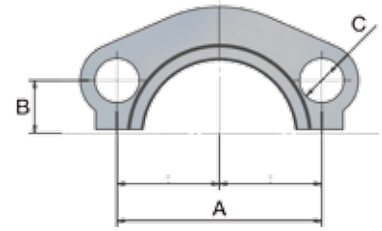

M1H / 51H – ISO 6162-1 Flange Half – Standard Series

ISO 6162

Part Number	Flange			A mm	B mm	C mm	max. dynamic working pressure	
	DN	Inch	Size				MPa	psi
M1H-8	13	1/2	-8	38.1	8.7	9.0	34.5	5000
M1H-12	19	3/4	-12	47.6	11.1	11.0	34.5	5000
M1H-16	25	1	-16	52.4	13.1	11.0	34.5	5000
51H-20	32	1-1/4	-20	58.7	15.1	12.0	27.5	4000
51H-24	38	1-1/2	-24	69.9	17.9	13.5	21.0	3000
51H-32	51	2	-32	77.7	21.4	13.5	21.0	3000

50H – ISO 6162-1 Flange Half 5000 psi

ISO 6162 (For use with 4A, 4F and 4N flanges)

Part Number	Flange			A mm	B mm	C mm	max. dynamic working pressure	
	DN	Inch	Size				MPa	psi
50H-20	32	1-1/4	-20	58.7	15.1	12.0	34.5	5000
50H-24	40	1-1/2	-24	69.9	17.9	13.5	34.5	5000
50H-32	50	2	-32	77.7	21.4	13.5	34.5	5000

M2H – ISO 6162-2 Flange Half 6000 psi

ISO 6162

Part Number	Flange			A mm	B mm	C mm	max. dynamic working pressure	
	DN	Inch	Size				MPa	psi
M2H-8	13	1/2	-8	40.5	9.1	9.0	41.0	6000
M2H-12	19	3/4	-12	50.8	11.9	11.0	41.0	6000
M2H-16	25	1	-16	57.2	13.9	13.0	41.0	6000
M2H-20	32	1-1/4	-20	66.6	15.9	15.0	41.0	6000
M2H-24	38	1-1/2	-24	79.2	18.2	17.0	41.0	6000
M2H-32	51	2	-32	96.8	22.2	22.0	41.0	6000

8FH – Flange Half 8000 psi

Part Number	Flange			A mm	B mm	C mm	max. dynamic working pressure	
	DN	Inch	Size				MPa	psi
8FH-12-SM	20	3/4	-12	50.80	10.90	11.0	56.0	8000
8FH-12	20	3/4	-12	50.80	10.90	10.4	56.0	8000
8FH-16-SM	25	1	-16	57.15	12.95	13.0	56.0	8000
8FH-16	25	1	-16	57.20	13.00	11.9	56.0	8000
8FH-20-SM	32	1-1/4	-20	66.70	15.00	13.0	56.0	8000

Full Flange System

Provides full flange mounting option for ISO 6162-1 (35.0 MPa/5000 psi) and ISO 6162-2 (42.0 MPa/ 6000 psi) flanges – system flexibility reduces inventory investment.



Once the hose fitting is crimped to the hose, the flange is placed over the fitting end and then is held in place with the retaining ring. When the flange engages the retaining ring, the flange is held securely and is ready to be bolted to the port. Installation to the port is easy – there is no fumbling with the flange halves, and the flange can be rotated for ease of assembly to the port. The full flange system can be used repeatedly because of its patent-pending attachment system – the flange is not permanently locked onto the fitting.

Flange System

ISO 6162-1 (35.0 MPa/ 5000 psi)*

SAE Flanges Size	max. working pressure	Flange	Seal	Retaining Ring
Inch	psi	Part Number	Part Number	Part Number
3/4	5000	R-312-CFX	XRG-12	R12X
1	5000	R-316-CFX	XRG-16	R16X
1 1/4	5000	R-320-CFX	XRG-20	R20X
1 1/2	5000	R-324-CFX	XRG-24	R24X
2	5000	R-332-CFX	XRG-32	R32X
2 1/2	5000	R-340-CFX	XRG-40	R40X
3	3000	R-348-CFX	XRG-48	R48X

Flange System

ISO 6162-2 (42.0 MPa/ 6000 psi)*

SAE Flanges Size	max. working pressure	Flange	Seal	Retaining Ring
Inch	psi	Part Number	Part Number	Part Number
3/4	6000	R-612-CFX	XRG-12	R12X
1	6000	R-616-CFX	XRG-16	R16X
1 1/4	6000	R-620-CFX	XRG-20	R20X
1 1/2	6000	R-624-CFX	XRG-24	R24X
2	6000	R-632-CFX	XRG-32	R32X
2 1/2	5000	R-640-CFX	XRG-40	R40X
3	3000	R-648-CFX	XRG-48	R48X



* 2 1/2 inch max. 35.0 MPa/ 5000 psi
3 inch max. 21.0 MPa/ 3000 psi

O-Rings



Fittings are supplied with O-rings made from ozone-resistant Nitrile (NBR) rubber compound suitable for temperatures from -40 °C up to +120 °C

On request: Viton® (FPM) compound from -25 °C up to +200 °C
Ethylene-Propylene (EPDM) compound from -55 °C up to +150 °C



711509 – O-rings for SAE fittings (05 end configuration)

Part Number	 mm	 mm	Thread	
			UNF	Size
711509-1	8.92	1.83	7/16x20	-4
711509-2	10.52	1.83	1/2x20	-5
711509-3	11.89	1.98	9/16x18	-6
711509-4	16.36	2.21	3/4x16	-8
711509-5	19.18	2.45	7/8x14	-10
711509-6	23.47	2.95	1-1/16x12	-12
711509-7	29.74	2.95	1-5/16x12	-16
711509-8	37.47	3.00	1-5/8x12	-20

2-0 – O-rings for ORFS male (JD and JM end configuration)



Part Number	 mm	 mm	Thread	
			UNF	Size
2-011N552-90	7.65	1.78	9/16x18	-4
2-012N552-90	9.25	1.78	11/16x16	-6
2-014N552-90	12.42	1.78	13/16x16	-8
2-016N552-90	15.60	1.78	1x14	-10
2-018N552-90	18.77	1.78	1-3/16x12	-12
2-021N552-90	23.52	1.78	1-7/16x12	-16
2-025N552-90	29.87	1.78	1-11/16x12	-20
2-029N552-90	37.82	1.78	2x12	-24

EARG/VURG/VERG – O-rings for BSP fittings



Part Number	 mm	 mm	Thread	
			UNF	Size
EARG-4	6.0	1.0	1/4x19	-4
C9RG-10	8.5	1.5	3/8x19	-6
VURG-4	12.0	1.5	1/2x14	-8
EARG-10	13.1	1.6	5/8x14	-10
VERG-14	17.0	1.5	3/4x14	-12
VERG-19	21.0	1.5	1x11	-16
EARG-20	29.5	1.5	1-1/4x11	-20

O-Rings



2-2 – O-rings for SAE flanges

Part Number				
	mm	mm	UNF	Size
2-210N552-90	18.64	3.53	1/2	-8
2-214N552-90	24.99	3.53	3/4	-12
2-219N552-90	32.92	3.53	1	-16
2-222N552-90	37.69	3.53	1-1/4	-20
2-225N552-90	47.22	3.53	1-1/2	-24
2-228N552-90	56.74	3.53	2	-32
2-232N552-90	69.44	3.53	2-1/2	-40

CARG – O-rings for metric 24° female swivel hose-end fittings

Part Number					
	mm	mm	light series metric	heavy series metric	Tube O.D. mm
CARG-6	4.5	1.5	M12x1.5	M14x1.5	6
C9RG-8	6.5	1.5	M14x1.5	M16x1.5	8
C9RG-10	8.5	1.5	M16x1.5	M18x1.5	10
C9RG-12	10.5	1.5	M18x1.5	M20x1.5	12
C9RG-14	12.0	2.0		M22x1.5	14
CARG-15	12.5	2.0	M22x1.5		15
C9RG-16	14.0	2.0		M24x1.5	16
CARG-18	16.0	2.0	M26x1.5		18
C9RG-20	17.0	2.5		M30x2	20
CARG-22	20.0	2.0	M30x2		22
C9RG-25	22.0	2.5		M36x2	25
CARG-28	26.0	2.0	M36x2		28
C9RG-30	27.0	2.5		M42x2	30
CARG-35	32.0	2.5	M45x2		35
C9RG-38	35.0	2.5		M52x2	38
CARG-42	39.0	2.5	M52x2		42

XARG – Flange “D” rings Caterpillar® style flanges

Part Number				
	mm	mm	UNF	Size
XARG-12	25.4	5.0	3/4	-12
XARG-16	31.9	5.0	1	-16
XARG-20	38.2	5.0	1-1/4	-20
XARG-24	44.7	5.0	1-1/2	-24
XARG-32	63.9	5.0	2	-32

Machines Overview

Crimping

Parkrimp System

KarryKrimp® 2	G-1
KarryKrimp Bench Mount	G-2
Parkrimp® 2	G-3
Die Sets	G-4

Adjustable Crimper

TH 8E-200-BM	G-5
TH 8E-325-BM	G-6
TH 8E-380-BM	G-7

Hose Cutting

TH 3E-EM3	G-8
TH 3E-82M	G-9
TH 3E 115	G-10
TH 3E-110	G-11

Marking

TH 4-4 U, TH 4E-11	G-12
--------------------	------

Cleaning

TH 6-10-EL-7	Ultra Clean Kit	G-13
--------------	-----------------	------

Testing

TH 5-3	Hose Assembly Test Bench	G-15
--------	--------------------------	------

CrimpCharts

www.parker.com/crimpsource-euro



KarryKrimp® 2

Modular portable crimper
for braided and multispiral hoses

- Crimps
 - 1 and 2 steel wire or textile braided hoses up to size -20
 - 3 steel wire braided hoses up to size -16
 - 4 layer multispiral hoses up to size -16
 - compact spiral hoses up to size -12
- Available in modular design with all Parkrimp system advantages
- The same unit offers portability and bench mountability
- Easily portable for outside work
- Portable, compact rugged design
- Pivoting pusher design for easy die change out

Primary Applications

Small workshops, repair shops, mobile service vehicles.
Crimps both steel and stainless steel fittings.

Fittings Series

26, 46, 48, 70, 71, 73, 77, 78

Technical / Order Data

KarryKrimp 2	Dimensions	H 805 x W 340 x D 350 mm
	Weight	46 kg
	Part Number	85CE-061L

Included standard equipment

<i>Crimp head</i>		Part Number	85CE-CHD
<i>Stand assembly</i>		Part Number	85C-STD
<i>Hose assembly</i>		Part Number	85C-00L
<i>Die rings</i>	silver	Part Number	85C-R01
	black	Part Number	85C-R02

Crimping presses

Hand pump 85CE-0HP



Working pressure	max. 70 MPa
Dimensions	L 580 x W 150 x H 195 mm
Weight	10.7 kg
Usable oil capacity	2200 ccm
Lever force	35 kg
Part Number	85CE-0HP

Turbo air pump 85C-0AP



Working pressure	70 MPa
Dimensions	L 350 x W 170 x H 210 mm
Weight	8.2 kg
Usable oil capacity	2080 ccm
Connection	air 1/4-18 NPTF thread
Part Number	85C-0AP



Restrictions

Not suitable for 2-piece fittings.

KarryKrimp Bench Mount

Modular crimpers with
Bench Power Unit for workshops

- In addition to the portable versions, the sole crimping units can be used with the Bench Power Unit for workshop versions
- Faster cycle times for increased productivity
- Increased height for longer elbows or bent tube fittings
- The crimpers and the Bench Power Unit are supplied separately



Modular Design = Portable + Bench Mount

The new modular design enables the customer to choose between the portability that Parker KarryKrimp crimpers have always offered, and the new option to make these same crimpers bench mount units. The modular design gives users the flexibility of a portable crimper with the advantage of increased productivity when connected to the Bench Power Unit 85CE-1PE.



Technical / Order Data

**Bench Power Unit
85CE-1PE**



Working pressure	70 MPa
Dimensions	L 425 x W 525 x H 460 mm
Weight	62 kg
Usable oil capacity	8000 ccm
Electrical power	230 V / 50/60 Hz / 10 A
Part Number	85CE-1PE

Parkrimp® 2 Crimping Press 83CE-083U

Bench-mounted crimper for all Parkrimp
No-Slave hose types from size -4 up to size -32,
including 4 and 6 layer multispiral hoses

- Crimps
 - 1 and 2 steel wire or textile braided hoses up to size -32
 - 3 steel wire braided compact up to size -16
 - 4 and 6 layer multispiral hoses up to size -32
 - compact spiral hoses up to size -16
- Used for service with 400 V hydraulic power unit



Primary Applications

Workshops and repair shops (for small series).
Crimps both steel and stainless steel fittings.

Restrictions

Not suitable for 2-piece fittings.

Fittings Series

26, 46, 48, 70, 71, 73, 76, 77, 78, 79, S6

Technical / Order Data

Parkrimp 2 with power unit, bench-mounted,
but without die sets, connector plug and oil

Electrical power	400 V / 4.4 kW / 8.9 A / 50 Hz	
Dimensions	H 1170 x W 530 x D 985 mm	
Weight	without packaging	370 kg
	with packaging	430 kg
Part Number	83CE-083U	
Adaptor bowl	Part Number	83C-0CB
Die ring	Part Number	83C-R02

Parkrimp® Die Sets

Parker`s Colour-Coded Die Sets

- Chain link keeps segments together
- No loose parts to mismatch or misplace
- The crimp die provides 360-degree gripping power for greater impulse life



Note: *Please consult the pages **Ec** for assembly instructions. Die sets with the "H" suffix are used for jump sizes and certain metric fittings to permit insertion and removal of fittings. Die sets 80C-XX 8 segments are chained together. Die sets 83C-XX consist of two chained halves. Exceptions 83C-D06, -D08, -D10, -D12, -D16

Hose I.D. size		Die sets	Part Number				
DN	43 series		48 series	70 series	73 series	77 series	
-4	6	red	80C-A04	80C-C04			
-5	8	violet	80C-A05	80C-C05			
-6	10	yellow	80C-A06	80C-C06	83C-D06		
-8	12	blue	80C-A08	80C-C08	83C-D08		80C-CS08
-10	16	orange	80C-A10	80C-C10	83C-D10		80C-CS10
-12	20	green	80C-A12	80C-C12	83C-D12	83C-L12 or 80C-L12	80C-CS12
-16	25	black	80C-A16 or 83C-A16H	80C-C16	83C-D16 or 83C-D16H	83C-L16 or 80C-L16	83C-CS16
-20	32	white	80C-A20 or 83C-A20H*	80C-C20 or 83C-C20H*		83C-L20	83C-CS20
-24	40	red	83C-A24	83C-C24		83C-L24	83C-CS24
-32	50	green	83C-A32	83C-C32		83C-L32	83C-CS32

TH 8E-200-BM

Adjustable Crimping Press

- Crimps braided and spiral hoses
 - DIN/ EN 1 and 2 SN up to size -24
 - SAE 100 R12/DIN EN 4SP up to 1.1/4" (size -20)
 - SAE 100 R13 and R15 up to 1" (size -16)
- Die set system PB 239
- Separate hydraulic power unit for easy installation and lightweight construction
- User-friendly



Primary Applications

Workshops and repair shops.

Crimps both steel and stainless steel fittings.

Technical / Order Data

	Crimp force	130 t
	Crimp range	70 mm
	Type of dies	239
	Noise level	69 dBA
	Color	black/silver
	Electrical power	400 V / 50 Hz / 3 PH / 3 kW
	Control system	Control B + Touch
	Dimensions	L 800 x W 530 x H 560 mm
	Oil quantity	40 l
	Weight	160 kg
	Part Number	83CE-083U
TH 8E-200-BM with	Part Number	QDS239S
• Die set package PBSET-TH8E-200	Part Number	PBSET-TH8E-200
• Quick change tool QDC239.3	Part Number	QDC239.3
Die rack		
Die set package		
PB239 Ø 12, 14, 17, 20, 24, 28, 32, 36, 40, 44, 50, 54		
Quick change tool		

TH 8E-325-BM

Adjustable Heavy-Duty Crimping Press

- Crimps all Parker/ParLock hose types up to 4 or 6 spiral steel wire layers (DIN 4SP/4SH, SAE 100 R13 and SAE 100R15) up to size -24
- Crimps all Parker industrial hose types up to 4" (DN 100)



Primary Applications

Heavy-duty production crimper for crimping multispiral hoses in workshops for series production. Suitable for all standard Parker hoses.

Restrictions

Special hose assemblies with 2 elbows in extremely long version.

Technical / Order Data

TH 8E-325-BM with

- Control B + Touch
- Quick change tool QDC239.3
- Adapter die set package PB 237.239.2L2
- Die set package PBSET-TH8-325-BM

Electrical power	400 V / 59 Hz / 3 PH / 5.5 kW
Crimp force	280 t
No grease: 20 % less friction	✓
Control	Control B + Touch
SAE R12 / SAE R13 / SAE R15	2" / 2" / 1 1/2"
Industrial	4" (6" without flange)
90° Elbows	3"
Crimp range	161 mm
Opening / without dies	+ 70 mm / 215 mm
Type of dies	239 L / 237 L
Speed / Close	23 mm/sec.
Noise level	65 dB (A)
Dimensions	L 1600 x W 600 x H 1600 mm
Weight without oil / with oil	750 kg / 840 kg
Part Number	TH8E-325-BM
Part Number	PB237.239.2L2
Part Number	PBSET-TH8-800

Adapter die set package 237/239L

Die set package

PB 239L Ø 17, 20, 24, 28, 32, 40, 44, 50
PB 237L Ø 54, 57, 62, 67, 71, 74 + 237.239.2L2

TH 8E-380-BM

Adjustable Heavy-Duty Crimping Press

- Crimps all Parker/ParLock hose types up to 4 or 6 spiral steel wire layers (DIN 4SP/4SH, SAE 100 R13 and SAE 100R15) up to size -32
- Crimps all Parker industrial hose types up to 4" (DN 100)



Primary Applications

Heavy-duty crimper for crimping multispiral hoses in workshops for series production. Suitable for all standard Parker hoses.

Restrictions

Special hose assemblies with 2 elbows in extremely long version.

Technical / Order Data

TH 8E-380-BM with

- Adapter die set package PB237.239.2L2
- Quick change tool QDC239.3
- Die set package PBSET-TH8-380

For V4 and V6 fittings above size -16 long die sets are required (e.g. PB 237L-57)

Attention: Delivery without oil and connecting plug

Electrical power	400 V / 50 Hz / 3 PH / 5.5 kW
Crimp force	340 t
Control system	Control B + Touch
Crimp range	161 mm
Type of dies	237L / 239L
Open / Close speed	23 mm/s
Noise level	69 dB (A)
Dimensions	L 1600 x W 600 x H 1600 mm
Weight without oil / with oil	750 kg / 840 kg
Part Number	TH8E-380-BM
Part Number	PB237.239.2L2
Part Number	TA380/A
Part Number	QDS239S
Part Number	PBSET-TH8E-380
Part Number	PBSET-237L-IH
Part Number	FU-HMX
Part Number	SHS310/370
Part Number	QDC239.3
Part Number	TH8-LUS
Adapter die set package 237/239L	
Depth Stop Automatic	
Die rack	
Die set package	
PB 239L Ø 14, 17, 20, 24, 28, 32, 36, 40, 44, 50	
PB 237L Ø 54, 57, 62, 67, 71, 74, 78	
Die set package optional	
PB 237L Ø 84, 86, 90, 96, 103, 106, 111, 116, 121, 126, 131	
Foot switch	
Mirror set	
Quick change tool	
Workplace lamp	

TH 3E-EM3

Hose Cutting Machine

- Cuts
 - 1 and 2 steel wire or textile braided hoses up to size -20
 - 4 steel wire multispiral hoses up to size -20
 - Industrial hoses up to size -32
- According to the CE safety standards the blade stops within 10 seconds after switching off the brake motor
- Faster and safer cut using less energy, cutting motor with a larger shaft oversize bearing to guarantee less vibration created by radial forces
- Cutting blades approved on considered material



Primary Applications

Repair shops or mobile service vehicles

Restrictions

Not suitable for large bore industrial hoses.

Technical / Order Data

Hose Cutting Machine TH 3E-EM3

with cutting blade, serrated TM275x3x30Z

Electrical power	3 kW
Cutting blade	275 x 3 x 30 mm
Dimensions	W 540 x D 440 x H 300 mm
Weight	50 kg
Part Number	TH 3E-EM3
Cutting blade, serrated 275 x 3 x 30 mm	Part Number TM275x3x30Z

Cutting blade, serrated 275 x 3 x 30 mm

Part Number

TM275x3x30Z

TH 3E-82M

Hose Cutting Machine

- Cuts
 - 1 and 2 steel wire or textile braided hoses up to size -32
 - 4 steel wire multispiral hoses up to size -32
 - Industrial hoses up to size -64
- According to the CE safety standards the blade stops within 10 seconds after switching off the brake motor
- Faster and safer cut using less energy, cutting motor with a larger shaft oversize bearing to guarantee less vibration created by radial forces
- Cutting blades approved on considered material



Technical / Order Data

Hose Cutting Machine TH 3E-82M

with cutting blade, serrated TMG400x4x30

Electrical power	4.6 kW
Cutting blade	G400 x 4 x 30 mm
Dimensions	W 693 x D 940 x H 485 mm
Weight	110 kg
Part Number	TH 3E-82M
Part Number	TMG400x4x30

Cutting blade, serrated 400 x 4 x 30 mm

TH 3E-115

Hose Cutting Machine

- Cuts
 - all industrial hose types up to 75 mm O.D.
 - 1, 2 and 3 steel wire or textile braided hoses up to size -40
 - 4/6 steel wire multispiral hoses up to size -32
- According to the CE safety standards the blade stops within 10 seconds after switching off the brake motor
- Faster and safer cut using less energy, cutting motor with a larger shaft oversize bearing to guarantee less vibration created by radial forces
- Cutting blades approved on considered material
- Easiest cutting of big dimensioned hoses with more energy efficient machines



Primary Applications

Service and series production at workshops.

Technical / Order Data

Hose Cutting Machine TH3-15 3-phase, 400 Volt	Electrical power	230/400 V / 7.5 kW / 25 A / 50 Hz
	Exhaust system Ø	108 mm
	Cutting blade	520 x 4 x 40 mm
	Dimensions	L 1210 x W 650 x H 1650 mm
	Weight	245 kg
	Part Number	TH3E-115
Cutting blade, serrated 520 x 4 x 40 mm	Part Number	TMG520 x 4 x 40

TH 3E-110

Hose Cutting Machine

- Cuts
 - 1 and 2 steel wire or textile braided hoses up to size -48
 - 4 steel wire multispiral hoses up to size -48
 - Industrial hoses up to size -64
- According to the CE safety standards the blade stops within 10 seconds after switching off the brake motor
- Faster and safer cut using less energy, cutting motor with a larger shaft oversize bearing to gurantee less vibration created by radial forces
- Cutting blades approved on considered material
- Easiest cutting of big dimensioned hoses with more energy efficient machines



Technical / Order Data

Hose Cutting Machine TH 3E-82M with cutting blade, serrated TMG520x4x120	Electrical power	7.5 kW
	Cutting blade	520 x 4 x 120
	Dimensions	W 800 x D 780 x H 1700 mm
	Weight	280 kg
	Part Number	TH 3E-110
Cutting blade, serrated 520 x 4 x 120 mm	Part Number	TMG520x4x120

TH 4-4 U, TH 4E-11

Hand Marking Tools

- Hand marking tool for marking the crimp shells of 1- and 2-piece fittings up to size -32
- Permanent and easy marking in hose assembling workshops
- Type holder with two lines makes it possible to print additional information on the shell or fittings

TH 4E-11

- The cost efficient alternative



Primary Applications

Workshops and mobile service vehicles

Technical / Order Data

Hand Marking Tool TH 4-4 U including type case and quick-change stamping tool	Marking area	Ø O.D. 11.5 mm - 100 mm
	Dimensions	L 250 x W 340 x H 450 mm
	Type holder	2 lines
	Weight	35 kg
	Part Number	TH4-4U
Type case for TH 4-4 U	Part Number	UPTS 100
Quick-change stamping tool for TH 4-4 U single line	Part Number	UPTH-11b-PW3
Type holder for TH 4-4 U 2 lines	Part Number	UPTH-22b
Hand Marking Tool TH 4E-11 including type case and type holder	Marking area	Ø O.D. 8 mm - 80 mm
	Dimensions	L 285 x W 265 x H 410 mm
	Type holder	1 line
	Weight	12 kg
	Part Number	TH4E-11
Type case for TH 4E-11	Part Number	TH4E-11-TC
Type holder for TH 4E-11	Part Number	TH4E-11-TH



Stamping tool
UPTH-11b-PW3

Type case UPTS 100 content

Letters: 1x P, 1x N, 3x letters empty
Numbers: 6 x 1; 5 x 2,3,4,5; 4 x 6; 3 x 7,8,9; 4 x 0
Neutral: 1x 15 mm, 1x 30 mm + brush, tweezers, key

Type case TH4E-11-TC content

Letters: 1x P, 1x N, 3x letters empty
Numbers: 6 x 1; 5 x 2,3,4,5; 4 x 6; 3 x 7,8,9; 4 x 0
Neutral: 1x 15 mm, 1x 30 mm + brush, tweezers, key

Ultra Clean Kit TH 6-10-EL-7

Removes contaminants from inside hose assemblies

- Cleaning size -4 up to size -20 hose
- Reduces downtime and risk of hose failure
- Has a quarter-turn locking ring for easy nozzle change and projectile loading
- Durable brass and aluminium internals, strong plastic handle, and anodized aluminium firing head and locking ring



Primary Applications

Workshops and mobile service vehicles

Restrictions

5 micron filter and regulator with gauge are strongly suggested

Technical / Order Data

Ultra Clean Kit TH 6-10-EL-7 with case, launcher in size -20, nozzles in size -4, -6, -8, -10, -12, -16 and -20 (1 each)

Air pressure	min. 0.55 MPa max. 0.75 MPa
Air connection	1/2" I.D. air hose
Dimensions	L 407 x W 134 x H 343 mm
Weight	4 kg
Part Number	TH6-10-EL-7

Nozzles and Projectiles for Ultra Clean Kit TH6-10-EL-7

Hose Size	Nozzle Part Number	Projectile Part Number
-4	TH6-10-H06	TH6-10-P10
-5	TH6-10-H08	TH6-10-P12
-6	TH6-10-H10	TH6-10-P14
-8	TH6-10-H13	TH6-10-P18
-10	TH6-10-H16	TH6-10-P22
-12	TH6-10-H19	TH6-10-P26
-16	TH6-10-H25	TH6-10-P33
-20	TH6-10-H32	TH6-10-P40

Ultra Clean Kit TH 6-10-HL-9-2

Removes contaminants from inside hose assemblies

- Cleaning size -4 up to size -32 hose
- Reduces downtime and risk of hose failure
- Full-flow quick release coupling and unique 360° rotary plug for proper air flow and non-fatigue operator use
- Aluminium, fully anodized for harsh environments and heavy use
- Unique safety release bar that locks the faceplate into a closed position for firing Ultra Clean projectiles



Primary Applications

Workshops and mobile service vehicles

Restrictions

5 micron filter and regulator with gauge are strongly suggested

Technical / Order Data

Ultra Clean Kit TH 6-10-HL-9-2 with case, launcher in size -32, nozzles in size -4, -6, -8, -10, -12, -16, -20, -24 and -32 (1 each)

Air pressure	min. 0.55 MPa max. 0.75 MPa
Air connection	1/2" I.D. air hose
Dimensions	L 407 x W 134 x H 343 mm
Weight	5 kg
Part Number	TH6-10-HL-9-2

Nozzles and Projectiles for Ultra Clean Kit TH6-10-HL-9-2

Hose Size	Nozzle Part Number	Projectile Part Number
-4	TH6-10-H06	TH6-10-P10
-5	TH6-10-H08	TH6-10-P12
-6	TH6-10-H10	TH6-10-P14
-8	TH6-10-H13	TH6-10-P18
-10	TH6-10-H16	TH6-10-P22
-12	TH6-10-H19	TH6-10-P26
-16	TH6-10-H25	TH6-10-P33
-20	TH6-10-H32	TH6-10-P40
-24	TH6-10-H38	TH6-10-P50
-32	TH6-10-H50	TH6-10-P60

Hose Assembly Test Bench TH 5-3

Pressure test bench up to 145.0 MPa

- Totally sealed test chamber
- Safety interlock – pressure automatically decreases within 1/10 sec. when the test chamber is opened
- Rapid fill and automatic air bleeding of the test piece
- Weight-compensated protection cover with safety windows
- Bio-degradable water-oil emulsion as test medium
- Simple operation



Primary Applications

Service and series production in workshops. The hose assembly test bench makes the efficient and safe final inspection of hose assemblies practical and fast. Static pressure testing of other hydraulic components is also possible.

Restrictions

This test bench is not designed for burst pressure testing. Due to the limited flexibility of large bore multispiral hoses it is not ideal for size -24 and size -32 pressure testing.

Technical / Order Data

Hose Assembly Test Bench TH 5-3 incl. HD adapter set

Test pressure	12.0 - 145.0 MPa	
Drive	intensifier	
Compressed air rating	0.7 MPa, 20 NI/min	
Pressure regulator	manual	
Test medium	water-oil emulsion	
Safety control unit	yes	
Tank capacity	100 l	
Colour	black / silver	
Dimensions	L 2210 x W 840 x H 1260 mm	
Weight	empty	210 kg
	with medium	310 kg
Accessories	filter 100 µm, air service unit	
Part Number	TH5-3	

Hose Assembly Test Bench TH 5-3 with result recording unit

Part Number TH5-3-BM

HD adapter set

Part Number 405.906

Corrosion protection, 10 l

Part Number H899770

Parker's Motion & Control Technologies

At Parker, we're guided by a relentless drive to help our customers become more productive and achieve higher levels of profitability by engineering the best systems for their requirements. It means looking at customer applications from many angles to find new ways to create value. Whatever the motion and control technology need, Parker has the experience, breadth of product and global reach to consistently deliver. No company knows more about motion and control technology than Parker. For further information call free on 00800 27 27 5374.



AEROSPACE

Key Markets

- Aircraft engines
- Business & general aviation
- Commercial transports
- Land-based weapons systems
- Military aircraft
- Missiles & launch vehicles
- Regional transports
- Unmanned aerial vehicles

Key Products

- Flight control systems & components
- Fluid conveyance systems
- Fluid metering delivery & atomization devices
- Fuel systems & components
- Hydraulic systems & components
- Inert nitrogen generating systems
- Pneumatic systems & components
- Wheels & brakes



HYDRAULICS

Key Markets

- Aerospace
- Aerial lift
- Agriculture
- Construction machinery
- Forestry
- Industrial machinery
- Mining
- Oil & gas
- Power generation & energy
- Truck hydraulics

Key Products

- Diagnostic equipment
- Hydraulic cylinders & accumulators
- Hydraulic motors & pumps
- Hydraulic systems
- Hydraulic valves & controls
- Power take-offs
- Rubber & thermoplastic hose & couplings
- Tube fittings & adapters
- Quick disconnects



CLIMATE CONTROL

Key Markets

- Agriculture
- Air conditioning
- Food, beverage & dairy
- Life sciences & medical
- Precision cooling
- Processing
- Transportation

Key Products

- CO² controls
- Electronic controllers
- Filter driers
- Hand shut-off valves
- Hose & fittings
- Pressure regulating valves
- Refrigerant distributors
- Safety relief valves
- Solenoid valves
- Thermostatic expansion valves



PNEUMATICS

Key Markets

- Aerospace
- Conveyor & material handling
- Factory automation
- Life science & medical
- Machine tools
- Packaging machinery
- Transportation & automotive

Key Products

- Air preparation
- Brass fittings & valves
- Manifolds
- Pneumatic accessories
- Pneumatic actuators & grippers
- Pneumatic valves & controls
- Quick disconnects
- Rotary actuators
- Rubber & thermoplastic hose & couplings
- Structural extrusions
- Thermoplastic tubing & fittings
- Vacuum generators, cups & sensors





PROCESS CONTROL

Key Markets

- Chemical & refining
- Food, beverage & dairy
- Medical & dental
- Microelectronics
- Oil & gas
- Power generation

Key Products

- Analytical sample conditioning products & systems
- Fluoropolymer chemical delivery fittings, valves & pumps
- High purity gas delivery fittings, valves & regulators
- Instrumentation fittings, valves & regulators
- Medium pressure fittings & valves
- Process control manifolds



ELECTROMECHANICAL

Key Markets

- Aerospace
- Factory automation
- Life science & medical
- Machine tools
- Packaging machinery
- Paper machinery
- Plastics machinery & converting
- Primary metals
- Semiconductor & electronics
- Textile
- Wire & cable

Key Products

- AC/DC drives & systems
- Electric actuators
- Controllers
- Gantry robots
- Gearheads
- Human machine interfaces
- Industrial PCs
- Inverters
- Linear motors, slides and stages
- Precision stages
- Stepper motors
- Servo motors, drives & controls
- Structural extrusions



FILTRATION

Key Markets

- Food & beverage
- Industrial machinery
- Life sciences
- Marine
- Mobile equipment
- Oil & gas
- Power generation
- Process
- Transportation

Key Products

- Analytical gas generators
- Compressed air & gas filters
- Condition monitoring
- Engine air, fuel & oil filtration & systems
- Hydraulic, lubrication & coolant filters
- Process, chemical, water & microfiltration filters
- Nitrogen, hydrogen & zero air generators



SEALING & SHIELDING

Key Markets

- Aerospace
- Chemical processing
- Consumer
- Energy, oil & gas
- Fluid power
- General industrial
- Information technology
- Life sciences
- Military
- Semiconductor
- Telecommunications
- Transportation

Key Products

- Dynamic seals
- Elastomeric o-rings
- EMI shielding
- Extruded & precision-cut, fabricated elastomeric seals
- Homogeneous & inserted elastomeric shapes
- High temperature metal seals
- Metal & plastic retained composite seals
- Thermal management



FLUID & GAS HANDLING

Key Markets

- Aerospace
- Agriculture
- Bulk chemical handling
- Construction machinery
- Food & beverage
- Fuel & gas delivery
- Industrial machinery
- Mobile
- Oil & gas
- Transportation
- Welding

Key Products

- Brass fittings & valves
- Diagnostic equipment
- Fluid conveyance systems
- Industrial hose
- PTFE & PFA hose, tubing & plastic fittings
- Rubber & thermoplastic hose & couplings
- Tube fittings & adapters
- Quick disconnects

ENGINEERING YOUR SUCCESS.

Parker Worldwide

Europe, Middle East, Africa

AE – United Arab Emirates,

Dubai

Tel: +971 4 8127100

parker.me@parker.com

AT – Austria, Wiener Neustadt

Tel: +43 (0)2622 23501-0

parker.austria@parker.com

AT – Eastern Europe, Wiener Neustadt

Tel: +43 (0)2622 23501 900

parker.easteurope@parker.com

AZ – Azerbaijan, Baku

Tel: +994 50 2233 458

parker.azerbaijan@parker.com

BE/LU – Belgium, Nivelles

Tel: +32 (0)67 280 900

parker.belgium@parker.com

BG – Bulgaria, Sofia

Tel: +359 2 980 1344

parker.bulgaria@parker.com

BY – Belarus, Minsk

Tel: +375 17 209 9399

parker.belarus@parker.com

CH – Switzerland, Etoy

Tel: +41 (0)21 821 87 00

parker.switzerland@parker.com

CZ – Czech Republic, Klecany

Tel: +420 284 083 111

parker.czechrepublic@parker.com

DE – Germany, Kaarst

Tel: +49 (0)2131 4016 0

parker.germany@parker.com

DK – Denmark, Ballerup

Tel: +45 43 56 04 00

parker.denmark@parker.com

ES – Spain, Madrid

Tel: +34 902 330 001

parker.spain@parker.com

FI – Finland, Vantaa

Tel: +358 (0)20 753 2500

parker.finland@parker.com

FR – France, Contamine s/Arve

Tel: +33 (0)4 50 25 80 25

parker.france@parker.com

GR – Greece, Athens

Tel: +30 210 933 6450

parker.greece@parker.com

HU – Hungary, Budaörs

Tel: +36 23 885 470

parker.hungary@parker.com

IE – Ireland, Dublin

Tel: +353 (0)1 466 6370

parker.ireland@parker.com

IT – Italy, Corsico (MI)

Tel: +39 02 45 19 21

parker.italy@parker.com

KZ – Kazakhstan, Almaty

Tel: +7 7273 561 000

parker.easteurope@parker.com

NL – The Netherlands, Oldenzaal

Tel: +31 (0)541 585 000

parker.nl@parker.com

NO – Norway, Asker

Tel: +47 66 75 34 00

parker.norway@parker.com

PL – Poland, Warsaw

Tel: +48 (0)22 573 24 00

parker.poland@parker.com

PT – Portugal, Leca da Palmeira

Tel: +351 22 999 7360

parker.portugal@parker.com

RO – Romania, Bucharest

Tel: +40 21 252 1382

parker.romania@parker.com

RU – Russia, Moscow

Tel: +7 495 645-2156

parker.russia@parker.com

SE – Sweden, Spånga

Tel: +46 (0)8 59 79 50 00

parker.sweden@parker.com

SK – Slovakia, Banská Bystrica

Tel: +421 484 162 252

parker.slovakia@parker.com

SL – Slovenia, Novo Mesto

Tel: +386 7 337 6650

parker.slovenia@parker.com

TR – Turkey, Istanbul

Tel: +90 216 4997081

parker.turkey@parker.com

UA – Ukraine, Kiev

Tel: +380 44 494 2731

parker.ukraine@parker.com

UK – United Kingdom, Warwick

Tel: +44 (0)1926 317 878

parker.uk@parker.com

ZA – South Africa, Kempton Park

Tel: +27 (0)11 961 0700

parker.southafrica@parker.com

North America

CA – Canada, Milton, Ontario

Tel: +1 905 693 3000

US – USA, Cleveland

Tel: +1 216 896 3000

Asia Pacific

AU – Australia, Castle Hill

Tel: +61 (0)2-9634 7777

CN – China, Shanghai

Tel: +86 21 2899 5000

HK – Hong Kong

Tel: +852 2428 8008

IN – India, Mumbai

Tel: +91 22 6513 7081-85

JP – Japan, Tokyo

Tel: +81 (0)3 6408 3901

KR – South Korea, Seoul

Tel: +82 2 559 0400

MY – Malaysia, Shah Alam

Tel: +60 3 7849 0800

NZ – New Zealand, Mt Wellington

Tel: +64 9 574 1744

SG – Singapore

Tel: +65 6887 6300

TH – Thailand, Bangkok

Tel: +662 186 7000-99

TW – Taiwan, Taipei

Tel: +886 2 2298 8987

South America

AR – Argentina, Buenos Aires

Tel: +54 3327 44 4129

BR – Brazil, Sao Jose dos Campos

Tel: +55 800 727 5374

CL – Chile, Santiago

Tel: +56 2 623 1216

MX – Mexico, Toluca

Tel: +52 72 2275 4200

European Product Information Centre

Free phone: 00 800 27 27 5374

(from AT, BE, CH, CZ, DE, DK, EE, ES, FI, FR, IE, IL, IS, IT, LU, MT, NL, NO, PL, PT, RU, SE, SK, UK, ZA)

Parker Hannifin Ltd.

Tachbrook Park Drive

Tachbrook Park,

Warwick, CV34 6TU

United Kingdom

Tel.: +44 (0) 1926 317 878

Fax: +44 (0) 1926 317 855

parker.uk@parker.com

www.parker.com

